

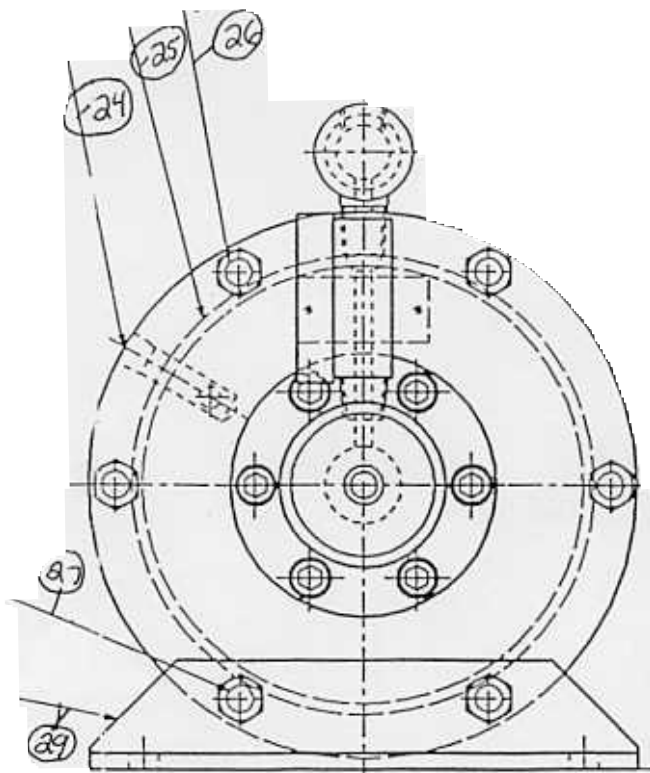

# APD50-112

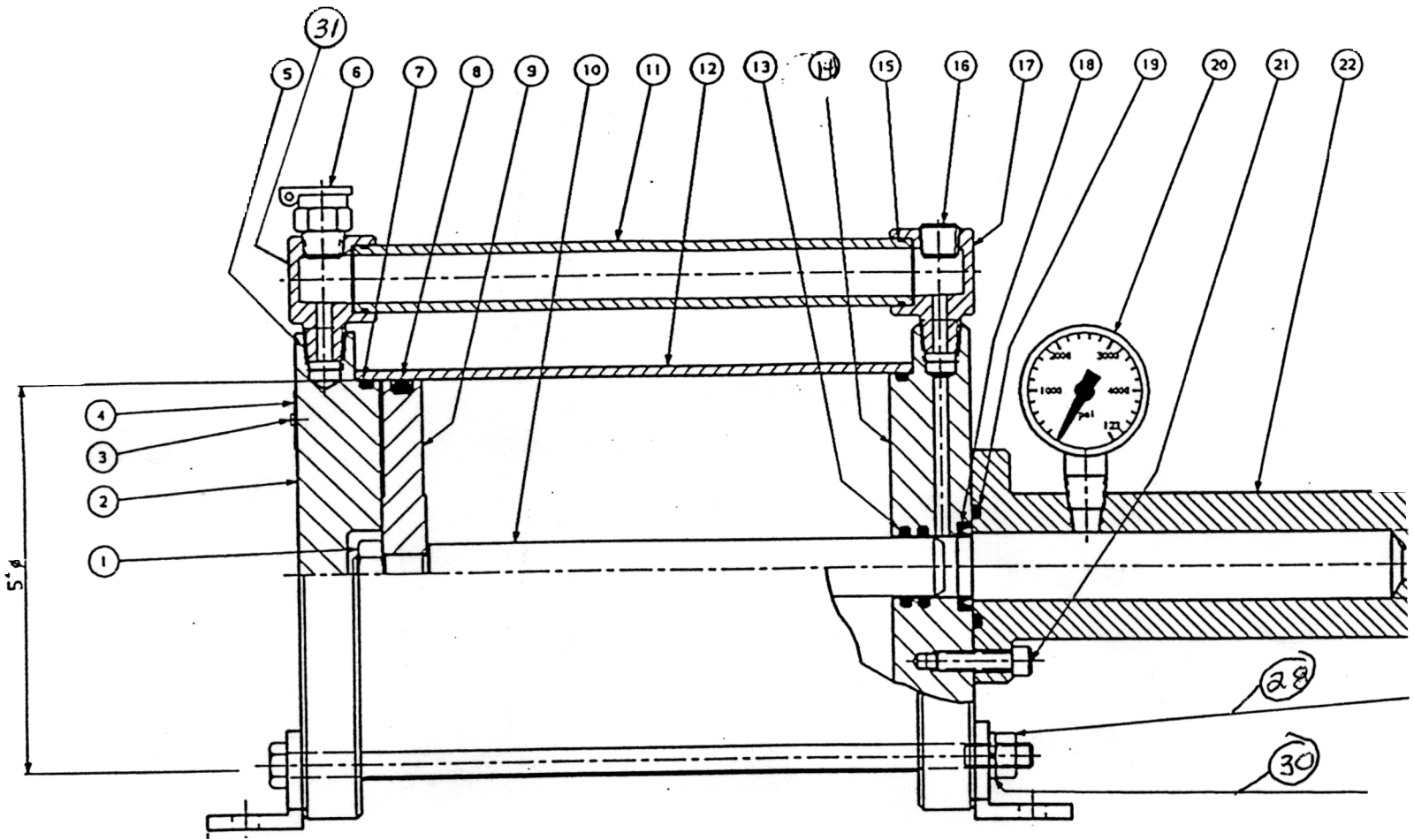

31	APD50-301	A18465	CAP, OIL RESERVOIR	1	M
30	06-2111	N/A	WASHER, SPRING LOCK, 5/16"	6	P
29	APD50-126	B11057	FOOT	2	M
28	06-0311	N/A	NUT, HEX, 5/16-18, STL.	6	P
27	APD40-133	N/A	HEX HEAD SCREW, (LONG) 5/16-18 UNC X 9 1/2" LONG	2	P
26	APD40-132	N/A	HEX HEAD SCREW, (SHORT) 5/16-18 UNC X 9" LONG	4	P
25	APD40-111	B11065	CAUTION TAG	2	P
24	229-Z	N/A	PLUG, PLASTIC, FOR 1/8-27 NPT INTERNAL "NIAGARA" #229-Z	2	P
23	181	N/A	PLUG, PLASTIC, FOR 1/4-18 NPT INTERNAL "NIAGARA" #181	2	P
22	APD50-122	B11053	CYLINDER, OIL	1	M
21	00-1324	N/A	SHCS, 5/16-18 X 1" LONG	6	P
20	APD50-255		PRESSURE GAGE, 0-5000 psi, 1-1/2" Dia., McDANIEL CONTROL TYPE R	1	P
19	APD50-130	N/A	O-RING, 1 1/4 X 1 1/2 X 1/8, #ACO-568-218 70 DUROMETER, BUNA N	1	P
18	APD50-13i	N/A	U-CUP SEAL, 3/4 X 1 1/8 X 3/16, GARLOCK MODEL 92, #17149-1259	1	P
17	APD50-139	A11059	CAP, OIL RESERVOIR	2	M
16	PTH400-182	N/A	1/4-18 NPT PIPE PLUG, HOLLOW HEX, STEEL, "PARKER" #01HP-4	1	P
15	APD50-119	N/A	O-RING, 3/4 X 7/8 X 1/16, #ACO-568-018 70 DUROMETER, BUNA N	2	P
14	APD50-121	C11052	END CAP (RIGHT)	1	M
13	APD50-129	N/A	O-RING, 3/4 X 1 X 1/8, #ACO-568-210 70 DUROMETER, BUNA N	2	P
12	APD50-125	B11056	CYLINDER, AIR	1	M
11	APD50-107	B11058	TUBE, OIL RESERVOIR	1	M
1	PART NO.	DWG. NO.	DESCRIPTION	QTY.	PUR / MFR

10	APD50-124	B11055	PUSH ROD	1	M
9	APD50-123	A11054	PISTON, AIR	1	
8	APD50-128	N/A	O-RING, 4 5/8 X 5 X 3/16, #ACO-568-350 70 DUROMETER, BUNA N	1	
7	APD50-127	N/A	O-RING, 4 3/4 X 5 X 1/8, #ACO-568-248 70 DUROMETER, BUNA N	2	
6	APD40-118	N/A	OIL COVER, "GITS" #211	1	
5	APD50-138	N/A	NIPPLE, 1/4-18 NPT X 7/8" LG.	2	
4	KA9981	A9981	SERIAL NO. TAG (SMALL)	1	
3	07-0230	N/A	DRIVE SCREW, #2 TYPE U X 1/4"	2	
2	APD50-120	C11051	END CAP (LEFT)	1	
1	06-0338	N/A	NUT, HEX JAM, 1/2-13, STL.	1	
ITEM	PART NO.	DWG. NO.	DESCRIPTION	QTY.	

V. CC>M. APD50

 MINNEAPOLIS	TOLERANCES UNLESS NOTED INCHES FRACTIONAL # 1/32 DECIMAL .XX # .010 .XXX # .005 .XXXX # .0005 ANGLES # 1°		TOOL NAME <b>5" AIR/OIL INTENSIFIER</b>	MODEL OF TOOL <b>APD50</b>
			TITLE <b>5" AIR OVER OIL INTENSIFIER</b>	DWG SIZE <b>D</b>
	DESIGNED <b>BERNSTEIN</b>			CUSTOMER <b>KURT</b>
	DETAILED <b>S. KAARTO</b>	<b>09/21/89</b>		CUST. PART NO. <b>APD50</b>
	CHECKED 		DESCRIPTION OR MATERIAL <b>ASSEMBLY</b>	TOOL NO. -
APPROVED 			SCALE <b>1:1</b>	

# APD50-112

"O"-RING KIT P/N APD50-112-KIT \$17.50 PAGE 2 OF 2