

KURT

AngLock DoubleLock

KURT
AngLock DoubleLock
Vise

Model:

DL640

DL430

CT640

CT430

Installation & Operation Guide



P/N DL640-95, REV C

KURT INDUSTRIAL PRODUCTS

OVERVIEW OF "640, 430" VISES

The new DoubleLock vises from Kurt include improvements that simplify its operations. Please read this entire instruction manual to fully understand the new features of the DoubleLock vise. You will find modifications have been made that are different from the past DoubleLocks.

Kurt's new DoubleLock has a design that fits current user needs and meets their expectations of a simple, functional vise. The new DL640, DL430, CT640, and CT430 maintains the 3", and 4" opening, same bed height with the DL430 and DL640, and same accuracy and has superior features over past Kurt DoubleLock style vises. Listed are the re-designed features of the new DoubleLock vise. Please refer to the page listed on index for setup instructions.

1. **Clutch design-** The new clutch has a recoil spring attached to the clutch. It's designed to return the clutch back into the correct position automatically. It resets into the correct position every time the vise jaws are opened. No more timing problems ever!
2. **New Holding Block-** The function of the holding block is to give the end user the adjustment features to clamp dissimilar size parts and provides front or back part spring loaded pre-clamping. The new holding block is completely self-adjusting that includes a double pre-load. This means the user may clamp one part first, front or back station before loading the second part. No need to adjust for dissimilar parts. Also included is a pre-load range adjustment nut that will give the user the option to choose how much pre-load range they need. (.010 min to .150" max) When setting to minimum range, this will reduce the amount of handle turns needed when opening or closing the Vise. **PLEASE NOTE:** This vise has been assembled to factory settings and no further adjustments are required. The holding block pre-load and pre-load adjustment nut are new features of this products design and allows adjustment for a specific setup. Please see "Holding Block Pre-Load" and "Pre-Load range adjustment nut" setup sections in this guide.
3. **New Overall length-** DL640 is 22.5"(21.5" with optional internal hex), and 18.5" (17.5" with internal hex) on the DL430.

4. **New Chip Guard system-** The center clamping area is fully covered 100% of the time. Note: The stationary chip guard may need to be removed when the vise is used with the optional conversion kit. See conversion kit assemble section.
5. **New Locating hole patterns-** The clamp down mounting holes that will fit a standard 2" grid pattern found in sub-plates available through several industrial suppliers. The base includes four precision 5/8" holes in the bottom for accurate re-location. Also available are two 16mm holes that will fit a 100mm and/or 200mm grid patterns found in metric sub-plates. (See locating and mounting hole sketch for reference). The use of Sine Keys would also provide mounting the Vise to machine tables with key slots if needed.
6. **New Stationary Jaw-** The DoubleLock vise has a precision locator for accurate repeatability. This gives the Stationary Jaws exact relocation when used with interchangeable Stationary Jaw setups or re-setup from a convertible model.
7. **Convertible models-** When the DL640 or DL430 is needed for a single large part clamping, the maximum opening is 10.69" to a minimum of 2.69", and 8.20" to 2.1" on the DL430. This is a continuous travel opening.

Kurt offers quick change one-sided Aluminum carvable Moveable Jaws for conversion into a carvable vise. Optional internal hex is also available. (Contact factory for information and costs).

These important features and functions make Kurt's new DoubleLock an accurate, durable, affordable "user friendly" vise. Combined with the industries only ten (10) year warranty. The Kurt DoubleLock vises fills all your CNC WorkHolding needs.

DOUBLE LOCK INSTALLATION AND MOUNTING INSTRUCTIONS

INSTALLATION

The Kurt DoubleLock Vise offers two clamping stations. This vise is ideal for clamping parts of the same size or dissimilar size, and can perform first and secondary operations simultaneously. It is packaged to prevent any damage to its components. Please inspect the vise carefully for any shipping damage and, if necessary report it to your carrier.

After inspection, follow these steps to install your DoubleLock Vise:

1. Position the vise on your machine table, pallet or sub-plate using the Precision bored holes located on the bottom of the vise for alignment. See figure 2 on page 4 for locating hole patterns.
2. A couple of options to mount the vise in place. One option is to use external clamps on the clamp groove on each side of the vise. **NOTE:** To reduce any possible deflection while clamping parts, mount external clamps on each side towards the center of the vise in the clamp grooves.

A **preferred** option would be to use the eight cap screw holes through the vise bed. To gain access to the holes, open both stations to the full opening. Remove the Jaw Plates mounted to the center Stationary Jaw and two Moveable Jaws sets. See figure 1, page 4 for mounting hole pattern. **Note:** The four mounting holes toward the center Stationary is required when using this mounting option. The four mounting holes under Moveable Jaws are an addition to mounting with this setup.

If desired both mounting options may be used.

FIGURE 1

PRIMARY MOUNTING HOLE PATTERN (TOP VIEW)

(SEE LOCATING HOLE PATTERN (BOTTOM VIEW) FOR OPTIONAL SECONDARY MOUNTING HOLE PATTERN)

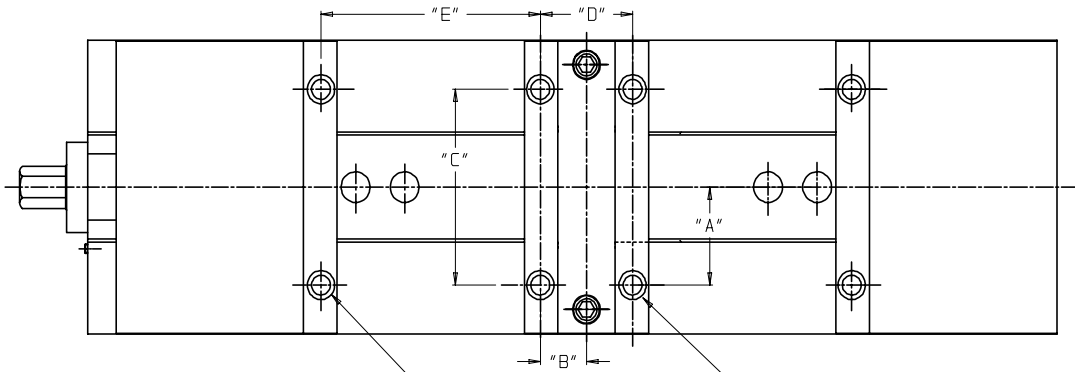

ADDITION TO REQUIRED MOUNTING OPTION,
4 X DR & C'BORED FOR "F" SHCS

REQUIRED WHEN USING THIS MOUNTING OPTION,
4 X DR & C'BORED FOR "F" SHCS

MODEL	"A" DIM (4X)	"B" (2X)	"C" (4X)	"D" (4X)	"E" (4X)	"F"
DL640	2.000	1.000	4.000	2.000	4.750	3/8" SHCS
DL430	1.500	.781	3.000	1.562	3.625	5/16" SHCS
-						

LOCATING HOLE PATTERN (BOTTOM VIEW)

** (OPTIONAL SECONDARY MOUNTING HOLE PATTERN)

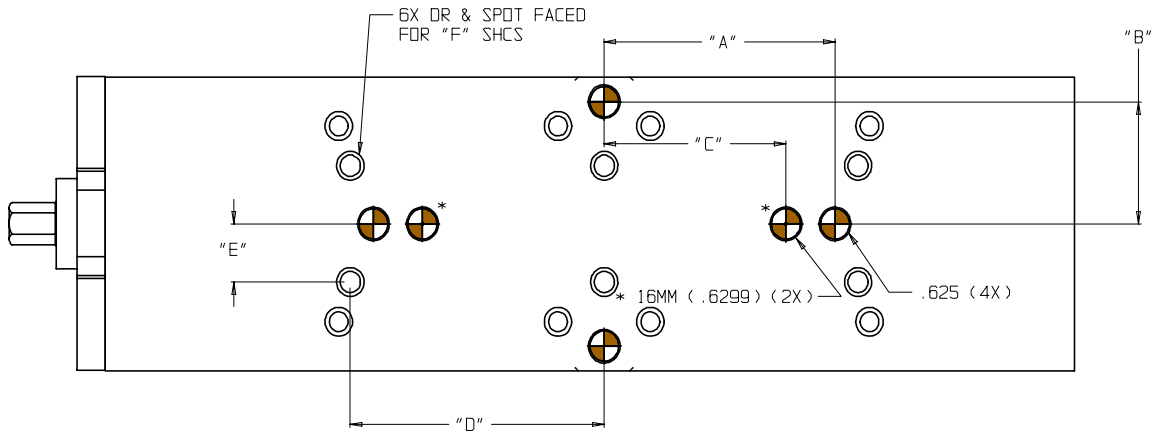

MODEL	"A" DIM (2X)	"B" (2X)	"C" (2X)	** "D" (4X)	** "E" (6X)	"F"
DL640	5.000	2.500	100MM (3.937)	5.500	1.188	3/8" SHCS
DL430	5.000	1.500	100MM (3.937)	5.500	.813	5/16" SHCS
-						

FIGURE 2

Holding Block Pre-load setup

***PRE-LOAD PARTS.**

(* Is defined as ability to clamp one part first with limited pressure before second part is installed.)

Caution: Pre-Load places only enough spring pressure to hold one part and are not intended to clamp part for machining. Both stations must be clamped to achieve clamping pressures.

NOTE 1: In all jaw settings, unless both parts are the same size, the **Widest** part must always be mounted in the Rear Jaw Set. See figure 3 page 6.

NOTE 2: Same size part, Pre-load must be setup to clamp front part.

Horizontal vise position (reference sketches on page #6)

1. Open both Moveable Jaws sets to accept part being clamped.
2. Place one part into each station and close.
3. Open only enough to release pressure from each parts.
4. Remove the part that is planned to be pre-loaded. (**Vertical vise position see caution below**)
5. Leaving the opposite part in the vise, begin to close allowing the Holding block to slide 3/16" minimum. See figure 4 page 6.
6. Begin to open and both Movables will open.
7. Remove all parts in the vise.
8. Your Pre-load is now set.
9. Place part to be Pre-loaded in and begin to close until part is clamped. Install opposite part and clamp.

Vertical vise position

Caution: In this position, the horizontal vise position setup is used but we recommend to always setup with the pre-load in the top station. The Stationary Jaw is a fixed stop where the bottom Moveable Jaw will have movement and part could appear to be pre-loaded and part could move causing personal injury. Please use caution at step #4.

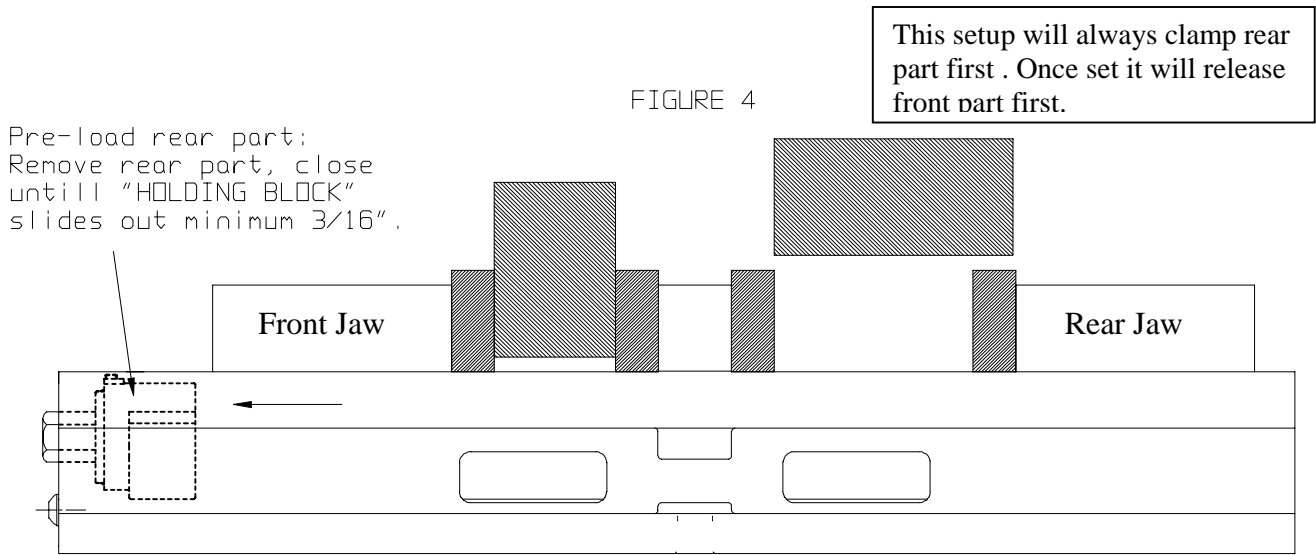
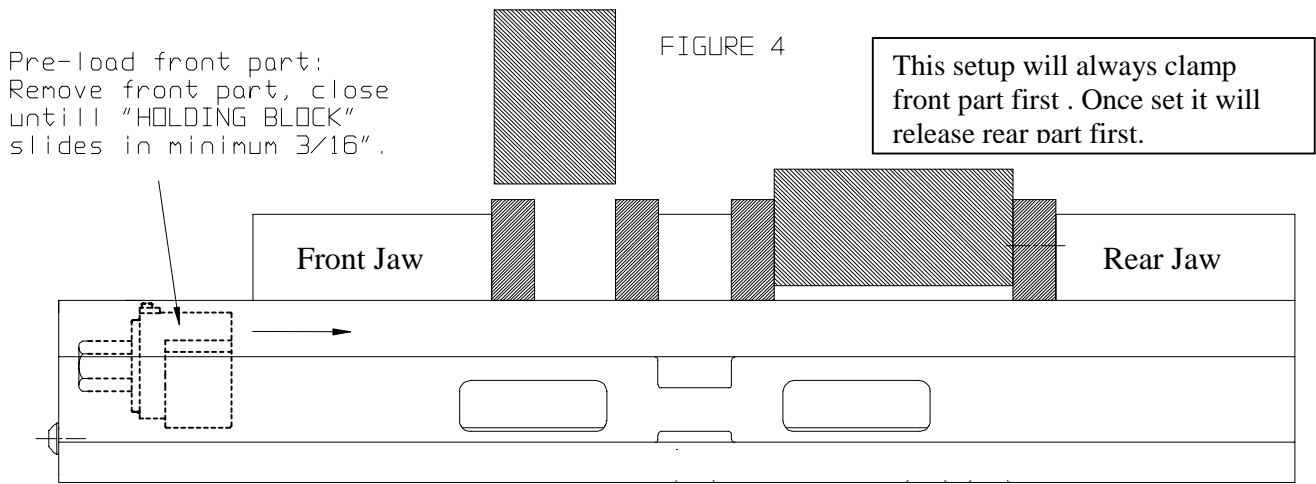
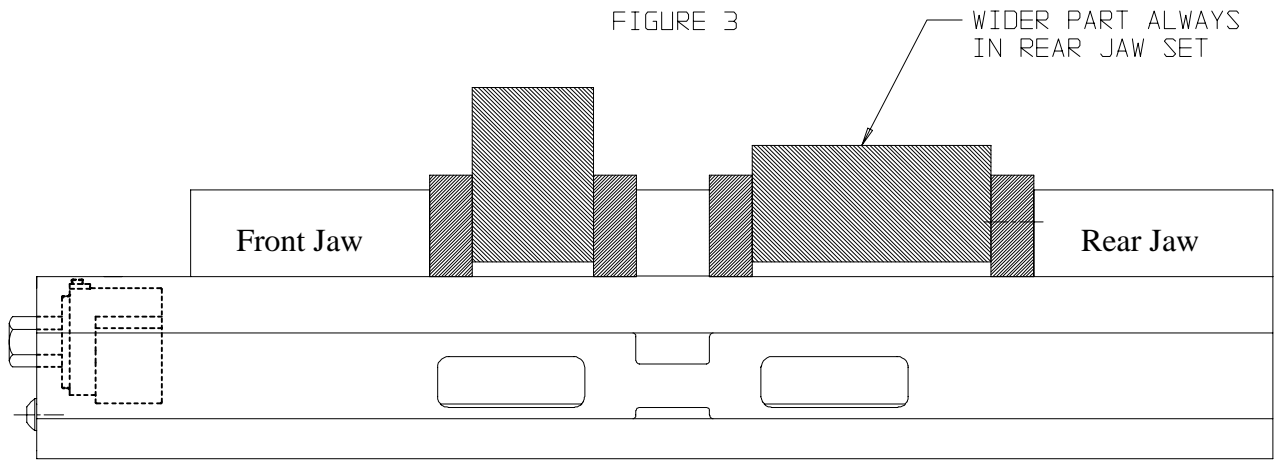

Pre-Load range Adjustment Nut

Refer to sketch below for direction of adjustment

To remove Pre-Load range (Reducing the amount of turns of the handle when clamping or unclamping parts).

1. Loosen but do not remove the (socket head set screw) on top of Holding Block.
2. With the use of a spanner wrench, begin to turn the Adjustment Nut clockwise. Each full turn will reduce Pre-Load amount by approximately .04. NOTE: Maximum reduction is .100/.150 or approximately 3-3/4 turns of the Nut. NOTE: If adjustment Nut turns to a complete stop before the 3-3/4 turns, maximum reduction range is complete.
3. Turn counterclockwise Aligning the first slot on the Adjustment Nut with the SHSS and tighten.

To add Pre-Load range (Increase the amount of turns of the handle)

1. Loosen but do not remove the SHSS on top of the Holding Block.
2. With a spanner wrench turn the adjustment nut counter clockwise until threads on the Adjustment Nut begin to show.
3. Align the slot on the Adjustment Nut with the SHSS and tighten.

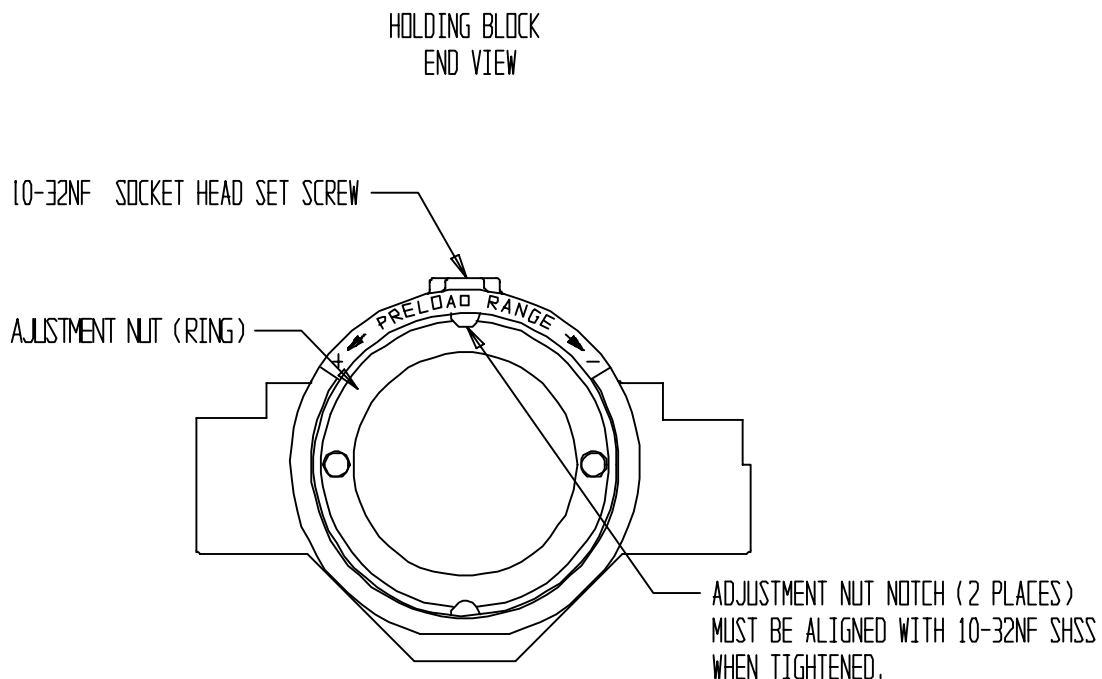

Conversion Kit Assemble - DL640, DLM640 / DL430, DLM430

Refer to Conversion Kit Sketch on this page for setup preference.

CAUTION

USE CAUTION WHEN HANDLING CHIP GUARD MATERIAL. EDGES AND CORNERS ARE SHARP AND MAY CAUSE PERSONAL INJURY IF NOT HANDLED PROPERLY.

1. Before beginning setup, clean the backside of the Rear Moveable Jaw set and the Body surface opposite the handle where Conversion Plate will be mounted.
2. Remove Stationary Jaw. Note: Stationary Jaws widths are fitted to each body and are "letter" stamped on the side of the Stationary Jaw and in the Body keyway. When reinstalling the letter stamped must match the body for proper fit.
3. Mount the Conversion Plate to the Body using the provided Socket Head Cap Screws (SHCS) and tighten.
4. Open the vise completely turning the screw counter clockwise until the back Moveable Jaw set is at maximum travel.
5. Install SHSS and tighten to the Moveable Jaw set.
6. Depending on your setup, custom cut Chip Guard maybe required. Provided with Conversion Kit is (2) standard length Chip Guard material that maybe used. Contact factory for replacement or additional Chip Guard material. Note Maximum opening and closing.

Examples of some conversion setups. All dimensions are referenced in inch.

NOTE: This vise is not to be used as a self-centering Vise

DL640 CONVERSION OPTIONS (TOP NUMBER)
DL430 CONVERSION OPTIONS (BOTTOM NUMBER)

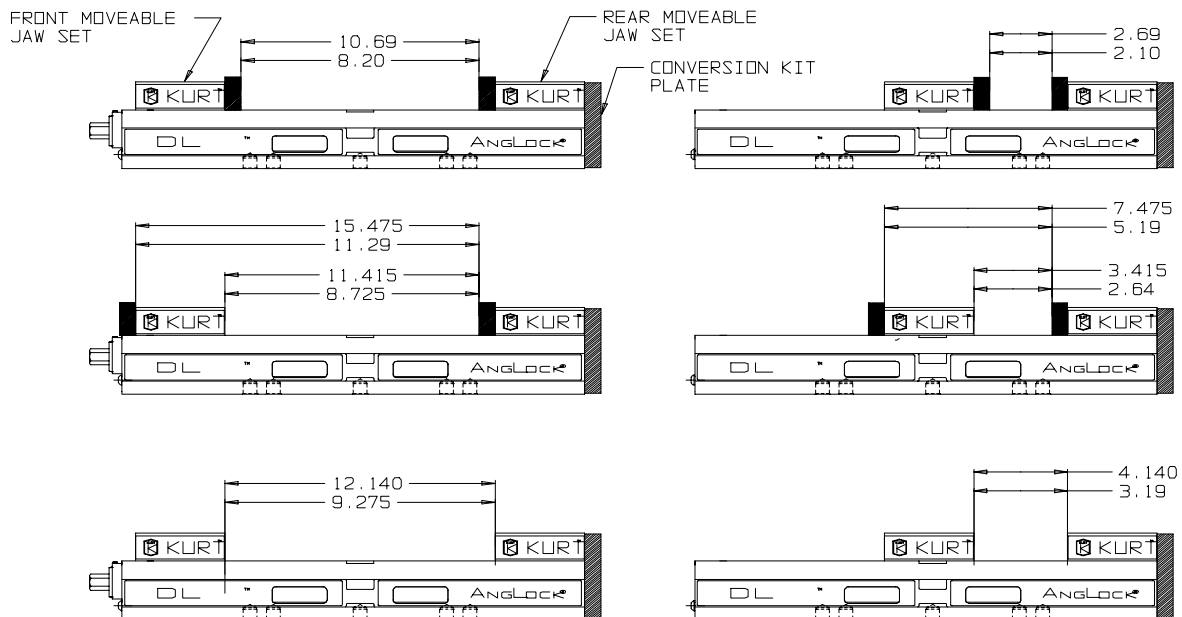

General Cleaning/Maintenance Procedure

6/18/98 rev 1

DoubleLock Model #

DL640, CT640, DL430, CT430 (metric included)

TO ASSURE PROPER USAGE AND CONTINUOUS SERVICE OF YOUR DOUBLELOCK VISE, IT IS IMPORTANT TO REGULARLY CLEAN ANY MATERIAL BUILD UP THAT MAY HAVE OCCURED. LITTLE OR NO MAINTENANCE COULD RESULT IN POOR VISE FUNCTION.

A. DISASSEMBLY INSTRUCTIONS

1. Open both Moveable jaws to the maximum openings.
2. Loosen the setscrews in the backside of both the Front and Rear Movable Jaw sets. Loosen only enough to allow Movable to pivot up off the Nut and Screw assembly. (approx. 6 turns). **NOTE:** The Chip Guards are attached to the Movables. Take care when removing Movables. **Note:** Once the Movable Jaws have been removed, there is a segment shaped as a half Ball in the cavity. Be careful not to mis-place while cleaning.
3. If maintaining more than one vise at a time, the Stationary Jaw is made specifically for the base it is in. Note stamped letters on the side of the Stationary and the inside of the hold down slot in body for re-assembly reference.
4. Remove the (2) SHCS (Socket Head Cap Screw) holding the Stationary Jaw and remove jaw.
5. Remove any remaining Chip Guards.
6. Clean disassembled parts as needed.
7. **Note:** The Nut & Screw assembly should not have to be removed if regular maintenance is done. If required to remove for additional cleaning remove the Button Head Cap Screw on Handle end of the Vise bed and slide Screw and Nut assembly out. Caution: Disassembly of the Screw and Nut assemble may result in improper function once re-assembled. Important timing is involved with the internal springs. Please contact factory for requirements.

B. ASSEMBLY INSTRUCTIONS

1. If Nut and Screw assemble was removed refer to sketch on page 10 for Nut timing. Slide Screw and Nut assemble into the Body. Install Button Head Cap Screw and tighten.

2. Before placing the (2) Movable Jaws over the Nuts make sure the segments are in the inside cavity using grease to hold them in place and for lubrication.
3. Spread a small amount of oil to the bed of the vise where the Moveable Jaws will be installed.
4. Place the Movable Jaw starting with the side with (2) holes into the center way. In a slide motion, slide Movable Jaw over the Nut allowing the Movable to drop over the Nut. **NOTE:** The 45-degree angle of the Nut should be on the flat surface of the Movable Segment.
5. Snap the Chip Guard onto the pins underneath each Moveable. Note: May need to lift up slightly to catch the pins with the Chip Guard.
6. Tighten the SHSS in the Movable until it makes contact with the Nut. Turn back approximately $\frac{1}{4}$ turn. ***IMPORTANT: THIS SHSS SHOULD NOT BE COMPLETELY TIGHT. THIS WILL ALLOW MOVEMENT OF THE MOVABLE JAWS. SEE SKETCH ON NEXT PAGE.***
7. Place the Stationary Chip Guard into place.
8. Install the Stationary Jaw and tighten in place using the (2) SHCS.
9. To seat the segments in the Movable Jaw, tighten vise with supplied handle, and then open vise until close to full opening. If needed tighten the SHSS in the back of Movable Jaws then loosen approximately $\frac{1}{4}$ turn.
10. Vise is now ready for use.

DL430

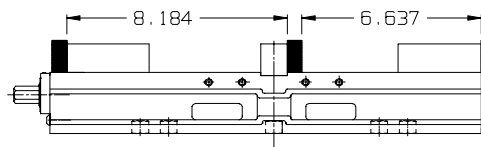
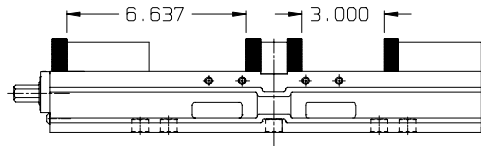
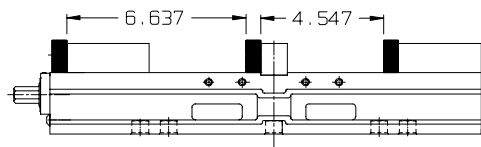
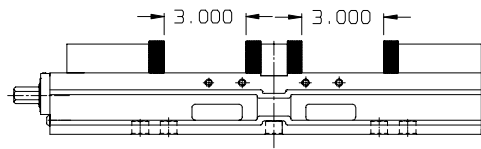
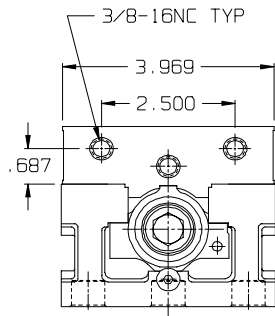
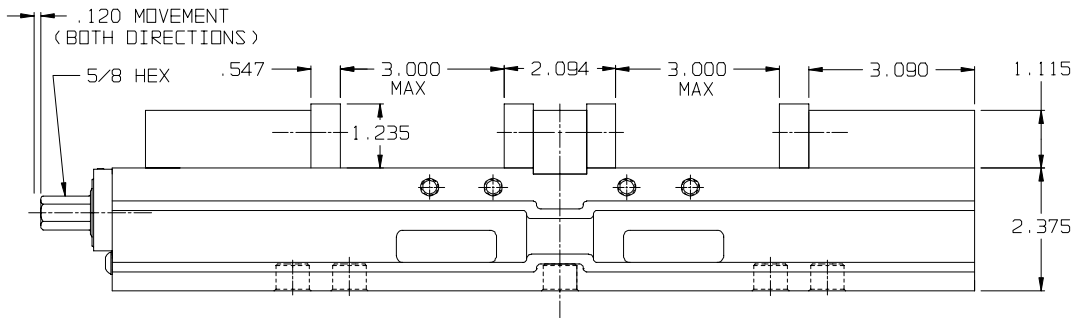
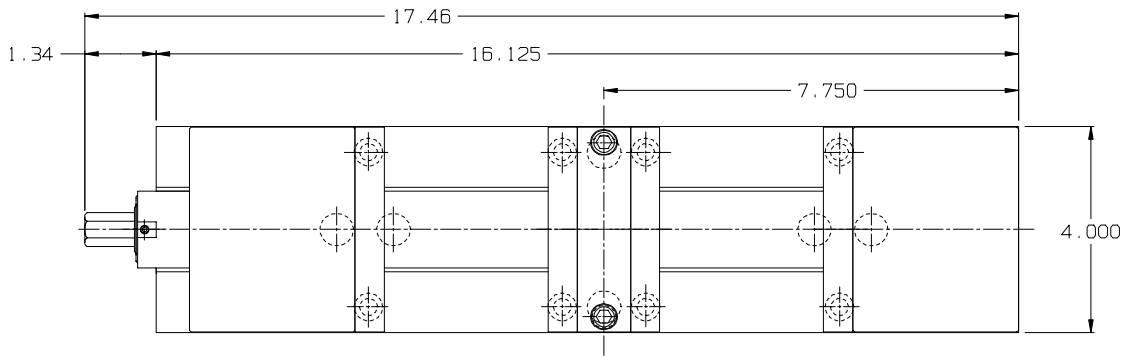

DL640

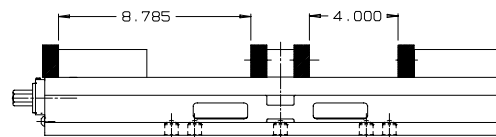
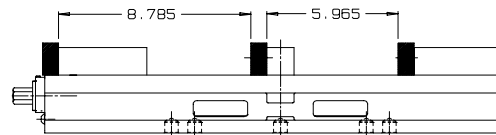
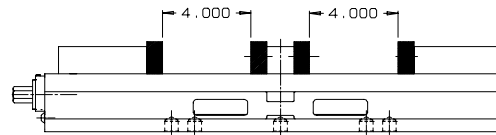
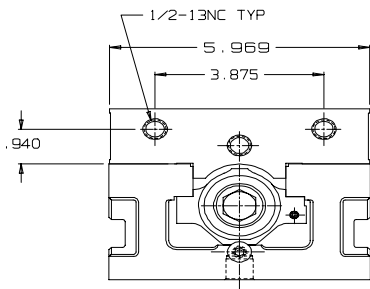
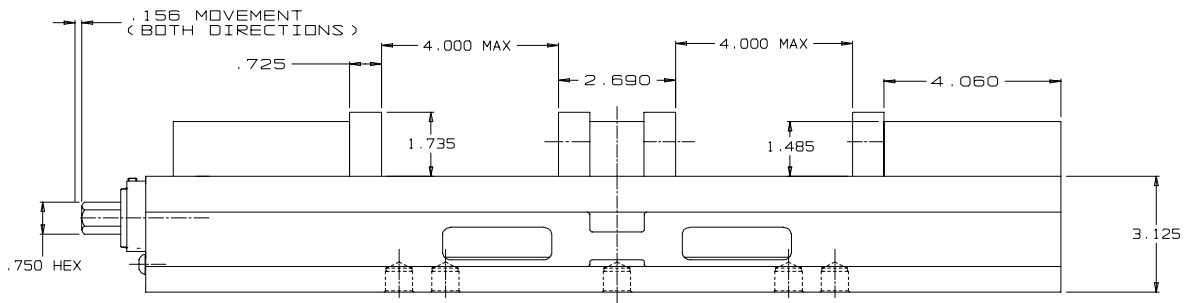
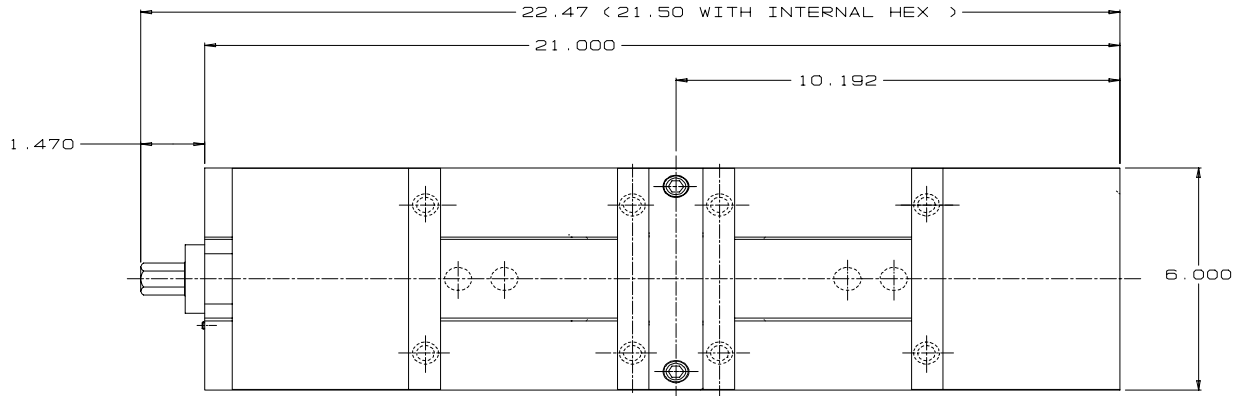

PRECAUTIONS

When using the DoubleLock Vise in production, remember the following points:

- Never use this vise as a Self Centering Vise.
- See figure #3, page 14. Never clamp parts opposite from each other.
- Always clamp directly across from each other or use a spacer to even clamping pressure points.
- Use the Handle provided or Torque Wrench with your vise. The rated clamping forces are obtained with these handles. Never use an extension or strike the handle with a hammer. This will cause damage to the thrust bearings.
- When using parallels or Step Jaws, select a size that keeps the **BOTTOM** of the clamped part at or below the top surface of the Movable Jaw. Clamping above this surface could result in Jaw lift and loss of accuracy.
- Never use a hammer, blunt object, or "cheater bar" in assisting when clamping parts in the vise. Damages to the Thrust Bearing assembly, and seals may accrue.
- Always use the handle provided, handle equivalent, or torque wrench.
- Avoid using an impact wrench. Some impact wrenches cause internal "shock" on moving components and increasing the wear significantly. If an impact wrench is used, avoid rapid movement. **Never** use the impact wrench to tighten the part. This increases the clamping forces above the product capabilities and causes stress in areas not intended to except stresses. A controllable torque impact wrench is acceptable only when clamping forces needs to be consistence. Avoid over torquing.
- Clamp parts to the lowest position possible. Part nesting at the vise base increases clamping forces and decreases the possibility of part distortion.
- Always clamp the part with the part at or near center of the vise width. Clamping a part beyond center may cause inconsistent part clamping pressures.

FIGURE 3

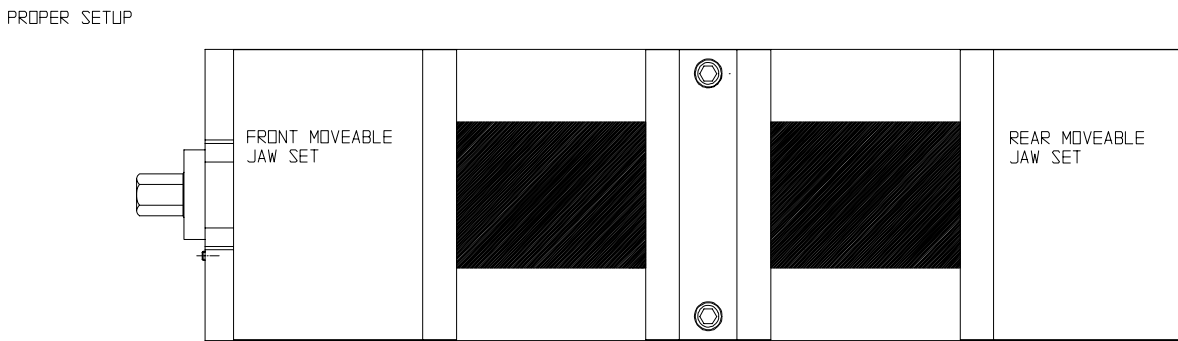
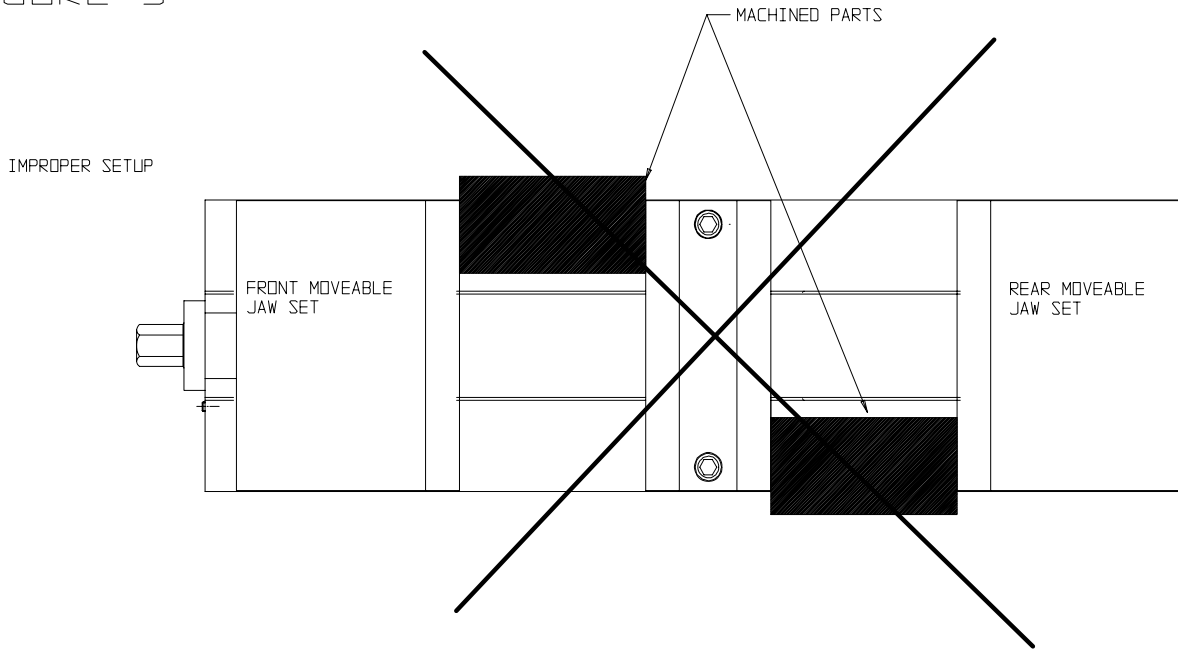

OR

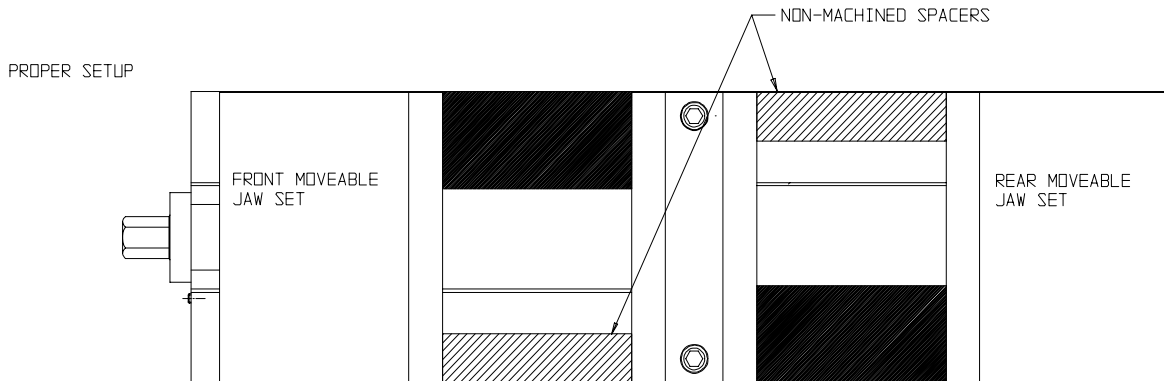

CUSTOMER SERVICE

For additional information or question about your vise, Please contact Kurt Manufacturing at 1-800-328-2565 between the hours of 7:30 a.m. and 4:30 p.m. Central Standard Time.

REPLACEMENT PARTS

Contact your Kurt Manufacturing representative for a complete list of DoubleLock replacement parts and pricing. Your representative can also provide you with a Kurt Manufacturing Product Catalog containing all products and accessories for your Workholding needs.

FACTORY CONTACT

Kurt Manufacturing Company
1325 Quincy Street N.E.
Minneapolis, MN 55413
Phone: 612-572-4424
Toll free: 1-800-328-2565
Fax: 612-623-3902
Web site: www.kurt.com

REVISION HISTORY

REVISION A
JULY 1998

COPYRIGHT 1998 KURT MANUFACTURING

THIS DOCUMENT IS CONFIDENTIAL AND IS THE PROPERTY OF KURT MANUFACTURING. IT MAY NOT BE COPIED OR REPRODUCED IN ANY WAY WITHOUT THE EXPRESS WRITTEN CONSENT OF KURT MANUFACTURING. KURT MANUFACTURING INTENDS TO AND IS MAINTAINING THE WORK AS CONFIDENTIAL INFORMATION. KURT MANUFACTURING ALSO MAY SEEK TO PROTECT THIS WORK AS AN UNPUBLISHED COPYRIGHT. IN THE EVENT OF EITHER INADVERTENT OR DELIBERATE PUBLICATION, KURT MANUFACTURING INTENDS TO ENFORCE ITS RIGHTS TO THIS WORK UNDER THE COPYRIGHT LAWS AS A PUBLISHED WORK. THOSE HAVING ACCESS TO THIS WORK MAY NOT COPY, USE OR DISCLOSE THE INFORMATION IN THIS WORK UNLESS EXPRESSLY AUTHORIZED BY KURT MANUFACTURING.

**PLEASE READ AND OBSERVE THE FOLLOWING SAFETY PRECAUTIONS
FOUND THROUGHOUT THIS MANUAL.**

CAUTION

FAILURE TO OBSERVE MAY CAUSE MINOR OR MODERATE PERSONAL INJURY OR DAMAGE TO THE EQUIPMENT.

CAUTION

USE CAUTION WHEN HANDLING CHIP GUARD MATERIAL. EDGES AND CORNERS ARE SHARP AND MAY CAUSE PERSONAL INJURY IF NOT HANDLED PROPERLY.