

PTH600A / Discontinued REPLACEMENT PARTS

LIST WAS
095 00

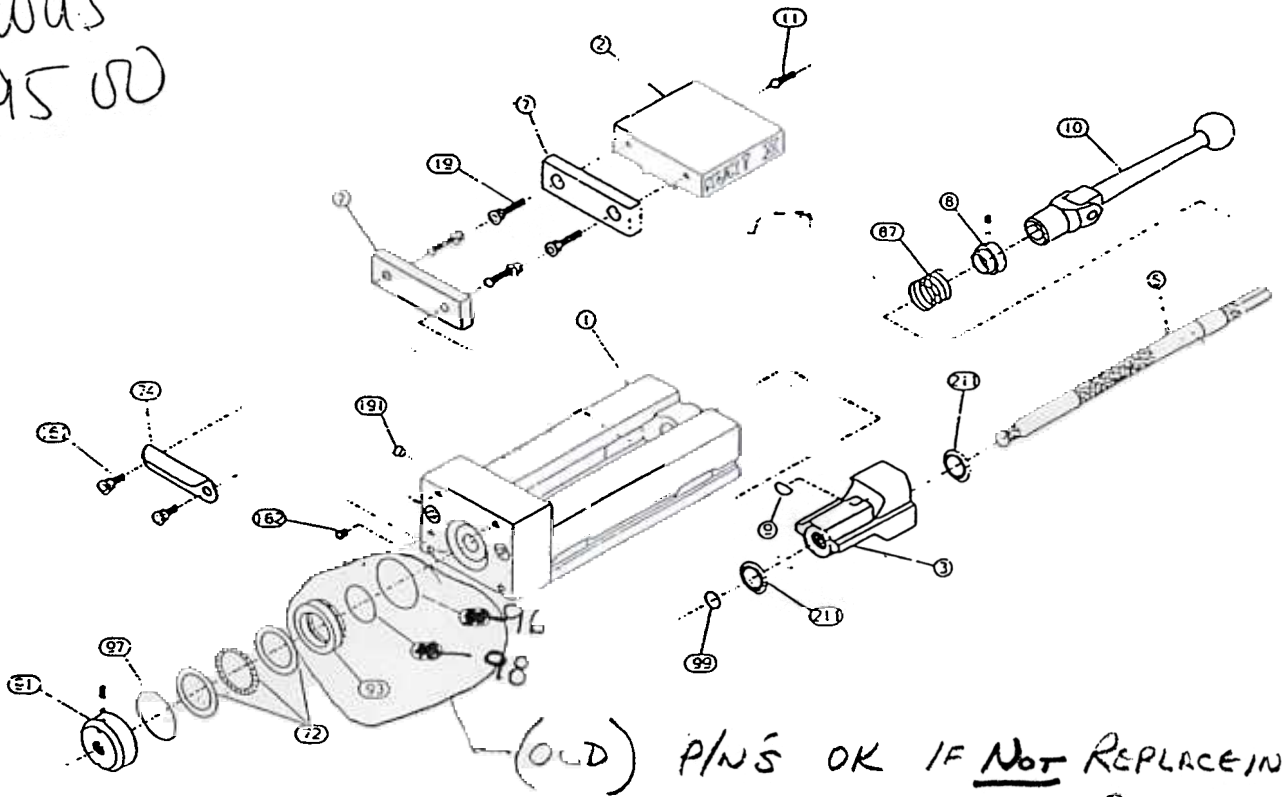

ITEM	QTY	DESCRIPTION	PART NUMBER
1	1	BODY & CYL. HSG. ASS'Y.	PTH600-1A-SA
2	1	MOVABLE JAW	PT600-2
3	1	NUT	PT600-3A
5	1	SCREW	PTH600-5
7	2	JAW PLATE	D60-7
8	1	FRONT COLLAR ASS'Y	PTH600-8-SA
9	1	SEGMENT	D60-9
10	1	HANDLE ASS'Y	D60-10-SA
11	1	SCREW. SHSS. 1/2-13 X X1-1/4	01-3335
19	4	SCREW. SHCS. 1/2-13 X 1-1/4	00-1419
41	1	THRUST BEARING	PT600-41
42	2	THRUST WASHER .060 THICK	PTH600-42
74	1	LIFTING HANDLE	PT600-74
87	1	SPRING, COMPRESSION	PTH600-87
91	1	REAR COLLAR ASS'Y	PT600-91-SA
93	1	PISTON	PTH600-93
96	1	O-RING. 2-1/2 X 2-3/4 X 1/8	PTH600-96
97	1	O-RING. 2-7/8 X 3 X 1/16	PT600-97
98	1	O-RING. 2 X 2-1/4 X 1/8	PTH400-96
99	1	O-RING. 15/16 X 1-3/16 X 1/8	PT600-99
161	2	SCREW. SHCS. 1/2-13 X 5/8	00-1412
182	1	PLUG. NPT. STEEL - 1/4NPT.	PTH400-182
191	1	PLUG. PLASTIC	181

PTH600-72 <

GRAY IN COLOR {

(OLD) P/N'S OK IF NOT REPLACING PISTON