

## **KURT MANUFACTURING - LIFETIME IRONCLAD™ WARRANTY**

All Kurt Manufacturing Company industrial workholding products and parts with the exceptions noted below, are warranted against defects in material and workmanship for the life of the product or part. (The life of the product is defined as that point in time when such item no longer functions due to normal wear and tear.) Failure to properly maintain and/or properly operate the product or part that has been worn out, abused heated ground or otherwise altered, used for a purpose other than that for which it was intended, or used in a manner inconsistent with any instructions regarding its use. The sole obligation of Kurt Manufacturing Company, Inc. (Kurt) and the purchaser's SOLE AND EXCLUSIVE REMEDY hereunder, shall be limited to the replacement or repair of any Kurt product or part (by an authorized Kurt technician) which are returned to Kurt Manufacturing Company's place of business, transportation, shipping and postal charges prepaid, and there determined by Kurt Manufacturing Company to be covered by the warranty contained herein.

**THE LIMITED WARRANTY DESCRIBED HEREIN IS MADE EXPRESSLY IN LIEU OF ANY OTHER EXPRESSED OR IMPLIED WARRANTIES, INCLUDING ANY IMPLIED WARRANTY OF MERCHANTABILITY OR FITNESS FOR A PARTICULAR PURPOSE. KURT MANUFACTURING COMPANY IS NOT RESPONSIBLE FOR THE IMPROPER USE OF ITS PRODUCTS. KURT SHALL NOT BE LIABLE FOR ANY DIRECT, INDIRECT, INCIDENTAL SPECIAL OR CONSEQUENTIAL DAMAGES, INCLUDING BUT NOT LIMITED TO, LOSS OF USE, REVENUE OR PROFIT.**

**KURT ASSUMES NO LIABILITY FOR, AND MAKES NO WARRANTY REGARDING ANY PURCHASE ITEMS WHERE THE MANUFACTURER OF SUCH ITEM EXTENDS A SEPARATE WARRANTY.**



**9445 East River Road NW  
Minneapolis, MN 55433**

**Phone: 877-226-7823**

**Fax: 877-226-7828**

**E-mail: [workholding@kurt.com](mailto:workholding@kurt.com)**

**Website: [www.kurtworkholding.com](http://www.kurtworkholding.com)**

## **KURT D100 AngLock Vise Base Assembly**

**Operating Instructions Manual**



**Thank you!**

**If you have any feedback or questions,  
please contact us at  
[workholding@kurt.com](mailto:workholding@kurt.com)  
or 877-226-7823.**



## Set-up Instructions

Now that you have your new Kurt D-Series vise, it's time to set-up and begin using it. You will see that your new vise comes with a Kurt swivel handle and an instruction manual in the shipping carton. The handle is specifically designed to provide maximum torque to your vise. Your vise should be mounted to a clean flat surface. The surface and the vise must be free of any chips, dirt or debris of any kind. The mounting surface can be honed if necessary. Clean the bottom of the vise with solvent or other cleaner if needed.

To minimize vise bed deflection, clamp your Kurt vise to your machine table, pallet, or sub-plate using the built-in clamping slots provided.

Additional clamping can be used, but may not be necessary. Please be sure to exercise good judgment when securing your vise to the mounting surface. Be sure your vise is secured and will not move when applying the machine pressure.

Manual Vise Clamping Force Lbs.	
Torque Ft-Lbs	D100
20	1698
40	3300
60	4686
80	6623
100	7842
120	9970
140	11429
160	12792
180	14681
200	16163
220	18124
240	20563
260	22093
280	24077
300	26277

## Troubleshooting tips

The Kurt D-Series vise will operate mostly trouble free for many years. If properly maintained, this product is indestructible. In some cases it will be necessary to troubleshoot. Use the information below to help in the process.

**Problem:** My vise turns hard.

**Tip:** As a new vise the brush seal could be stiff. Allow for break in of vise.

**Tip:** As a used vise, it could be filed with chips and threads could be jammed. Properly clean and grease vise.

**Problem:** My vise will not turn in either direction.

**Tip:** The vise is jammed with debris. Disassemble and clean as needed.

**Problem:** My vise won't hold tolerance.

**Tip:** You may be experiencing jaw lift from clamping too high or on one side of the jaw. Lower the part in the vise jaw and clamp more material.

### 3 to 6 months

1. Open vise to maximum opening.
2. Remove collar and washer from hex end of the vise screw.
3. Slide the movable jaw toward the stationary.
4. Remove the thrust bearing assembly consisting of (2) thrust washers and (1) thrust bearing from the counter bore in the end of the body.
5. Clean and inspect the counter bore, thrust washers and thrust bearing.
6. Apply water resistant grease to the thrust washer (i.e. Kurt lube p/n KLA or marine grade grease)
7. Install thrust bearing assembly on the screw and slide movable jaw back.
8. Install washer and collar and tighten the set-screw.
9. Your vise is now ready to use.



### Operating Instructions

For proper vise operation insert the handle on to the hex end of the vise. Rotate clockwise to clamp and counterclockwise to unclamp your vise. This handle combined with the correct amount of torque will provide you with all the clamping force you will need to machine your parts. **DO NOT** use any other type of pressure to open or close your vise.

**The uses of handle extensions, air impact wrenches, breaker bars or hammer strikes are not recommended and will void the warranty if used.** This will also cause damage to the thrust bearing and screw threads. If you need more clamping force you may need to upgrade the vise to a larger one.

To properly clamp a part in your Kurt vise you should place the part in the center of the jaws resting on the ways of the vise. Clamping only on one side or above the movable and stationary jaws can result in jaw lift or loss of accuracy. *(See Fig. on next page)*

If one-sided clamping is necessary you **MUST** use a dummy part on the other side. When using parallels or step jaws you must select a size that keeps the bottom of the clamped part at or below the top of the movable and stationary jaws. Always use jaw plates for clamping. If jaw plates are not used damage to the mounting surface of the movable and stationary jaw will occur. This will result in reduced clamping accuracy and repeatability.

Sketch #2a  
Incorrect part  
clamping

Vise width  
centerline

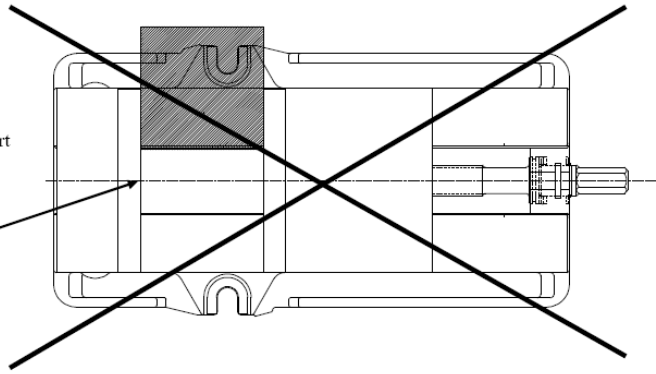

Sketch #2b  
Correct part  
clamping

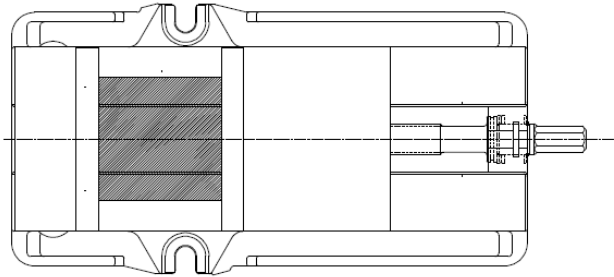

Sketch #2c  
Correct part  
clamping

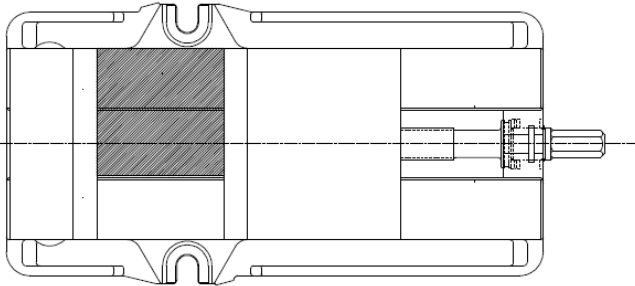

Sketch #2d  
Correct part  
clamping

Non-machined  
spacer

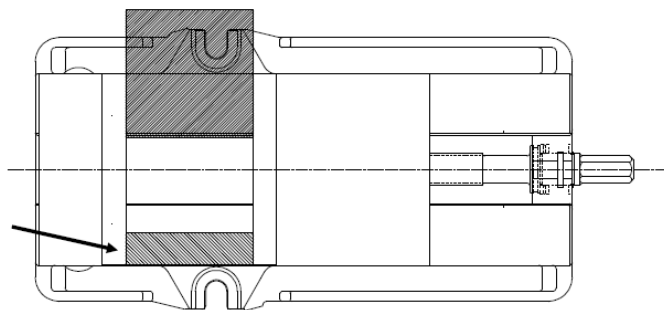

6. To re-assemble the movable jaw, apply a “glob” of grease to the under side of the movable jaw in the pocket. Place the spherical segment in the mating pocket and push into the grease. The grease will hold the segment in place when the jaw is turned over to replace.

7. Tip the jaw so the front of the jaw (the side with the jaw plate) is on the vise bed. Lower the jaw on to the bed so that the segment contact the hook part of the nut and rest the jaw on to the vise bed.

8. Tighten the setscrew to firmly contact the nut. Back off the setscrew  $\frac{1}{4}$  turn (approx.) note: **DO NOT** leave the setscrew tightened firmly to the nut as this may cause improper operation. The movable jaw is designed to move slightly (pivot side to side) so maximum jaw plate contact is maintained when clamping out-of-parallel, sawed, or cast parts.

9. Your vise is now ready for use. Open and close your vise to check for proper operation. Center the part to be clamped in the vise and close. Your parts should be centered from side to side to insure proper clamping. (*See Fig. below*)

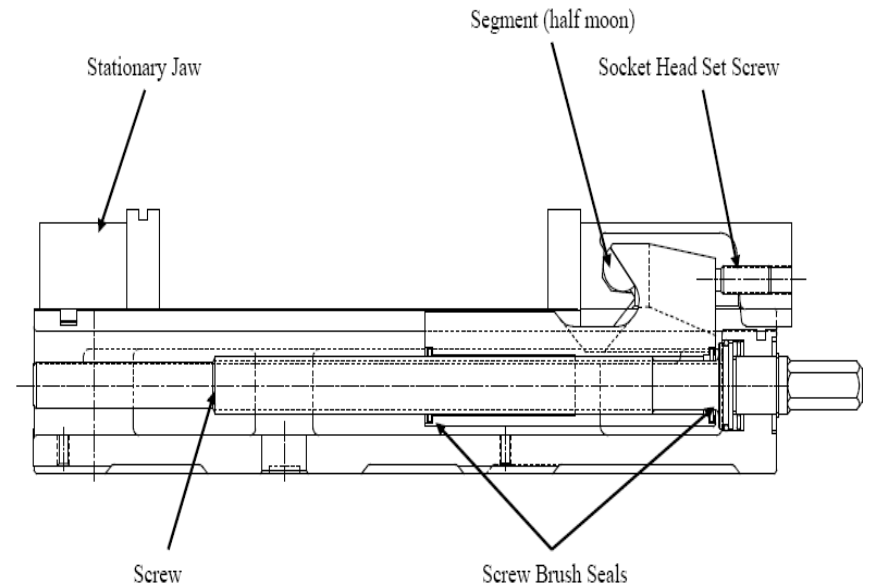

## Maintenance Schedule

It is very important to perform regularly maintenance on your Kurt vise to assure proper operation. Improper maintenance will result in poor vise performance and may void your warranty.

### **Daily/ Weekly**

1. Remove chips from surface of vise.
2. Visually inspect for chips, seals for damage and cleanliness.
3. Visually inspect for chip entrapments and remove when necessary.
4. Air-dry and apply rust inhibiting oil to the machined surface of the vise.

### **Monthly**

1. Open the vise to the maximum opening.
2. In the back of the movable jaw (handle end, center hole) loosen the socket head set screw (approx. 6 turns) With the hex key (Allen wrench) in the set-screw socket lift up and forward to pivot the Jaw off of the vise bed.
3. Slide the Jaw slightly toward the stationary jaw and lift up to remove the jaw from the “hook” of the nut. Note: A spherical segment (shaped as  $\frac{1}{2}$  of a steel ball) is inside the cavity of the movable jaw and may fall out as the jaw is removed. Take care not to lose or misplace the spherical segment.
4. Turn the movable jaw over and clean the inside cavity. Also clean the spherical segment.
5. Remove chips, clean and apply a light coat of machine oil to the machined surface of the following items:
  - a. Nut and Screw assembly (clean exposed threads on the screw),
  - b. Bed of vise (top of “rails”)
  - c. Inside of the vise between the center ways.

# D100 REPLACEMENT PARTS

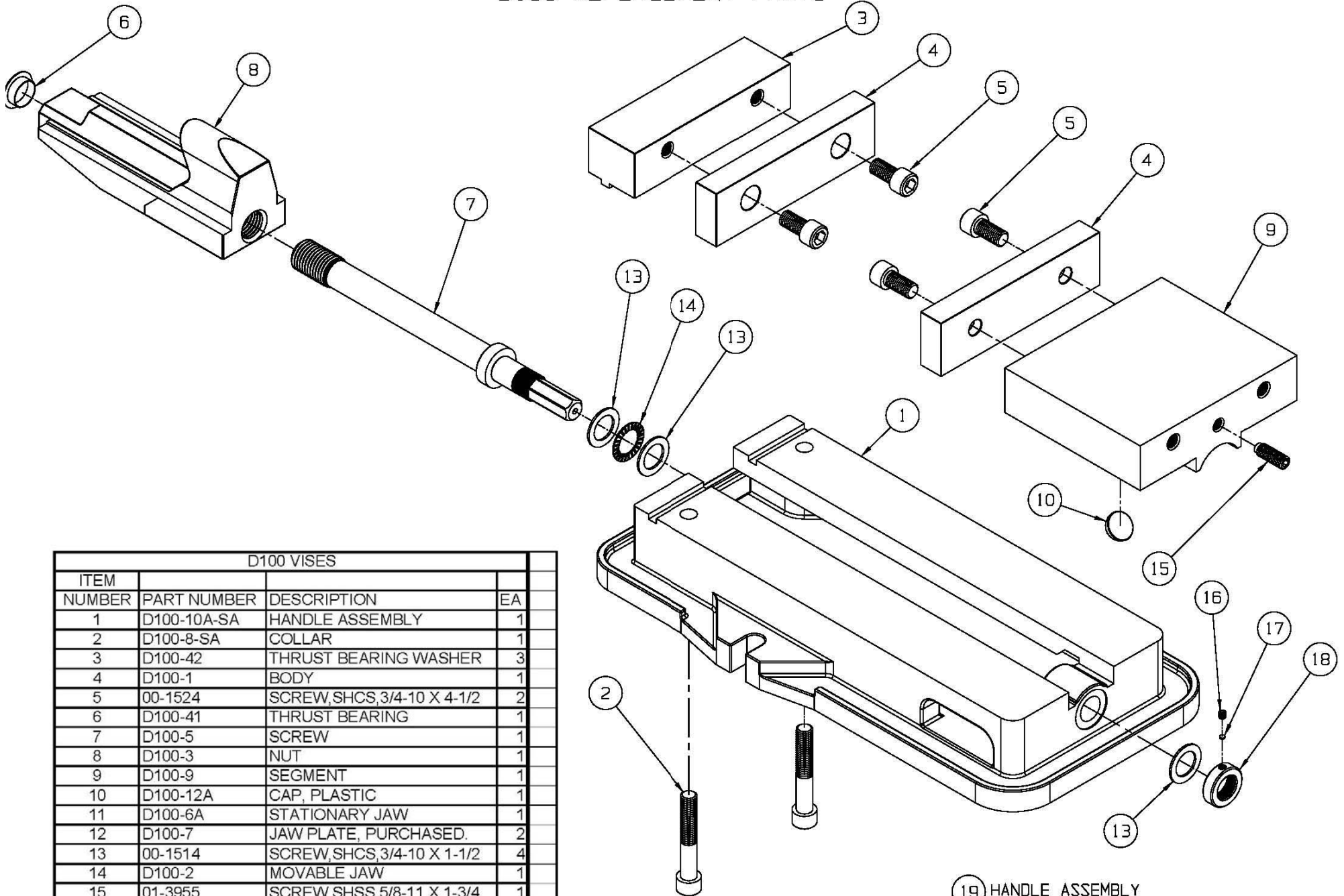

D100 VISES			
ITEM NUMBER	PART NUMBER	DESCRIPTION	EA
1	D100-10A-SA	HANDLE ASSEMBLY	1
2	D100-8-SA	COLLAR	1
3	D100-42	THRUST BEARING WASHER	3
4	D100-1	BODY	1
5	00-1524	SCREW, SHCS, 3/4-10 X 4-1/2	2
6	D100-41	THRUST BEARING	1
7	D100-5	SCREW	1
8	D100-3	NUT	1
9	D100-9	SEGMENT	1
10	D100-12A	CAP, PLASTIC	1
11	D100-6A	STATIONARY JAW	1
12	D100-7	JAW PLATE, PURCHASED.	2
13	00-1514	SCREW, SHCS, 3/4-10 X 1-1/2	4
14	D100-2	MOVABLE JAW	1
15	01-3955	SCREW, SHSS, 5/8-11 X 1-3/4	1

(19) HANDLE ASSEMBLY NOT SHOWN