



# KURT HD AND HDL VISES

PATENT PENDING

**NEW**



**HDM6 Manual**  
(shown with optional machinable aluminum jaws)



**HDHM6 Hydraulic**  
(shown with optional machinable aluminum jaws)

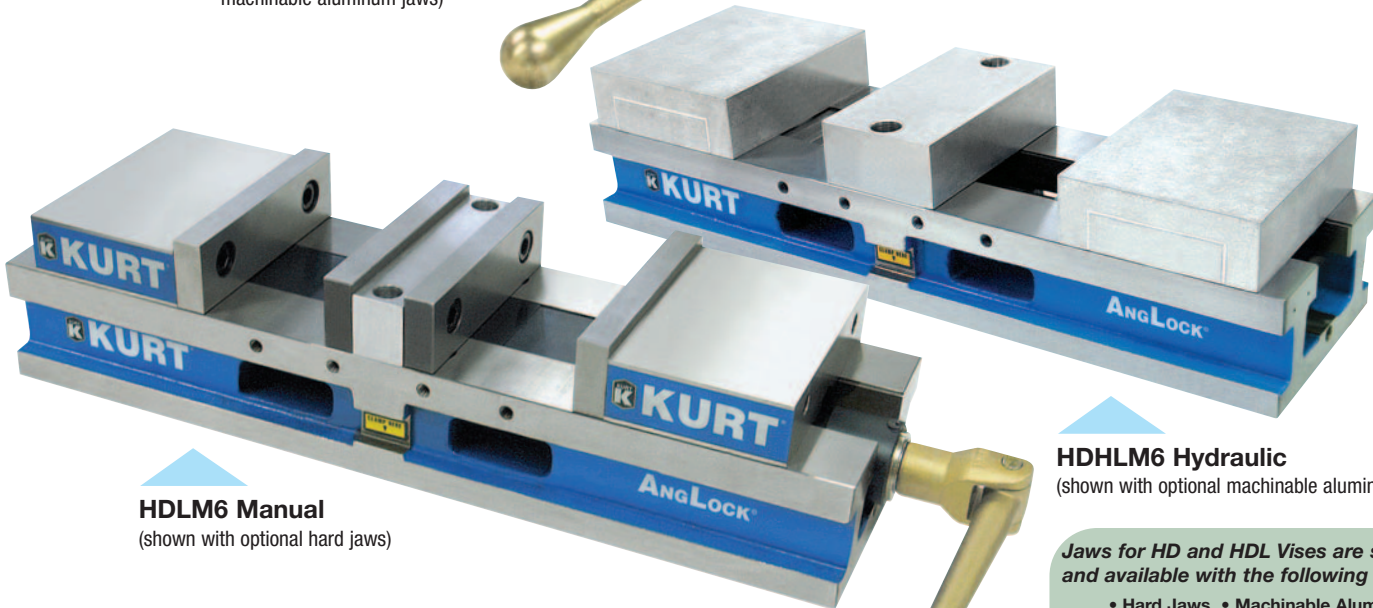

**HDLM6 Manual**  
(shown with optional hard jaws)

**HDHLM6 Hydraulic**  
(shown with optional machinable aluminum jaws)

Jaws for HD and HDL Vises are sold separately and available with the following options.

- Hard Jaws
  - Machinable Aluminum Jaws
  - Machinable Ductile Iron Jaws
  - Aluminum Fixture Plate
- See Page 8

## FASTER SETUPS FOR VISES & TOWERS

HD and HDL vises and towers have new quick change jaw feature and fewer components for faster changeovers.

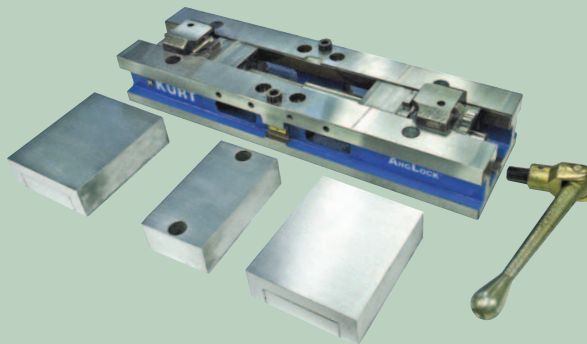

With a half turn of a hex key, the stationary jaw lifts off the vise or tower body. The jaw resets and self-aligns quickly without special tools. Spring pre-load design insures fast, easy loading of parts.

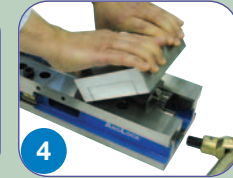

**NEW**

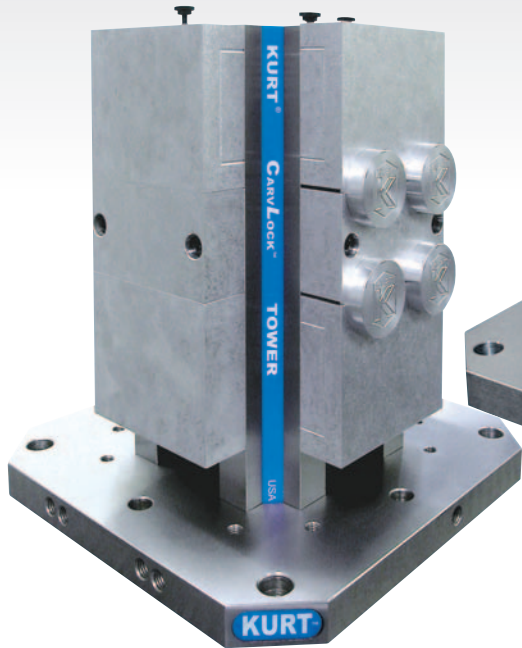

**CTHDM64 Manual**  
(shown with optional machinable aluminum jaws)

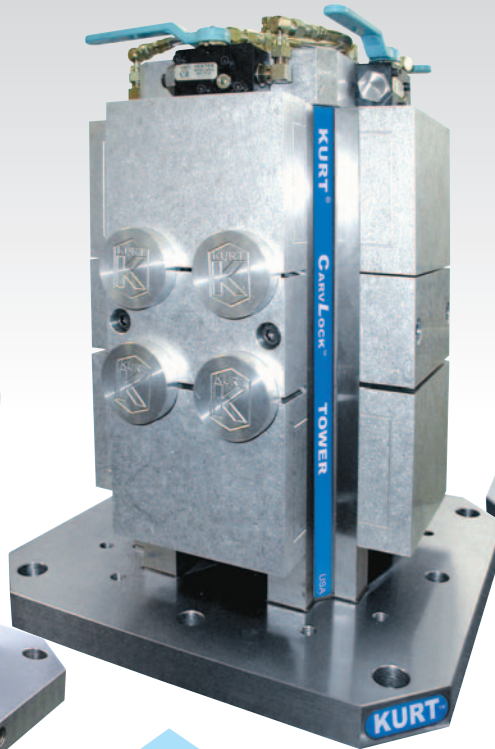

**CTHDHM64 Hydraulic**  
(shown with optional machinable aluminum jaws)

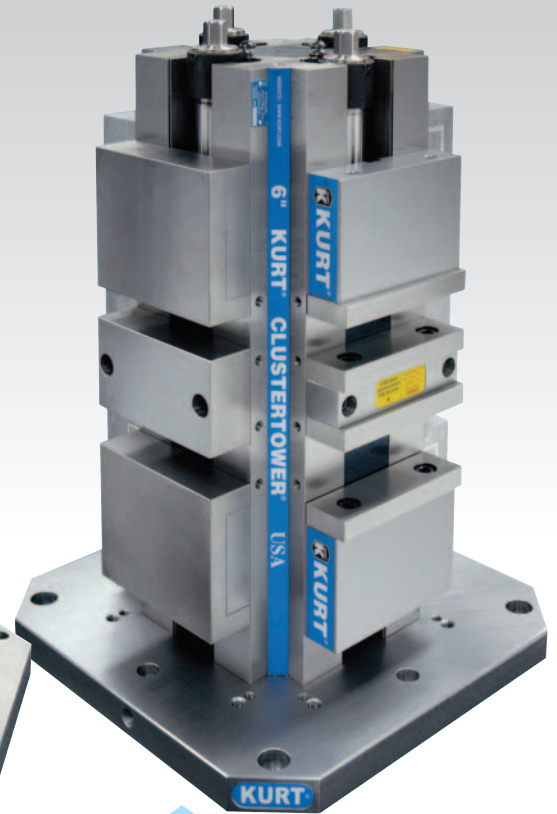

**CTHDLM644 Manual**  
(shown with optional machinable aluminum jaws on left and optional hard jaws on right)

*Jaws for HD and HDL Towers are sold separately and available with the following options.*

- Hard Jaws
  - Machinable Aluminum Jaws
  - Machinable Ductile Iron Jaws
  - Aluminum Fixture Plate
- See Page 8*

## MORE OPTIONS



**Back-to-back mounting option**

HD vises mount easily back-to-back, providing a new way to achieve a multiple clamping station tower. Contact factory for details.

Estimated shipping weight:  
88.9Kgs/196Lbs



**Fixture Plate (HD6ALP620-239)**

Ultra high density loads of small parts can be accommodated in a single setup by mounting various off-the-shelf clamping modules to this fixture plate.

To utilize this system's components, the movable and stationary vise jaws are removed and the fixture plate is positioned and then clamped by normal actuation of the vise.

**The HD product INDEX:**

**HDL Vises Pages 6-7**

**HD Vises Pages 8-9**

**HDL Towers Pages 10-11**

**HD Towers Pages 12-13**



# HDL ANgLock® VISES

**Model:**  
**HDLM6 Manual**  
**HDHLM6 Hydraulic – PATENTED**

The HDL Anglock® Vises are high density long vises with two clamping stations. They provide repeatable clamping to 0.0002" and combine high density with heavy duty features. Designed on a rugged 80,000 PSI ductile iron body with steel components, both models provide strength, rigidity and long term accuracy while absorbing machining vibration.

**Features:**

- Two clamping stations – repeatable clamping to 0.0002".
- Full 4" opening in each station with standard hard jaw system.
- Jaws are indexable 180 degrees.
- Manual and hydraulic models available.
- Fast easy conversion between manual and hydraulic models. Part # HDHLM6-3-SA-KIT.
- Maximizes the number of parts in the work envelope.
- Adjustable pre-load feature allows you to minimize pre-load range thus reducing the turns of the handle to open or close the vise (manual version).
- Holding block features the ability to clamp same or dissimilar sized parts and provides pre-loading ability in the front or back jaw (manual version).
- Lifetime Iron Clad Warranty.

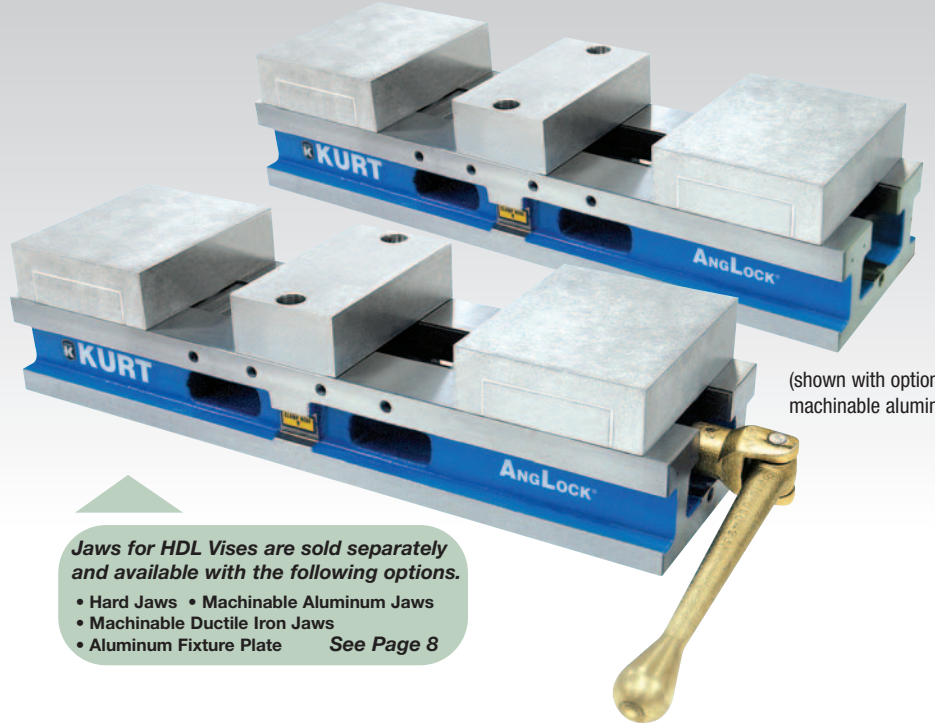

(shown with optional machinable aluminum jaws)

**Jaws for HDL Vises are sold separately and available with the following options.**

- Hard Jaws • Machinable Aluminum Jaws
- Machinable Ductile Iron Jaws
- Aluminum Fixture Plate **See Page 8**

**HARDENED JAW POSITIONS (MANUAL VISE SHOWN)**

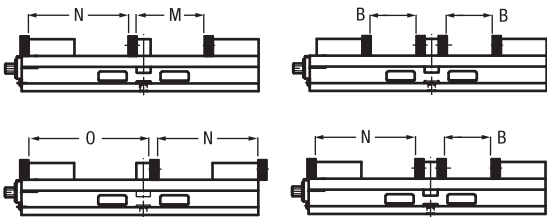

**OPTIONAL HARD JAWS (MANUAL VISE SHOWN)**

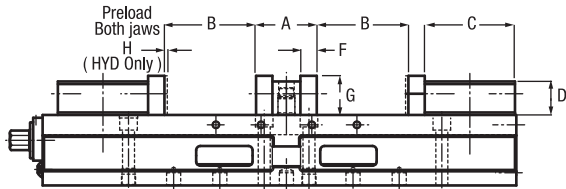

**CONVERTIBLE OPTIONAL FOR CARVABLE JAWS (MANUAL VISE SHOWN)**

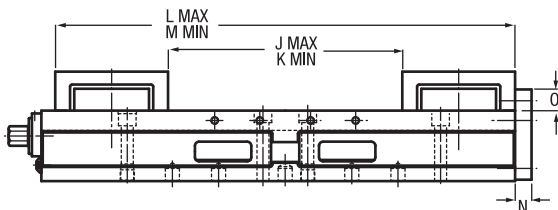

Dimensional Data High Density 6" Full Open Vise HDL Manual & Hydraulic								
	OPTIONAL HARD JAWS HDLM6J-JAWKIT Shipping Weight 11.79kgs/26lbs				Convertible OPTION HARD AND CARVABLE JAWS			
	HDLM6J		HDHLM6J		HDLM6J		HDHLM6J	
	MM	Inch	MM	Inch	MM	Inch	MM	Inch
A	68.326	2.690	68.326	2.690	271.526	10.690	271.526	10.690
B	101.600	4.000	101.600	4.000	68.326	2.690	68.326	2.690
C	101.600	4.000	101.600	4.000	289.941	11.415	289.941	11.415
D	37.719	1.485	37.719	1.485	391.541	15.415	391.541	15.415
E	152.400	6.000	152.400	6.000	308.356	12.140	308.356	12.140
F	18.415	0.725	18.415	0.725	105.156	4.140	105.156	4.140
G	44.069	1.735	44.069	1.735	86.741	3.415	86.741	3.415
H	-	-	3.175	0.125	188.341	7.415	188.341	7.415
J	98.425	3.875	98.425	3.875	274.574	10.810	274.574	10.810
K	23.876	0.940	23.876	0.940	77.775	3.062	77.775	3.062
L	M12x1.75	M12x1.75	M12x1.75	M12x1.75	528.574	20.810	528.574	20.810
M	151.511	5.965	151.511	5.965	331.775	13.062	331.775	13.062
N	221.615	8.725	221.615	8.725	18.542	0.730	18.542	0.730
O	271.526	10.690	271.526	10.690	23.825	0.938	23.825	0.938
P	-	-	-	-	15.367	0.605	15.367	0.605

**OPTIONAL CONVERTIBLE KIT (HDL6-CONVKIT) - JAW POSITIONS**

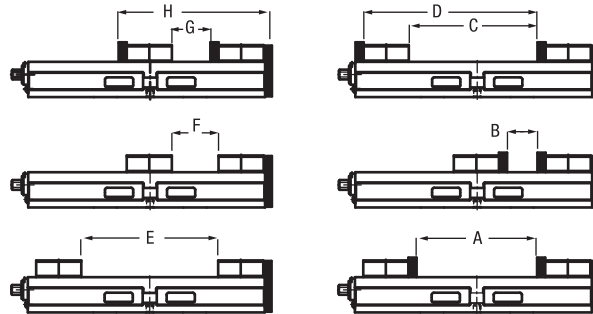

**CONVERTIBLE OPTIONAL FOR HARD JAWS HDLM6J-CONVKIT (MANUAL VISE SHOWN)**

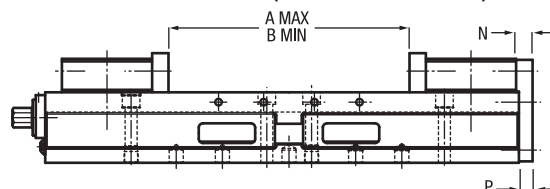

**FRONT VIEW**

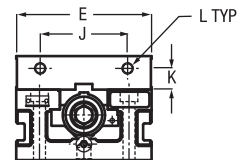

# HDL ANGLock® VISES

## ACCESSORY JAWKIT WITH OPTIONAL 2.5 HEIGHT JAW

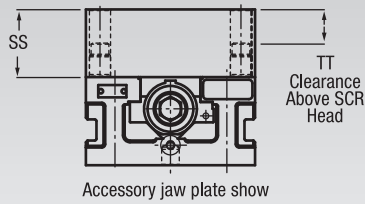

CLAMPING FORCE LBS.			
Torque-Ft. Lbs.	HDLM6	Hydraulic PSI	HDHLM6
10	1,540	500	875
20	2,520	1000	1,600
30	3,350	1500	2,330
40	4,310	2000	3,130
50	5,750	2500	3,950
60	6,860	3000	4,750
70	7,460	3500	5,475
80	8,410	4000	6,350
90	9,970	4500	7,100
		Hyd. Displacement	1.08 cubic inches

Dimensional Data				
High Density 6" Full OpenVise HDL Manual & Hydraulic				
	HDLM6		HDHLM6	
	MM	Inch	MM	Inch
A	79.375	3.125	79.375	3.125
B	152.400	6.000	152.400	6.000
C	533.400	21.000	533.400	21.000
D	258.877	10.192	258.877	10.192
E	82.550	3.250	82.550	3.250
F	539.750	21.250	539.750	21.250
G	269.875	10.625	269.875	10.625
H	36.830	1.450	-	-
J	21.844	0.860	-	-
K	63.500	2.500	63.500	2.500
L	127.000	5.000	127.000	5.000
M	127.000	5.000	127.000	5.000
N	43.891	1.728	43.891	1.728
O	152.400	6.000	152.400	6.000
P	101.600	4.000	101.600	4.000
Q	84.125	3.312	84.125	3.312
R	24.613	0.969	24.613	0.969
S	13.259	0.522	13.259	0.522
T	19.050 EXT HEX	0.750 EXT HEX	7/16-20 UNF O-RING PORT	7/16-20 UNF O-RING PORT
U	11.125	0.438	11.125	0.438
V	53.975	2.125	53.975	2.125
W	98.425	3.875	98.425	3.875
X	M10x1.5	M10x1.5	M10x1.5	M10x1.5
Y	-	-	3.175	0.125
Z	3.962	0.156	-	-
AA	15.875 INT HEX	0.625 INT HEX	15.875 INT HEX	0.625 INT HEX
BB	11.125	0.438	11.125	0.438
CC	28.575	1.125	28.575	1.125
DD	79.375	3.125	79.375	3.125
EE	M8x1.25	M8x1.25	M8x1.25	M8x1.25
FF	25.400	1.000	25.400	1.000
GG	25.000	0.984	25.000	0.984
HH	75.000	2.9528	75.000	2.9528
JJ	127.000	5.000	127.000	5.000
KK	177.800	7.000	177.800	7.000
LL	175.000	6.890	175.000	6.890
MM	50.800	2.000	50.800	2.000
NN	50.000	1.969	50.000	1.969
OO	M12 SHCS	M12 SHCS	M12 SHCS	M12 SHCS
PP	1/2 SCHS	1/2 SCHS	1/2 SCHS	1/2 SCHS
QQ	15.875	0.625	15.875	0.625
RR	16.000	0.6299	16.000	0.6299
SS	60.960	2.400	60.960	2.400
TT	30.328	1.194	30.328	1.194
	32.21 kgs/71 lbs		31.75 kgs/70 lbs	
	Estimated Shipping Weight of Vise Body Only			

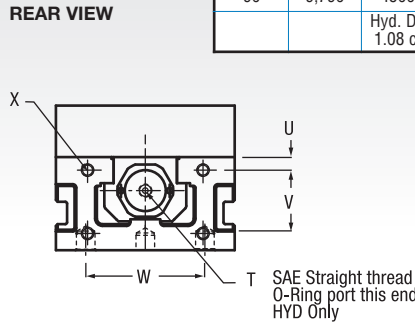
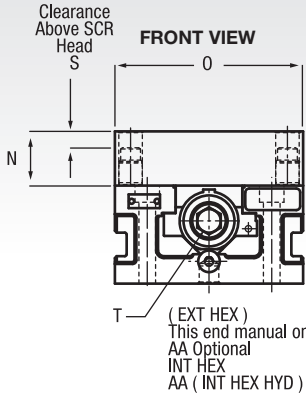

## TOP VIEW

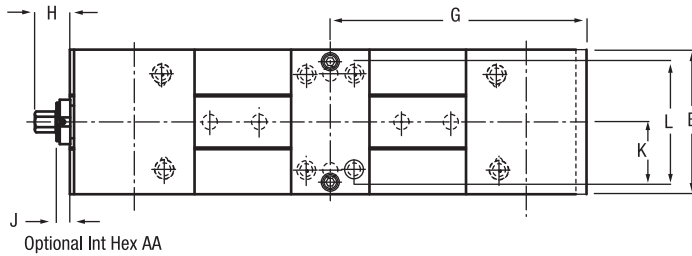

## SIDE VIEW

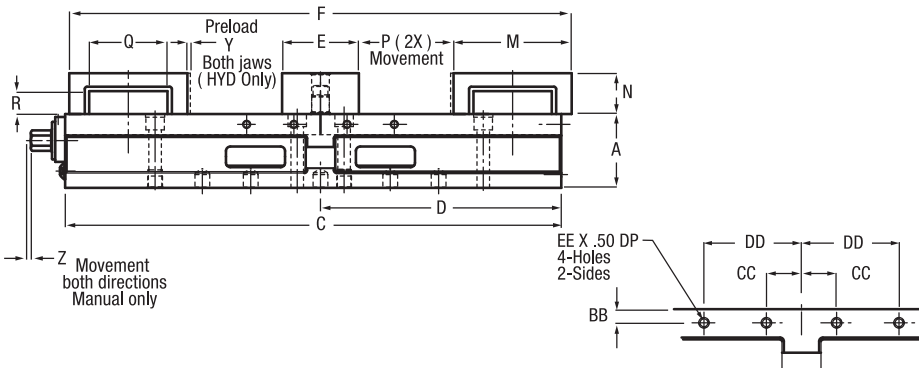

## BOTTOM VIEW

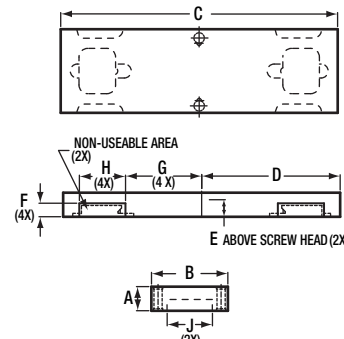
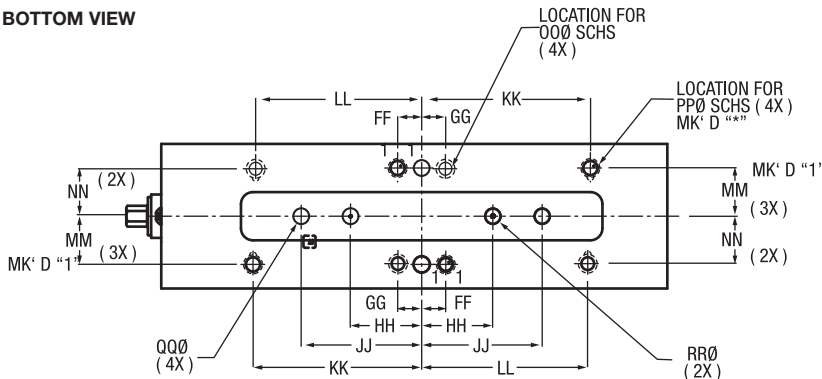

Aluminum Fixture Plate Accessory for HDLM Vise & CTHDLM Tower 6"		
	HDL6ALP619-239	
	mm	inch
A	48.260	1.900
B	152.400	6.000
C	508.000	20.000
D	254.000	10.000
E	30.988	1.220
F	24.613	0.969
G	138.938	5.470
H	84.125	3.312
J	82.550	3.250



# HD CARVLOCK® VISES

**Model:**  
**HDM6 Manual**  
**HDHM6 Hydraulic**

The HD CarvLock Vises are High-Density, Heavy-Duty systems, which are either manually or hydraulically actuated. They feature two clamping stations with machinable jaws. The overall vise is very compact, making possible maximum density workholding across the full range of today's machining centers. The HD Vise is equipped with quick change Anglock jaws in either aluminum or cast iron, depending on application requirements.



(shown with optional machinable aluminum jaws)

**Jaws for HD Vises are sold separately and available with the following options.**

- Machinable Aluminum Jaws
- Machinable Ductile Iron Jaws
- Aluminum Fixture Plate

**Features:**

- Compact size - overall length of just 13.750" and overall width of only 6".
- Clamping power/accuracy - produces up to 7,800 lbs of clamping force with repeatable clamping to 0.0002".
- Durability - 80,000 PSI ductile iron vise body for rugged strength, rigidity and long-term accuracy while absorbing machining vibration.
- Enclosed vise body keeps out chips and contaminants - makes cleanup fast and easy.
- Fast, easy conversion from manual to hydraulic. Easy to switch between both styles. Part # HDHM6-3-SA-KIT.
- Jaws are indexable 180 degrees.
- Lifetime Iron Clad Warranty.

The HDM6 Manual and HDHM6 Hydraulic vise bodies have optional jaw systems which include a set of 7075 T-6 aluminum jaw blocks or a set of ductile iron jaw blocks (1.73" standard thickness, 2.40" optional thickness) or fixture plate. Screw and nut assemblies are reversible with the vise body. One jaw kit will handle two different parts.

Jaw Kit Dimensional Data for High Density 6" HD & HDL Vises								
	HD6AL Jaw Kit		HD6AL2.5 Jaw Kit		HD6C Jaw Kit		HD6ALP620-239 Fixture Plate	
	MM	Inch	MM	Inch	MM	Inch	MM	Inch
A	43.891	1.728	60.960	2.400	43.891	1.728	50.290	1.980
B	152.400	6.000	152.400	6.000	152.400	6.000	152.400	6.000
C	127.000	5.000	127.000	5.000	127.000	5.000	355.600	14.000
D	82.550	3.250	82.550	3.250	82.550	3.250	-	-
E	84.120	3.312	84.120	3.312	84.120	3.312	84.120	3.312
F	24.160	0.951	24.160	0.951	24.160	0.951	24.610	0.969
G	13.260	0.522	30.330	1.190	13.260	0.522	-	-
H	349.250	13.750	349.250	13.750	349.250	13.750	-	-
J	-	-	-	-	-	-	177.800	7.000
K	-	-	-	-	-	-	62.710	2.469
L	-	-	-	-	-	-	82.550	3.250
Est Ship Wt.Kgs/Lbs.	5.4	12	8.6	19	17.7	39	6.4	14

**Note: For threaded style stationary jaws, add an "M" after the "D" to the part number above.**

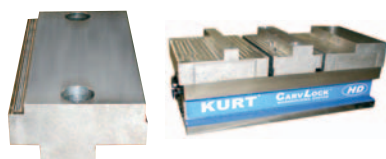
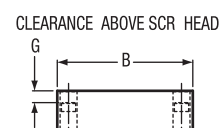
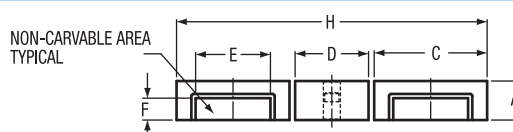
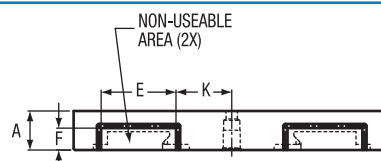
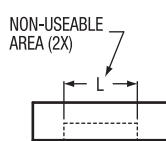
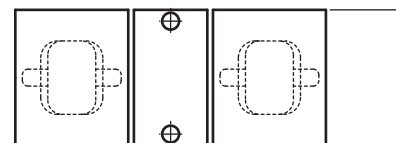
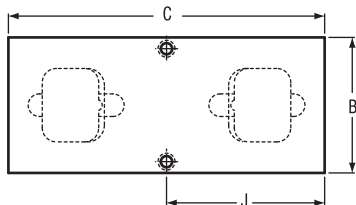

Photographs above show machined jaws on two sides. Photographs courtesy of Precise Products Corp.

# HD CARVLOCK® VISES

Clamping Force LBS.			
Torque-Ft. Lbs.	HDM6	Hydraulic PSI	HDHM6
10	883	500	875
20	1,684	1000	1,600
30	2,503	1500	2,330
40	3,187	2000	3,130
50	3,963	2500	3,950
60	4,837	3000	4,750
70	5,556	3500	5,475
		4000	6,350
		4500	7,100
		5000	7,800
		Hyd. Displacement 1.08 cubic inches	

TOP VIEW

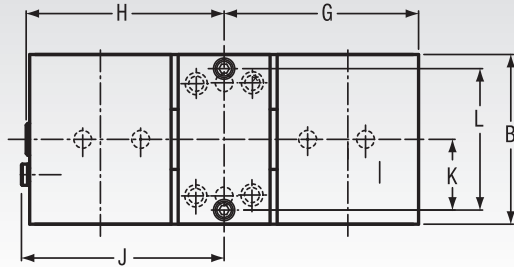

	Dimensional Data High Density 6 HD Vise Manual & Hydraulic			
	HDM6		HDHM6	
	MM	Inch	MM	Inch
A	79.375	3.125	79.375	3.125
B	152.400	6.000	152.400	6.000
C	339.725	13.375	339.725	13.375
D	169.875	6.688	169.875	6.688
E	82.550	3.250	82.550	3.250
F	349.250	13.750	349.250	13.750
G	174.625	6.875	174.625	6.875
H	177.800	7.000	174.630	6.875
J	182.040	7.167	-	-
K	63.500	2.500	63.500	2.500
L	127.000	5.000	127.000	5.000
M	127.000	5.000	127.000	5.000
N	43.891	1.728	43.891	1.728
O	152.400	6.000	152.400	6.000
P	6.350	0.250	6.350	0.250
Q	84.120	3.312	84.120	3.312
R	24.610	0.969	24.610	0.969
S	13.260	0.522	13.260	0.522
T	15.875 INT. HEX	0.625 INT. HEX	7/16-20 UNF O-RING PORT	7/16-20 UNF O-RING PORT
U	11.125	0.438	11.125	0.438
V	53.975	2.125	53.975	2.125
W	98.425	3.875	98.425	3.875
X	M10 x 1.5	M10 x 1.5	M10 x 1.5	M10 x 1.5
Z	25.400	1.000	25.400	1.000
AA	25.000	0.984	25.000	0.984
BB	75.000	2.953	75.000	2.953
CC	127.000	5.000	127.000	5.000
DD	50.000	1.969	50.000	1.969
EE	50.800	2.000	50.800	2.000
GG	1/2	1/2	1/2	1/2
HH	M12	M12	M12	M12
JJ	15.875	0.625	15.875	0.625
KK	16.000	0.630	16.000	0.630
LL	77.770	3.062	82.550	3.250
MM	90.470	3.562	95.250	3.750
NN	23.830	0.938	23.830	0.938
OO	18.540	0.730	18.540	0.730
PP	30.630	1.206	30.630	1.206
QQ	331.770	13.062	336.550	13.250
RR	344.470	13.562	349.250	13.750
SS	60.960	2.400	60.960	2.400
TT	30.330	1.190	30.330	1.190
UU	-	-	3.180	0.125
VV	-	-	9.530	0.375

Estimated Shipping Weight of Vise Body Only 21.8 Kgs (48 lbs)

BOTTOM VIEW

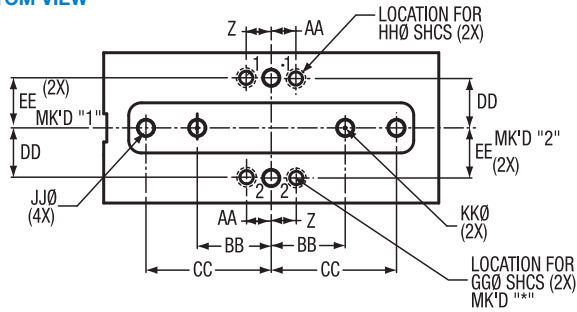

REAR VIEW

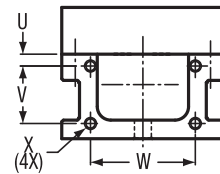

SIDE VIEW

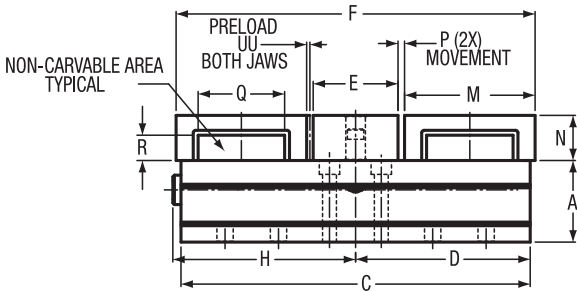

FRONT VIEW

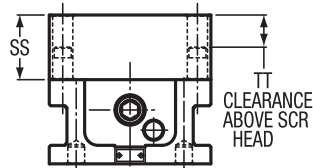

ACCESSORY JAW PLATE SHOWN WITH OPTIONAL 2.5 HEIGHT JAW

Convertible Kits for Optional Machinable Jaws - Part Number HDM6-CONVKIT

SIDE VIEW

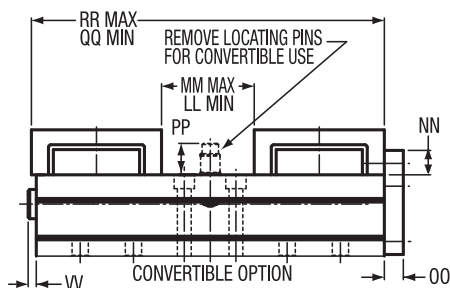

FRONT VIEW

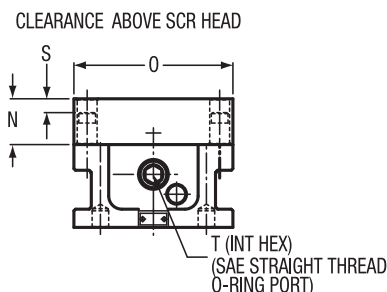

HD6ALP620-239 FIXTURE PLATE

Ultra high density loads of small parts can be accommodated in a single setup by mounting various off-the-shelf clamping modules to this fixture plate.

To utilize this system's components, the movable and stationary vise jaws are removed and the fixture plate is positioned and then clamped by normal actuation of the vise.



# HDL CARVLOCK® TOWERS

**Models:**

- CTHDLM644**
- CTHDLM645**
- CTHDLM646**

This manually operated, eight station HDL Cluster Tower system features a ductile iron integral vise tower. Designed for use on mid-size and larger machining centers including horizontal and vertical machining centers with a fourth axis and indexable tables. This workholding system achieves workpiece immobility while damping cutter induced vibration.

**Features:**

- High density vise tower system. Hold multiple parts in eight clamping stations. Increase part volume.
- Repeatable clamping to 0.0002". Each station delivers up to 6,316 lbs. of clamping force at 70 ft lbs of torque.
- Self-adjusting holding block of either front or back jaw for clamping the same or dissimilar sized parts. To further enhance fast operation, an adjustable pre-load feature reduces handle turns for opening and closing clamping stations.
- Ductile iron column insures strength, rigidity and long term accuracy.
- Jaw options available to fit your application. Select from Hard jaws, Machinable aluminum jaws, Machinable ductile Iron jaws and Aluminum fixture plate.
- Jaws are indexable 180 degrees.
- Base sizes available include: 400mm, 500mm, 630mm.
- Elevated column makes clearing chips and contaminants fast and easy.
- Lifetime Iron Clad Warranty.

CLAMPING FORCE LBS.			
Torque- Ft. Lbs.	HDLM6	Hydraulic PSI	HDHLM6
10	1,540	500	875
20	2,520	1000	1,600
30	3,350	1500	2,330
40	4,310	2000	3,130
50	5,750	2500	3,950
60	6,860	3000	4,750
70	7,460	3500	5,475
80	8,410	4000	6,350
90	9,790	4500	7,100
		Hyd. Displacement 1.08 cubic inches	

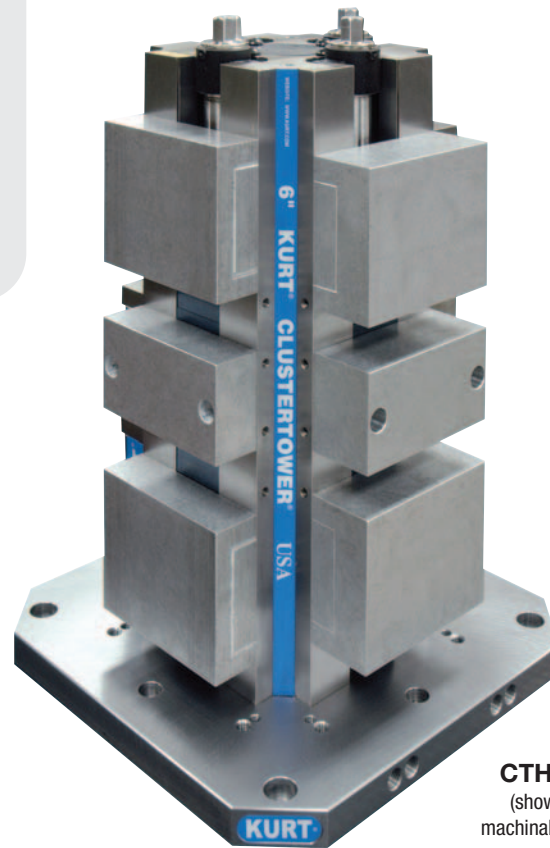
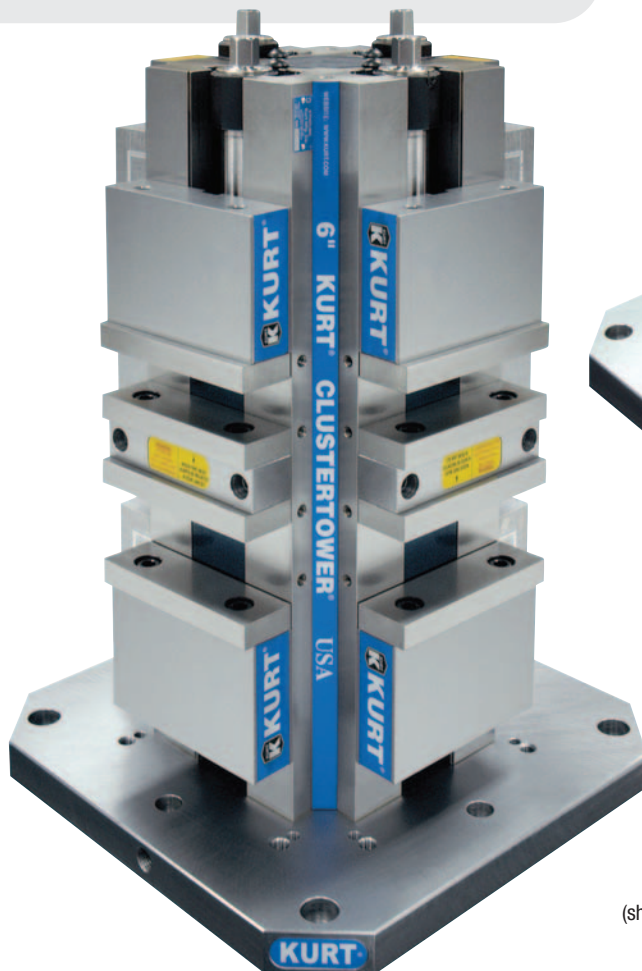

**CTHDLM644AL**  
(shown with optional machinable aluminum jaws)

*Jaws for HDL Towers are sold separately and available with the following options.*

- Hard Jaws • Machinable Aluminum Jaws
- Machinable Ductile Iron Jaws
- Aluminum Fixture Plate **See Page 8**

**CTHDLM644J**  
(shown with optional hard jaws)

# HDL CARVLOCK® TOWERS

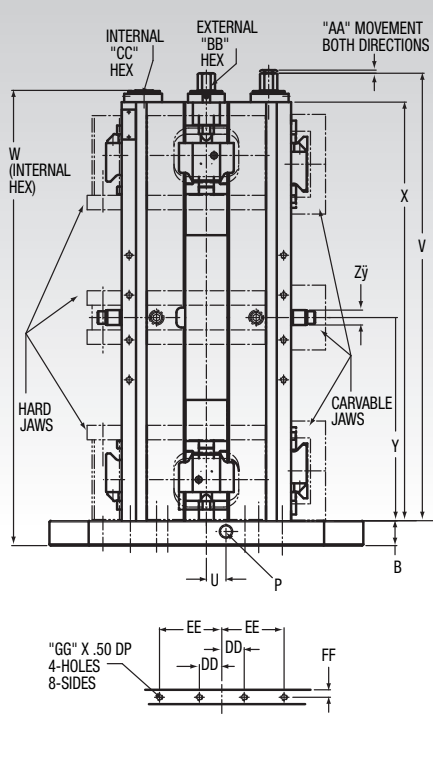
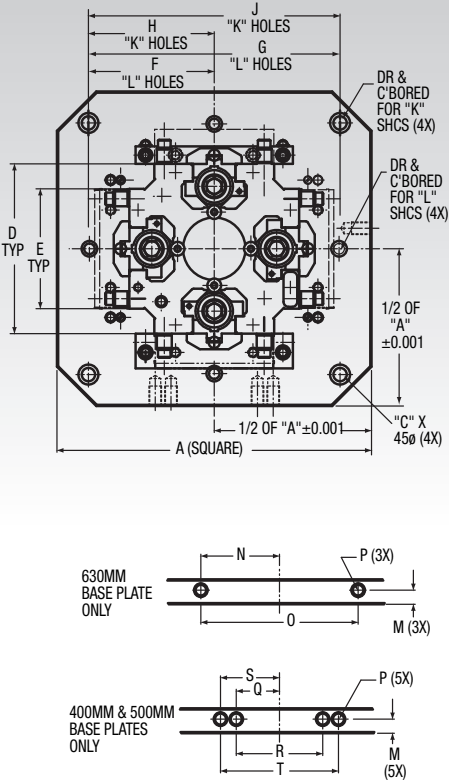

Dimensional Data HDL Long Cluster Tower						
	CTHDLM644		CTHDLM645		CTHDLM646	
	MM	Inch	MM	Inch	MM	Inch
A	400.000	15.748	500.000	19.685	630.000	24.803
B	31.750	1.250	31.750	1.250	38.100	1.500
C	50.000	1.970	60.000	2.360	70.000	2.760
D	215.900	8.500	215.900	8.500	215.900	8.500
E	152.400	6.000	152.400	6.000	152.400	6.000
F	158.750	6.250	203.200	8.000	254.000	10.000
G	317.500	12.500	406.400	16.000	508.000	20.000
H	160.000	6.299	200.000	7.874	250.000	9.842
J	320.000	12.598	400.000	15.748	500.000	19.685
K	M16SHCS	5/8 SHCS	M16SHCS	5/8 SHCS	M16SHCS	5/8 SHCS
L	M12SHCS	1/2 SHCS	M12SHCS	1/2 SHCS	M12SHCS	1/2 SHCS
M	18.000	0.709	18.000	0.709	18.000	0.709
N	-	-	-	-	100.000	3.937
O	-	-	-	-	200.000	7.874
P	M16 x 2.0	-	M16 x 2.0	-	M16 x 2.0	-
Q	55.000	2.165	55.000	2.165	-	-
R	110.000	4.330	110.000	4.330	-	-
S	75.000	2.953	75.000	2.953	-	-
T	150.000	5.906	150.000	5.906	-	-
U	25.000	0.984	25.000	0.984	25.000	0.984
V	570.230	22.450	570.230	22.450	570.230	22.450
W	548.380	21.590	548.380	21.590	548.380	21.590
X	533.400	21.000	533.400	21.000	533.400	21.000
Y	258.880	10.192	258.880	10.192	258.880	10.192
Z	19.050	0.750	19.050	0.750	19.050	0.750
AA	3.960	0.156	3.960	0.156	3.960	0.156
BB	19.050	0.750	19.050	0.750	19.050	0.750
CC	15.875	0.625	15.875	0.625	15.875	0.625
DD	28.580	1.125	28.580	1.125	28.580	1.125
EE	79.380	3.125	79.380	3.125	79.380	3.125
FF	9.530	0.375	9.530	0.375	9.530	0.375
GG	M8 x 1.25	-	M8 x 1.25	-	M8 x 1.25	-

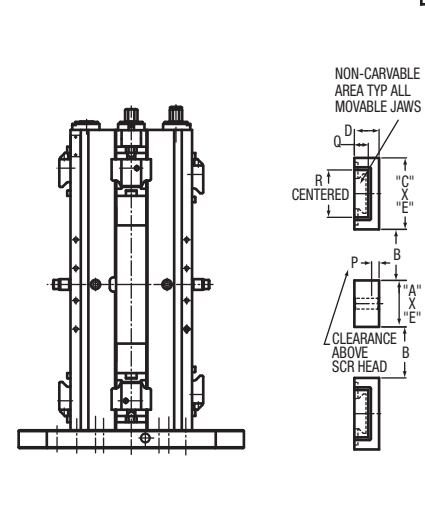
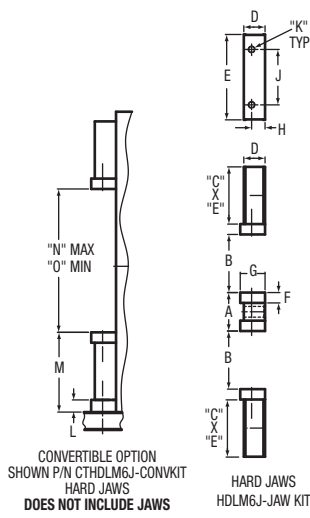

Jaw Accessories						
	HARD JAWS		ALUMINUM JAWS			
	HDLM6J-Jaw Kit		HD6AL-Jaw Kit		HD6AL2.5-Jaw Kit	
	MM	Inch	MM	Inch	MM	Inch
A	68.326	2.690	82.550	3.250	82.550	3.250
B	103.170	4.062	90.630	3.568	90.630	3.568
C	101.600	4.000	127.000	5.000	127.000	5.000
D	37.719	1.485	43.890	1.728	60.960	2.400
E	151.610	5.968	152.400	6.000	152.400	6.000
F	18.415	0.725	-	-	-	-
G	44.069	1.735	-	-	-	-
H	23.876	0.940	-	-	-	-
J	98.425	3.875	-	-	-	-
K	M12 x 1.75	-	-	-	-	-
L	-	-	-	-	-	-
M	-	-	-	-	-	-
N	-	-	-	-	-	-
O	-	-	-	-	-	-
P	-	-	13.260	0.522	30.330	1.194
Q	-	-	24.610	0.969	24.610	0.969
R	-	-	84.120	3.312	84.120	3.312

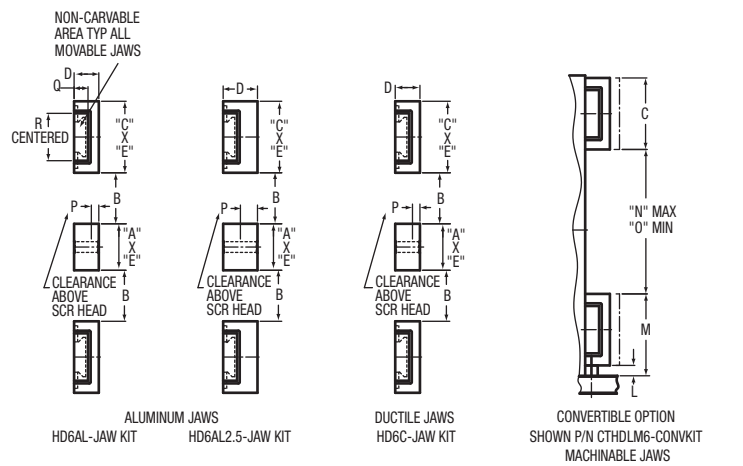

Jaw Accessories Convertible Option						
	DUCTILE JAWS		HARD JAWS		CARVABLE JAWS	
	HD6C-Jaw Kit		CTHDLM6J-CONVKIT		CTHDLM6-CONVKIT	
	MM	Inch	MM	Inch	MM	Inch
A	82.550	3.250	-	-	-	-
B	90.630	3.568	-	-	-	-
C	127.000	5.000	-	-	-	-
D	43.891	1.728	-	-	-	-
E	152.400	6.000	-	-	-	-
F	-	-	-	-	-	-
G	-	-	-	-	-	-
H	-	-	-	-	-	-
J	-	-	-	-	-	-
K	-	-	-	-	-	-
L	-	-	21.590	0.850	18.415	0.725
M	-	-	141.605	5.575	145.415	5.725
N	-	-	254.640	10.025	256.540	10.100
O	-	-	68.326	2.690	79.760	3.140
P	13.260	0.522	-	-	-	-
Q	24.610	0.969	-	-	-	-
R	84.120	3.312	-	-	-	-





# HD CARVLOCK® TOWERS

**Model:**  
**CTHDM64**

This manually operated, eight station HD Cluster Tower system features a cast iron integral vise tower. Ideal for horizontal machining centers or vertical machining centers with indexable tables. This workholding system achieves workpiece immobility while damping cutter induced vibration.

**Features:**

- Most compact, high density vise tower system in the industry.
- Hold multiple parts in eight clamping stations. Increase part volume.
- Small footprint which reduces spindle travel, part to part, maximizing throughput without compromising holding accuracy.
- Ductile iron column insures strength, rigidity and long term accuracy.
- Jaw options available to fit your application. Select from Machinable aluminum jaws, Machinable ductile Iron jaws and Aluminum fixture plate.
- Jaws are indexable 180 degrees.
- Base sizes available include: 300mm, 400mm, 500mm, 630mm.
- Elevated column makes clearing chips and contaminants fast and easy.
- Can be converted to hydraulic actuation.
- Lifetime Iron Clad Warranty.

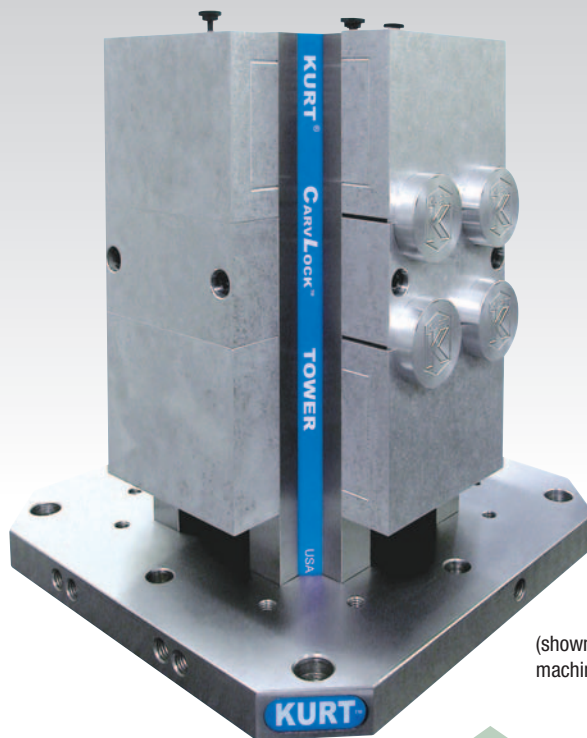

(shown with optional machinable aluminum jaws)

**Jaws for HD Towers are sold separately and available with the following options.**

- Machinable Aluminum Jaws
- Machinable Ductile Iron Jaws
- Aluminum Fixture Plate **See Page 8**

**Model:**  
**CTHDHM64**

Identical in capacity and features as the manual HD CarvLock Tower system, this system is actuated hydraulically. Hydraulic piston is an integral part of the vise nut within the vise and tower body to conserve valuable space on the machine table. This hydraulic version also shares all of the jaw options and other accessories which are available in the manual version. This hydraulic system has the added advantage of converting easily in minutes to manual operation by swapping out internal components. Hydraulic pump and hose not included.

**Features:**

- Up to 7,100 pounds of clamping force.
- Jaw options available to fit your application. Select from Machinable aluminum jaws, Machinable ductile Iron jaws and Aluminum fixture plate.
- Jaws are indexable 180 degrees.
- Elevated column makes clearing chips and contaminants fast and easy.
- Base sizes available include: 300mm, 400mm, 500mm, 630mm.
- Lifetime Iron Clad Warranty.

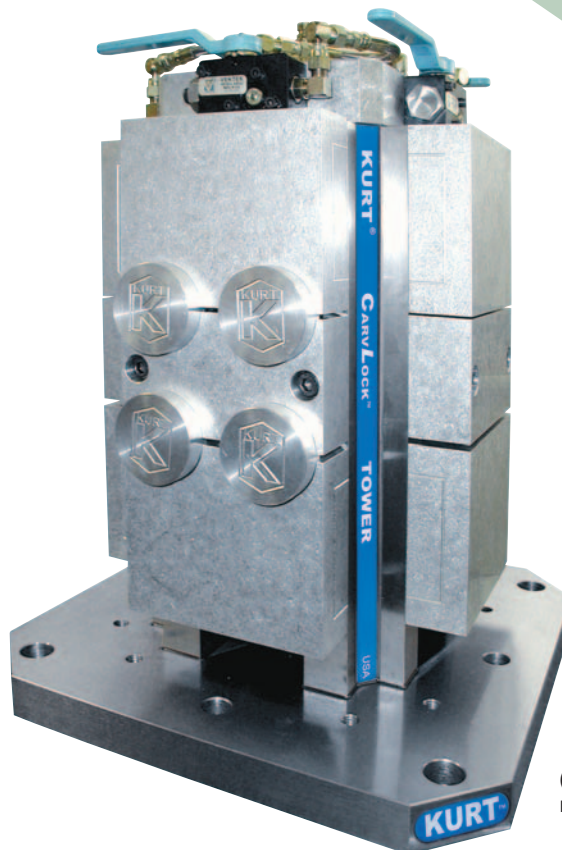

(shown with optional machinable aluminum jaws)

(See Page 14 for model CTHDHM64 Specifications)

# HD CARVLOCK® TOWERS

## CTHDM64 Specifications (See Page 14 for model CTHDHM64 Specifications)

CLAMPING FORCE LBS.	
Torque-Ft. Lbs.	HDM6
10	883
20	1,684
30	2,503
40	3,187
50	3,963
60	4,837
70	5,556

TOP VIEW

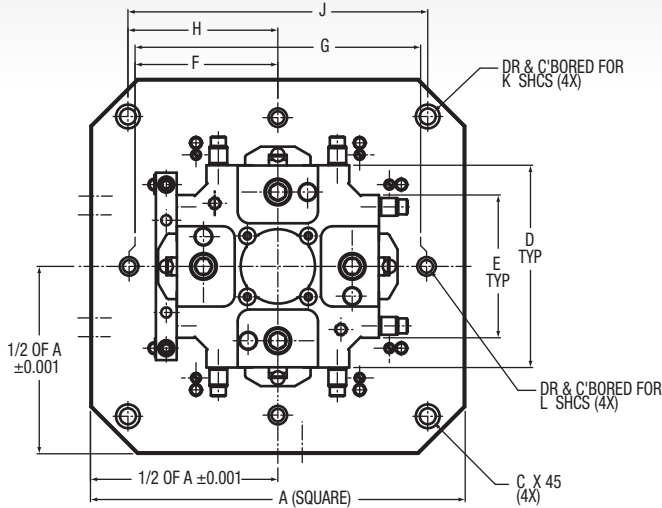

SIDE VIEW

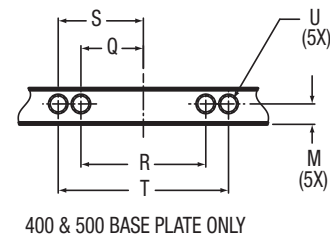
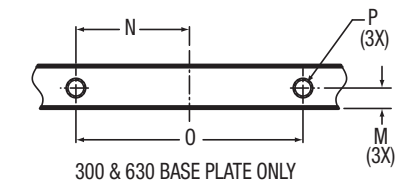
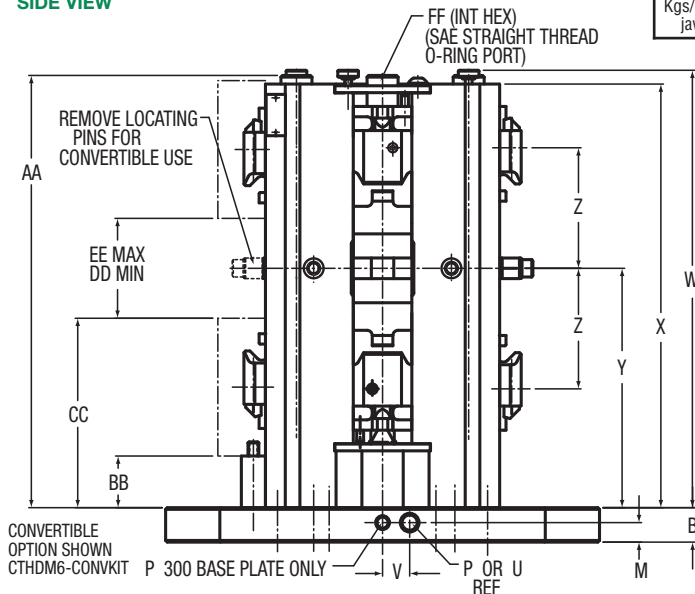

	HD MANUAL TOWER DIMENSIONS							
	CTHDM643		CTHDM644		CTHDM645		CTHDM646	
	MM	Inch	MM	Inch	MM	Inch	MM	Inch
A	300.000	11.811	400.000	15.748	500.000	19.685	630.000	24.803
B	25.400	1.000	31.750	1.250	31.750	1.250	38.100	1.500
C	20.000	0.787	50.000	1.969	60.000	2.362	70.100	2.760
D	215.900	8.500	215.900	8.500	215.900	8.500	215.900	8.500
E	152.400	6.000	152.400	6.000	152.400	6.000	152.400	6.000
F	-	-	158.750	6.250	203.200	8.000	254.000	10.000
G	-	-	317.500	12.500	406.400	16.000	508.000	20.000
H	127.000	5.000	160.000	6.299	200.000	7.874	250.000	9.843
J	254.000	10.000	320.000	12.598	400.000	15.748	500.000	19.685
K	M12	M12	M16	M16	M16	M16	M16	M16
L	-	-	M12	M12	M12	M12	M12	M12
M	15.000	0.591	18.000	0.709	18.000	0.709	18.000	0.709
N	40.000	1.575	-	-	-	-	100.000	3.937
O	80.000	3.150	-	-	-	-	200.000	7.874
P	M12x1.75	M12x1.75	-	-	-	-	M16x2.0	M16x2.0
Q	-	-	55.000	2.165	55.000	2.165	-	-
R	-	-	110.000	4.331	110.000	4.331	-	-
S	-	-	75.000	2.953	75.000	2.953	-	-
T	-	-	150.000	5.906	150.000	5.906	-	-
U	-	-	M16x2.0	M16x2.0	M16x2.0	M16x2.0	-	-
V	-	-	25.000	0.984	25.000	0.984	25.000	0.984
W	403.230	15.875	403.230	15.875	403.230	15.875	403.230	15.875
X	390.520	15.375	390.520	15.375	390.520	15.375	390.520	15.375
Y	220.680	8.688	220.680	8.688	220.680	8.688	220.680	8.688
Z	111.130	4.375	111.130	4.375	111.130	4.375	111.130	4.375
AA	398.480	15.688	398.480	15.688	398.480	15.688	398.480	15.688
BB	47.625	1.875	47.625	1.875	47.625	1.875	47.625	1.875
CC	174.625	6.875	174.625	6.875	174.625	6.875	174.625	6.875
DD	82.550	3.250	82.550	3.250	82.550	3.250	82.550	3.250
EE	92.080	3.625	92.080	3.625	92.080	3.625	92.080	3.625
FF	15.875 INT. HEX	0.625 INT. HEX	15.875 INT. HEX	0.625 INT. HEX	15.875 INT. HEX	0.625 INT. HEX	15.875 INT. HEX	0.625 INT. HEX
Approx. Ship weight Kgs/Lbs with jaw sets	139.7	308	161.0	355	183.7	405	239.5	528



HYDRAULIC

# HD CARVLOCK® TOWERS

## CTHDM64 Specifications

HD HYDRAULIC TOWER DIMENSIONS								
	CTHDM643		CTHDM644		CTHDM645		CTHDM646	
	MM	Inch	MM	Inch	MM	Inch	MM	Inch
A	300.000	11.811	400.000	15.748	500.000	19.685	630.000	24.803
B	25.400	1.000	31.750	1.250	31.750	1.250	38.100	1.500
C	20.000	0.787	50.000	1.969	60.000	2.362	70.100	2.760
D	215.900	8.500	215.900	8.500	215.900	8.500	215.900	8.500
E	152.400	6.000	152.400	6.000	152.400	6.000	152.400	6.000
F	-	-	158.750	6.250	203.200	8.000	254.000	10.000
G	-	-	317.500	12.500	406.400	16.000	508.000	20.000
H	127.000	5.000	160.000	6.299	200.000	7.874	250.000	9.843
J	254.000	10.000	320.000	12.598	400.000	15.748	500.000	19.685
K	M12	M12	M16	M16	M16	M16	M16	M16
L	-	-	M12	M12	M12	M12	M12	M12
M	15.000	0.591	18.000	0.709	18.000	0.709	18.000	0.709
N	40.000	1.575	-	-	-	-	100.000	3.937
O	80.000	3.150	-	-	-	-	200.000	7.874
P	M12 x 1.75	M12 x 1.75	-	-	-	-	M16 x 2.0	M16 x 2.0
Q	-	-	55.000	2.165	55.000	2.165	-	-
R	-	-	110.000	4.331	110.000	4.331	-	-
S	-	-	75.000	2.953	75.000	2.953	-	-
T	-	-	150.000	5.906	150.000	5.906	-	-
U	-	-	M16 x 2.0	M16 x 2.0	M16 x 2.0	M16 x 2.0	-	-
V	-	-	25.000	0.984	25.000	0.984	25.000	0.984
W	487.170	19.180	487.170	19.180	487.170	19.180	487.170	19.180
X	390.520	15.375	390.520	15.375	390.520	15.375	390.520	15.375
Y	220.680	8.688	220.680	8.688	220.680	8.688	220.680	8.688
Z	127.000	5.000	127.000	5.000	127.000	5.000	127.000	5.000
AA	6.350	0.250	6.350	0.250	6.350	0.250	6.350	0.250
BB	47.625	1.875	47.625	1.875	47.625	1.875	47.625	1.875
CC	174.625	6.875	174.625	6.875	174.625	6.875	174.625	6.875
DD	82.550	3.250	82.550	3.250	82.550	3.250	82.550	3.250
EE	95.250	3.750	95.250	3.750	95.250	3.750	95.250	3.750
FF	82.550	3.250	82.550	3.250	82.550	3.250	82.550	3.250
Approx. Ship weight Kgs/Lbs with jaw sets	148.8	328	170.1	375	192.8	425	248.6	548

CLAMPING FORCE LBS.	
Hydraulic PSI	HDHM6
500	875
1000	1600
1500	2330
2000	3130
2500	3950
3000	4750
3500	5475
4000	6350
4500	7100
5000	7800
Hyd. Displacement cu. in.	1.08

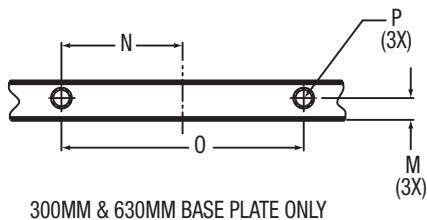
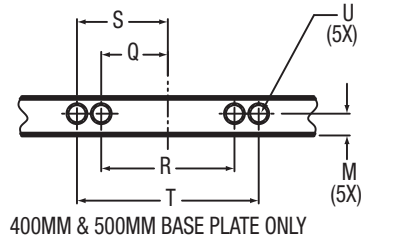
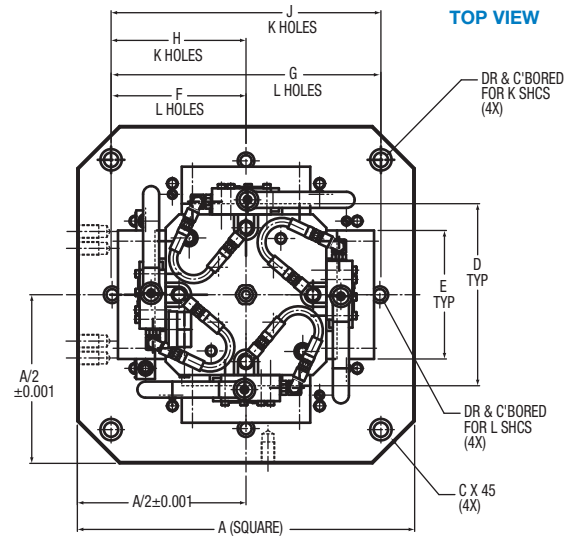
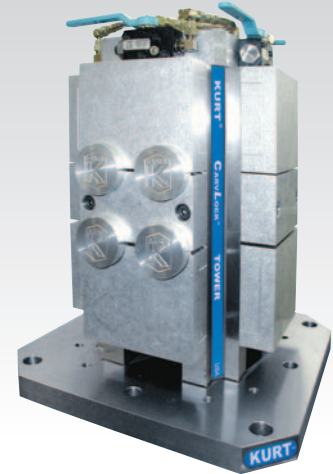

### SIDE VIEW

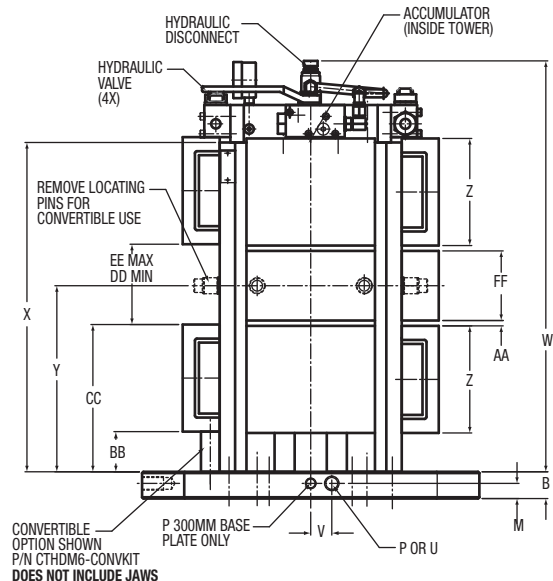

# HD/HDL VISE

HDLM6AL (Manual 6" vise with standard aluminum jaws.)  
 HDLHM6AL2.5 (Hydraulic vise with optional height aluminum jaws.)



### HDL Double Station Vise Examples:

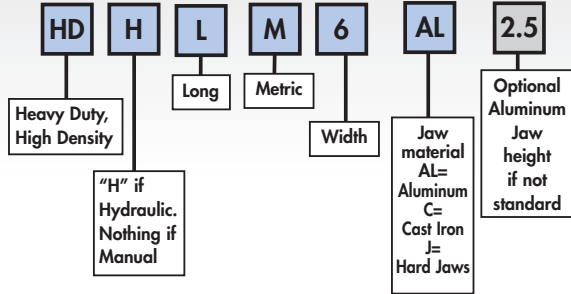

HDM6AL (Manual 6" vise with standard aluminum jaws.)  
 HDHM6AL2.5 (Hydraulic vise with optional height aluminum jaws.)



### HD Double Station Vise Examples:

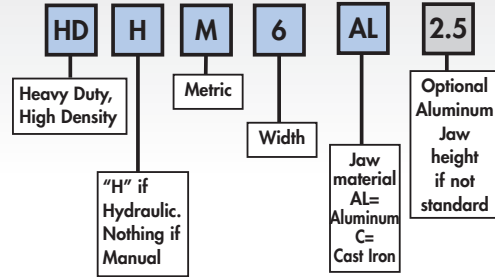

CTHDM643AL (Manual 6" tower with 4 sides, 300mm base with standard height aluminum jaws.)  
 CTHDHM645AL2.5 (Hydraulic 6" tower with 4 sides, 500mm base with optional height aluminum jaws.)



### HD and HDL ClusterTower Examples:

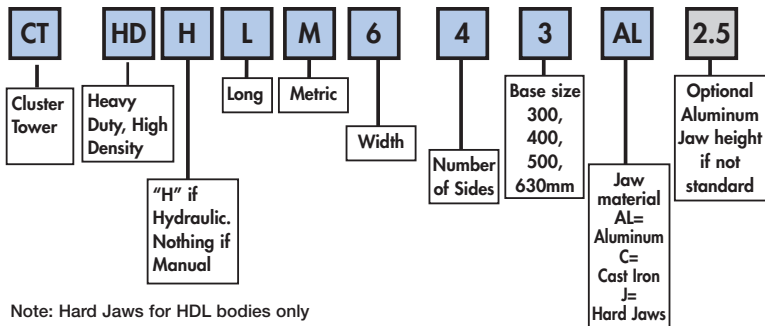

Note: Hard Jaws for HDL bodies only

THDM63AL (Manual 6" back-to-back vise, 300mm base with standard height aluminum jaws.)  
 THDHM66AL2.5 (Hydraulic 6" back-to-back vise, 630mm base with optional height aluminum jaws.)

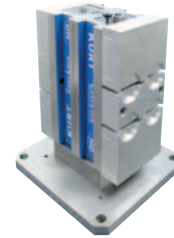

### HD Back-To-Back Vises Examples:

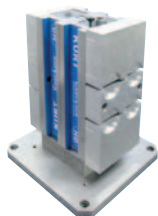
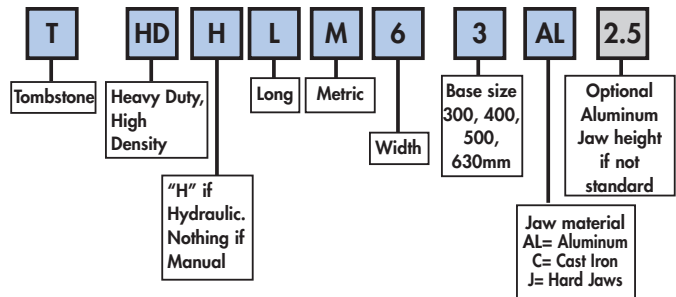

**Back-to-back mounting option.**  
 HD vises mount easily back-to-back, providing a new way to achieve a multiple clamping station tower. Contact factory for details. Estimated shipping weight: 88.9Kgs/196Lbs



### Fixture Plate (HD6ALP620-239) For HD Short Body

Ultra high density loads of small parts can be accommodated in a single setup by mounting various off-the-shelf clamping modules to this fixture plate.

To utilize this system's components, the movable and stationary vise jaws are removed and the fixture plate is positioned and then clamped by normal actuation of the vise.

**HD Vise design utilizes fewer working components. Faster changeovers. Fewer problems.**

