



WISE FEATURES

- » High clamp Force
- » Jaw design minimizes jaw lift
- » Easy center-line adjustment
- » Quick lash adjustment
- » Hex on both ends of screw, can be adjusted from either side
- » 52mm pattern spacing for mounting to industry standard zero-point systems
- » End-effector ready for automation integration
- » Max torque 45 foot pounds

Three new Precision Force 5-axis vises feature robot-ready design and Kurt AngLock® tech for maximum workholding strength and adaptability.

The new Precision Force 5-Axis MaxLock™ vise lineup features 3 models with 3 available jaw options. Robot-ready, with pull-stud mounting systems, Kurt PF-series vises offer user-friendly features including easy-to-adjust lash and 52mm spacing for automation-ready mounting systems to adapt to competitors' zero-point systems. New Quick Centerline Adjustment makes centerline adjustment fast and efficient and keeps parts perfectly positioned. Spring-loaded gibs keep parts square and are designed to maximize part-positioning repeatability through multiple cycles.

Kurt's PF420, PF440 and PF460 vises come with a standard 4-inch jaw width and jaw openings ranging from 2.625 to 6.625 inches. Patented AngLock® design pushes vise jaws down and forward for greater surface contact on parts—maximizing holding strength with less clamp force. Vises are available now for preorder at: kurtworkholding.com



Dovetail

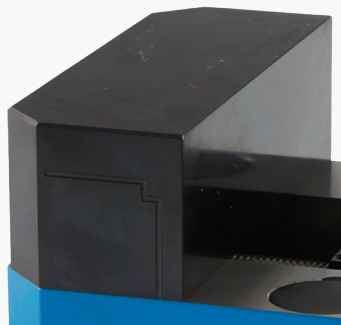

Machinable

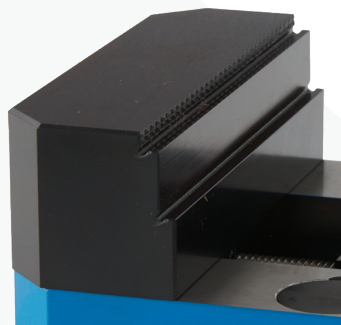

Serrated

JAW FEATURES

- » Movable jaw options: Machinable, Dovetail and Serrated
- » Jaws and nuts can be reversed for ID clamping
- » Nuts are gibbed to help with squareness

Precision Force MaxLock™ 5-Axis Vises

TECHNICAL SPECIFICATIONS

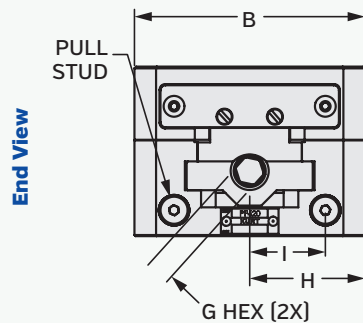
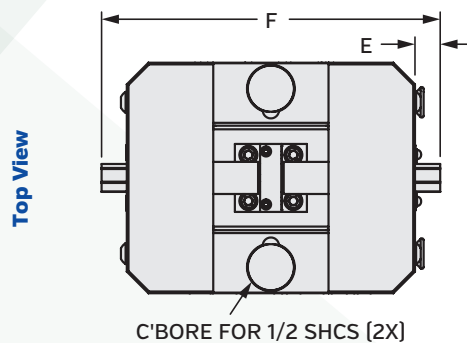
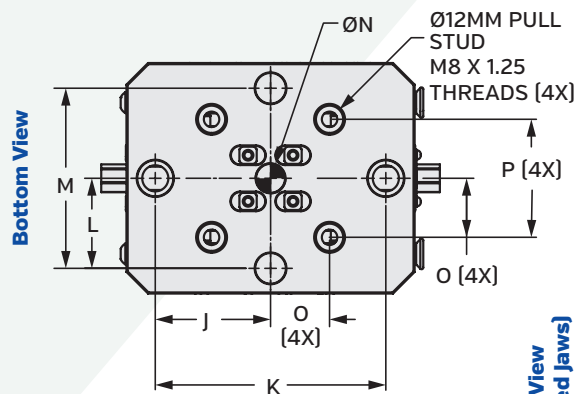

Torque (ft-lbs)	Clamp Force (lbs)
10	600
20	1,200
30	1,900
40	2,500
45	3,300

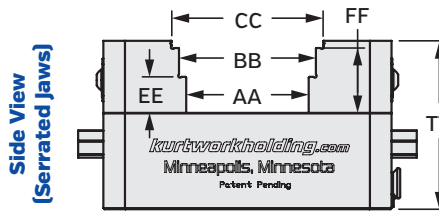

**Serrated models:
PF420S, PF440S, PF460S**

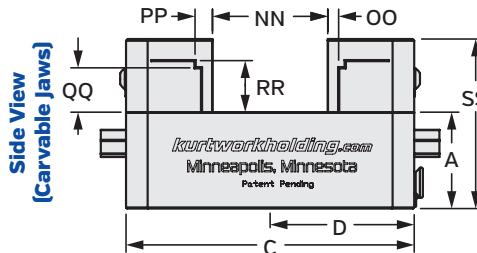

**Carvable models:
PF420C, PF440C, PF460C**

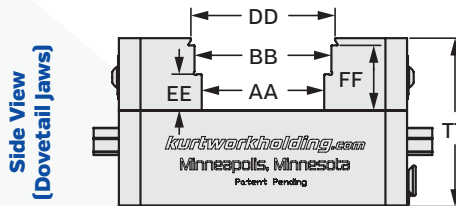

**Dovetail models:
PF420D, PF440D, PF460D**

	PF420	PF440	PF460
A	1.672	1.672	1.672
B	4.000	4.000	4.000
C	5.000	7.000	9.000
D	2.500	3.500	4.500
E	0.438	0.438	0.438
F	5.875	7.875	9.875
G	7/16	7/16	7/16
H	2.000	2.000	2.000
I	1.313	1.313	1.313
J	2.000	2.000	2.000
K	4.000	4.000	4.000
L	1.563	1.563	1.563
M	3.125	3.125	3.125
N	0.500	0.500	0.500
O	1.024	1.024	1.024
P	52mm	52mm	52mm
AA	2.125	4.125	6.125
BB	2.375	4.375	6.375
CC	2.625	4.625	6.625
DD	2.501	4.50	6.501
EE	0.625	0.625	0.625
FF	1.125	1.125	1.125
NN	2.000	4.000	6.000
OO	0.190	0.190	0.190
PP	0.303	0.303	0.303
QQ	0.770	0.770	0.770
RR	0.885	0.885	0.885
SS	2.942	2.942	2.942
TT	2.922	2.922	2.922

Precision Force Optional Riser Blocks

Designed for use with PF-Series Vises, each vise riser kit includes a base and all the accessories needed for installation.



HP420 Riser Kit



HP440 Riser Kit

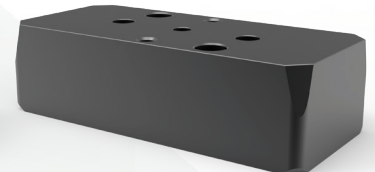

HP460 Riser Kit

kurtworkholding.com



Kurt Manufacturing // A Full-Service Multi-Divisional Manufacturer since 1946

9445 East River Road NW | Mpls, MN 55433 | workholding@kurt.com | 877.226.7823