



GRIPPER FEATURES

- » Automated finger changes in seconds with patent-pending pull stud design
- » Integrated electronic sensors ensure finger position and readiness
- » Light weight design: high-strength aluminum alloy
- » Hard-coat finish
- » Maximum clamping and unclamping force from double-acting oval piston
- » Self-centering wedge-type design for high force transmission and centric gripping
- » Small gripper size saves space in robotic cells
- » Optional aluminum or steel finger configurations

The new Kurt RV36 Robotic Arm Gripper saves space and money and improves efficiency with quick-change, customizable jaws and custom accessories.

The new RV36 Robotic Gripper is a two-finger parallel gripper featuring a revolutionary patent-pending design that allows automated finger/end-effector changes without changing the gripper body. Quick-change fingers are secured with pull studs and allow customers to save on gripper-body expenses and create greater part-holding flexibility by using multiple finger configurations with a single gripper body.

Loaded with features, the compact Kurt RV36 Gripper comes standard with integrated electronics featuring sensors that ensure fingers are in place and optional sensors to insure parts are in place and ready for production. High-strength aluminum alloy keeps gripper weight to a minimum while a hard-coat finish reduces wear and increases life in the field. Double-acting piston design gives the RV 36 Gripper maximum clamping and un-clamping force and carvable aluminum- or steel-finger options can be machined to work in a variety of applications. Additional finger sets are also sold separately.

Kurt RV 36 Grippers offer additional space- and money-saving features. The smaller gripper size allows easier storage where space is a premium and pull-stud automation saves money for customers with a quick-change finger system allowing multiple finger options for a single gripper body. The RV36 is the first robot gripper with the ability to automatically change gripper fingers and the ability to accommodate an endless variety of end-effector options.

Kurt RV36 Gripper

TECHNICAL SPECIFICATIONS

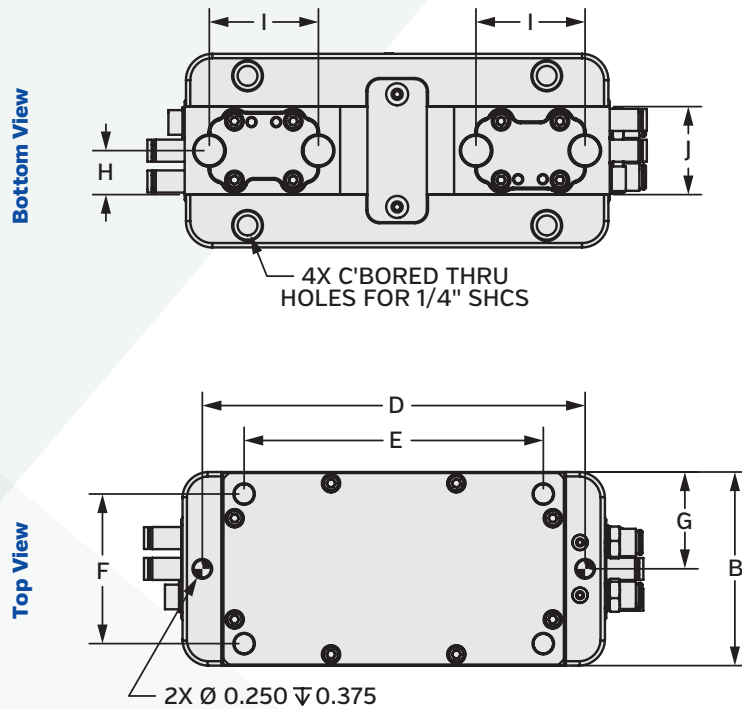

A	2.765
B	2.750
C	6.000
D	5.438
E	4.250
F	2.125
G	1.375
H	0.625
I	1.550
J	1.250
K	2.000
L	1.250
M	2.250
N	0.350
O	0.625
MAX OPEN AA	1.50
MIN OPEN BB	0.90

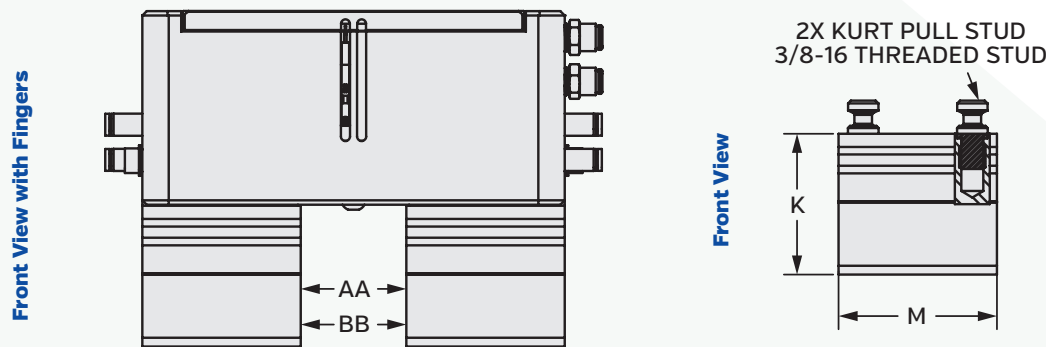
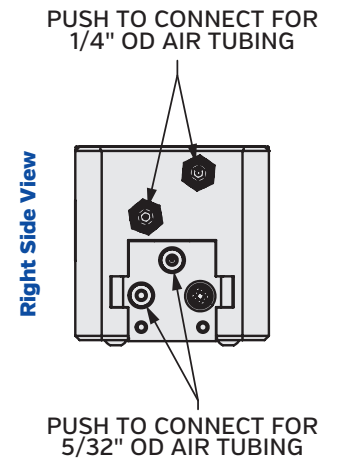
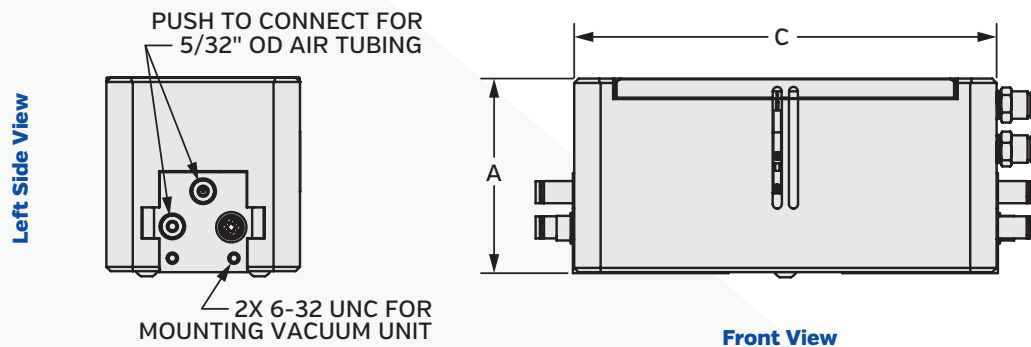

kurtworkholding.com



Kurt Manufacturing // A Full-Service Multi-Divisional Manufacturer since 1946

9445 East River Road NW | Mpls, MN 55433 | workholding@kurt.com | 877.226.7823