



KURT WORKHOLDING SYSTEMS

NEW SOLUTIONS FROM KURT



> NEW Precision Force Vise



> NEW Kurt RV36 Gripper



> NEW Pyramid 45°
mounting platform



> NEW Hydraulic Pump
Components for
Automation

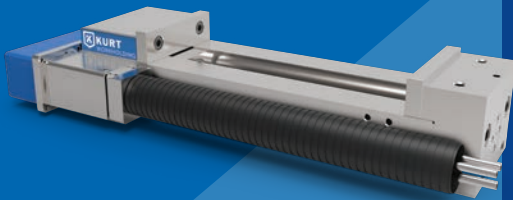

> NEW Air Vise - Air Powered
Vise for Automation

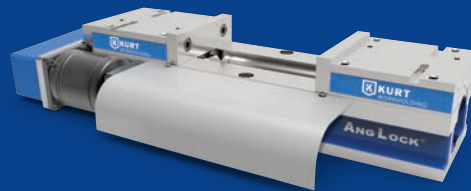

> NEW Servo Vise
For Automation



> NEW Responsive Website

Automation

Pages 4-7

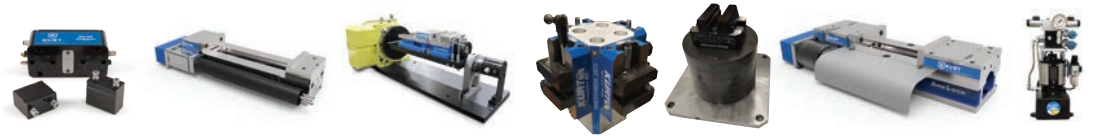

5 Axis Products

Pages 8-15



Single Station Visés

Pages 16-31



Double Station Visés

Pages 32-37



Cluster Tower® & Tombstones

Pages 38-51

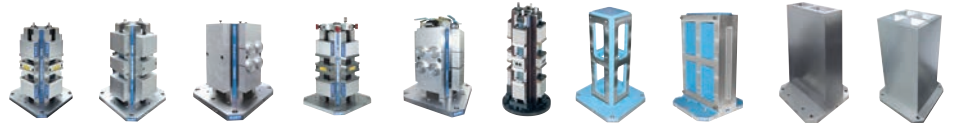

Specialty Visés

Pages 52-61



Modular Visés

Pages 62-67

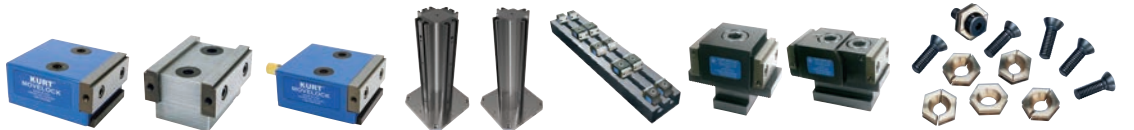

Quick Change Locators

Pages 68-70

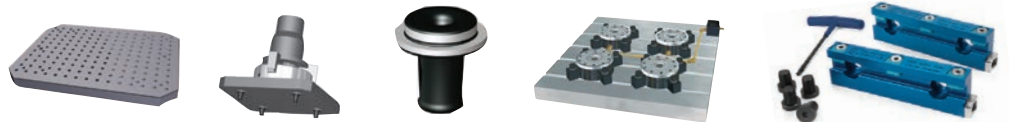

Accessories

Pages 71-79



Vise Mounting Options

Page 80



Power Drawbar

Pages 81



Power Drawbar Parts

Page 91

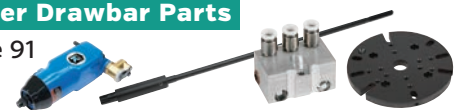

Engineered Systems

Pages 82-87



Gaging

Pages 88-89



Parts Kits

Pages 90-91



Kurt RV36 Gripper

The new Kurt RV36 Robotic Arm Gripper saves space and money and improves efficiency with quick-change, customizable jaws and custom accessories.

- Automated finger changes in seconds with patent-pending pull stud design
- Integrated electronic sensors ensure finger position and readiness
- Light weight design: high-strength aluminum alloy
- Maximum clamping and unclamping force from double-acting oval piston
- Self-centering wedge-type design for high force transmission and centric gripping
- Small gripper size saves space in robotic cells

See pages 6-7 for complete details



Precision Force (PF) Vises

- High clamp force
- Jaw design minimizes jaw lift
- Easy centerline adjustment
- Quick lash adjustment
- Hex on both ends of screw, can be adjusted from either side
- 52mm pattern spacings for mounting to industry standard zero-point systems
- End effector ready for automation integration

See pages 8-9 for complete details



Air Vise - Air Powered Vise for Automation

- Air powered motorized clamping provides consistent preset force and can be set to stop precisely on location
- Works great in automated systems and with Robotic workpiece handling
- Helps provide consistent clamping in unattended CNC operation
- Can be equipped with most Kurt vise models
- Air motor can be positioned under or on the side of the vise
- Operates on 20-100 PSI and requires air/oil mist
- Movable jaw can move through the entire stroke of the vise
- Air motor advantages include clean and easy pneumatic circuit hookup



Servo Vise - For Automation

- Variable speed servo and position programmable
- Servo powered vise with Allen Bradley 570 watt Servo Motor
- Capable of handling loads up to 80 ft-lbs torque [Max torque with most Kurt 6 inch vises]
- Encoder
- Gear Drive and Gear Box Assembly Included
- Ethernet Cable [8 Conductors] Included
- Optional Ethernet/IP Servo Drive and cable sold separately

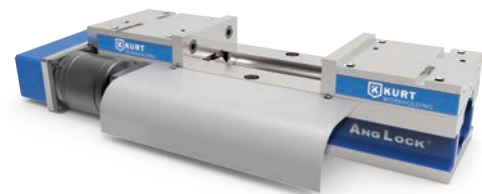

Specialty Vises & Custom Engineered Workholding

Your ideas aren't off-the-shelf. Why should your workholding be? When you want the best workholding solutions for your specific needs, let Kurt custom-build them for you. Then, get ready to experience increased throughput and lower costs.

See pages 52-61 for complete for Specialty Vises

See pages 82-83 for complete for Custom Engineered Vises

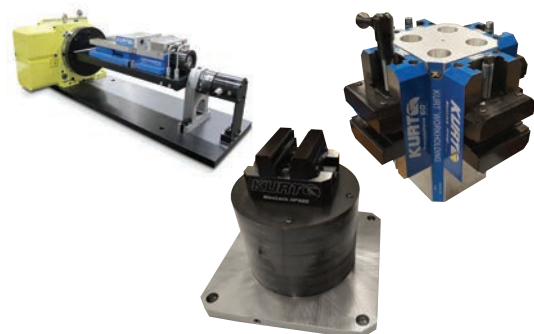

Pyramid 45° mounting platform

- 45-degree Pyramid design provides maximum access to all machined surfaces and allows for enhanced spindle and cutting tool clearance.
- Pyramid platform configuration accommodates 11 different Kurt vises including these models: HP series, PF series, SCMX series, and DT series vises. Jaw options available from Carvable, Dovetail and Serrated.
- Pyramid platform is constructed of 7075 anodized aluminum and has a 12" diameter base.
- Fits a wide variety of 5 axis CNC machines with predrilled holes for easy mounting to most machine tables, pallets or wide variety of sub plates.

See page 14 for complete details



Pyramid 45° mounting platform with zero-point dock system

- 45-degree Pyramid design interfaces easily with DockLock mounting system for quick, high precision changovers.

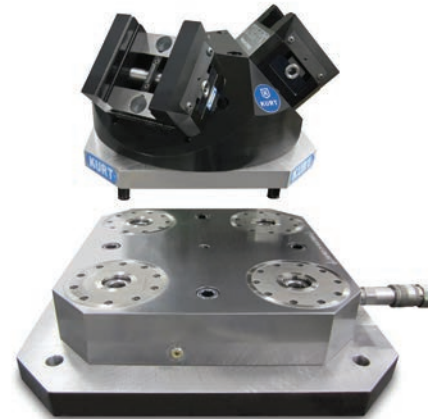

Hydraulic Pump Components for Automation

The Kurt automation pump system is custom configurable to match customer applications. It features fully integrated design for plug & play operation. Just add the appropriate connectors that fit your specific CNC controller or other I/O device.

See page 76 for complete details



Automation Inspection Gaging Systems

From automotive manufacturers to tier-one subcontractors who manufacture components and assemblies, Kurt clients span most areas of precision manufacturing. Kurt Gaging also provides SPC software/ hardware solutions and probes to OEM gaging/fixture makers and robotic system integrators.

See page 89 for complete details

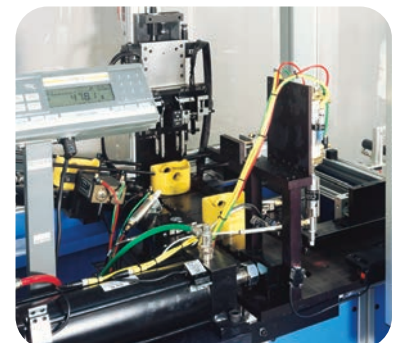

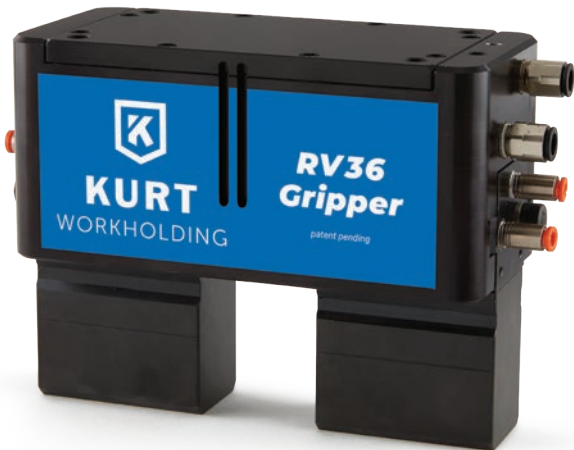

Kurt RV36 Gripper

The new Kurt RV36 Robotic Arm Gripper saves space and money and improves efficiency with quick-change, customizable jaws and custom accessories.

The new RV36 Robotic Gripper is a two-finger parallel gripper featuring a revolutionary patent-pending design that allows automated finger/end-effector changes without changing the gripper body. Quick-change fingers are secured with pull studs and allow customers to save on gripper-body expenses and create greater part-holding flexibility by using multiple finger configurations with a single gripper body.

Loaded with features, the compact Kurt RV36 Gripper comes standard with integrated electronics featuring sensors that ensure fingers are in place and optional sensors to insure parts are in place and ready for production. High-strength aluminum alloy keeps gripper weight to a minimum while a hard-coat finish reduces wear and increases life in the field. Double-acting piston design gives the RV 36 Gripper maximum clamping and un-clamping force and carvable aluminum- or steel-finger options can be machined to work in a variety of applications. Additional finger sets are also sold separately.

Kurt RV 36 Grippers offer additional space- and money-saving features. The smaller gripper size allows easier storage where space is a premium and pull-stud automation saves money for customers with a quick-change finger system allowing multiple finger options for a single gripper body. The RV36 is the first robot gripper with the ability to automatically change gripper fingers and the ability to accommodate an endless variety of end-effector options.

Gripper Features

- Automated finger changes in seconds with patent-pending pull stud design
- Integrated electronic sensors ensure finger position and readiness
- Light weight design: high-strength aluminum alloy
- Hard-coat finish
- Maximum clamping and unclamping force from double-acting oval piston
- Self-centering wedge-type design for high force transmission and centric gripping
- Small gripper size saves space in robotic cells
- Optional aluminum or steel finger configurations



RV36 Gripper without Fingers

RV36A Gripper with Aluminum Fingers

RV36S Gripper with Steel Fingers

**RV36-388A-SA Aluminum Gripper Finger Assembly
Complete with Pull Studs and Magnet Installed (single)**

**RV36-388S-SA Steel Gripper Finger Assembly
Complete with Pull Studs and Magnet Installed (single)**

Kurt RV36 Gripper

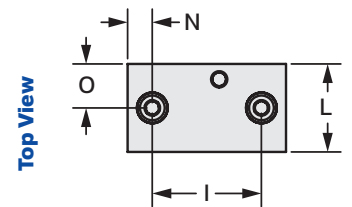
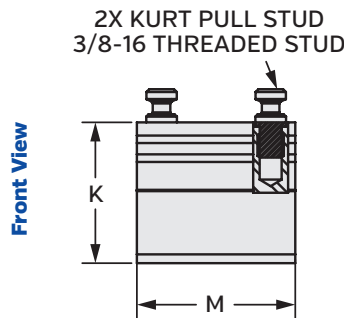
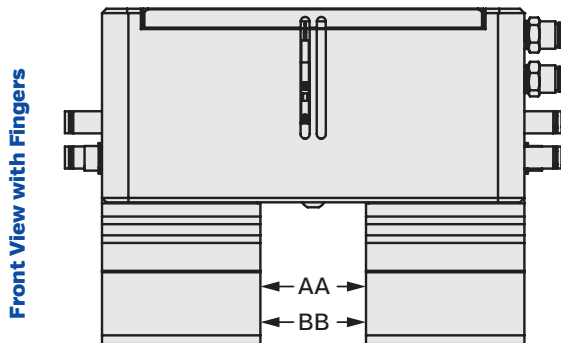
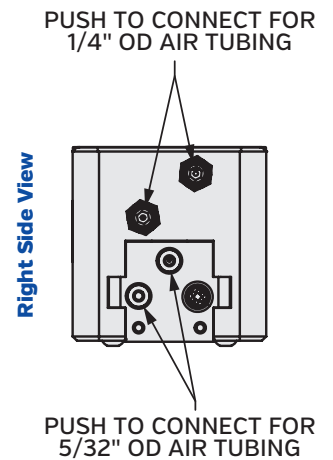
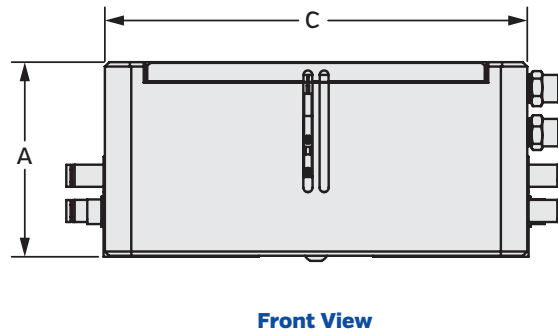
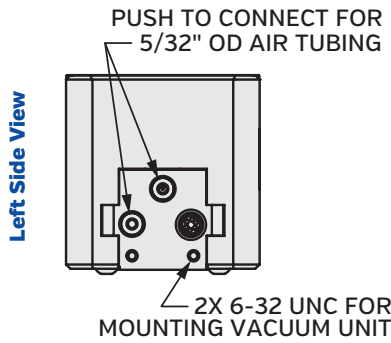
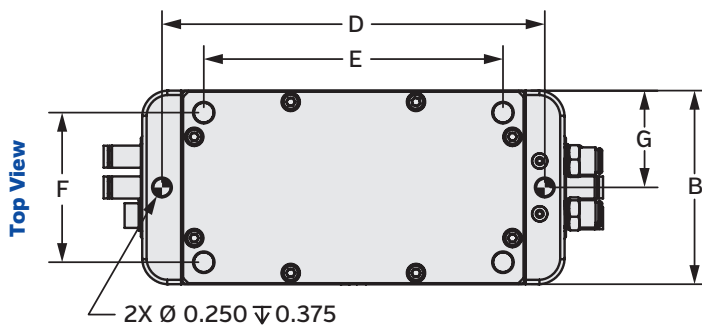
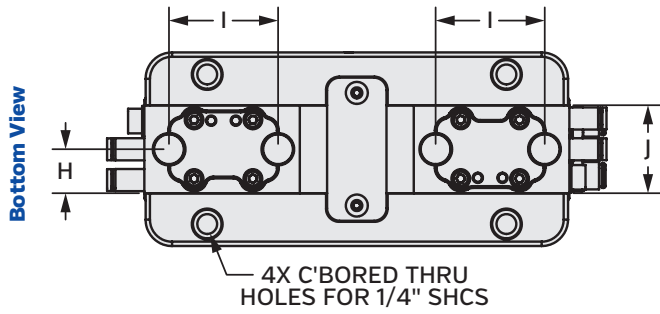

Dimensional Data	
A	2.765
B	2.750
C	6.000
D	5.438
E	4.250
F	2.125
G	1.375
H	0.625
I	1.550
J	1.250
K	2.000
L	1.250
M	2.250
N	0.350
O	0.625
MAX OPEN AA	1.50
MIN OPEN BB	0.90

Gripper weight: 5.6 Lbs.
Aluminum Finger weight: 0.55 Lbs.
Steel Finger weight: 1.3 Lbs.



Precision Force (PF) Vises

- High clamp force
- Jaw design minimizes jaw lift
- Easy centerline adjustment
- Quick lash adjustment
- Hex on both ends of screw, can be adjusted from either side
- 52mm pattern spacings for mounting to industry standard zero-point systems
- End effector ready for automation integration
- Movable jaw options: Carvable, Dovetail and Serrated
- Jaws and nuts can be reversed for ID clamping
- Jaws are gibbed to help with squareness
- Max torque 45 foot pounds.

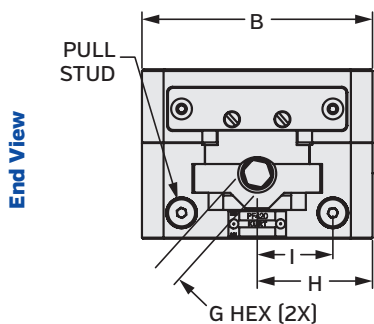
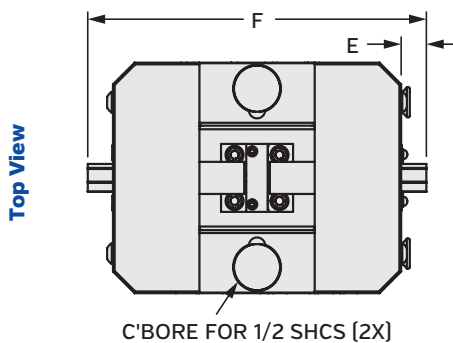
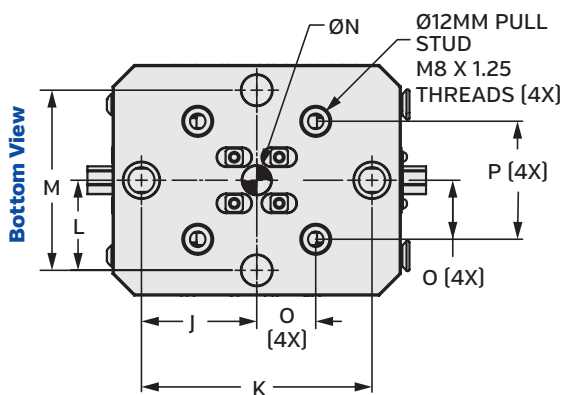

Side View (Serrated jaws)

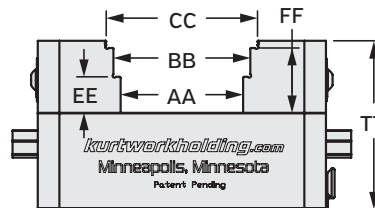

Serrated models:
PF420S, PF440S, PF460S

Side View (Carvable jaws)

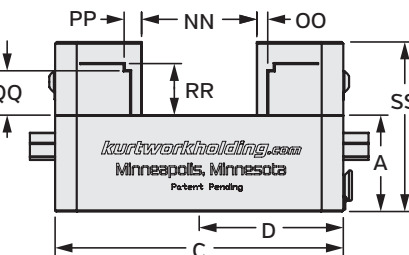

Carvable models:
PF420C, PF440C, PF460C

Side View (Dovetail jaws)

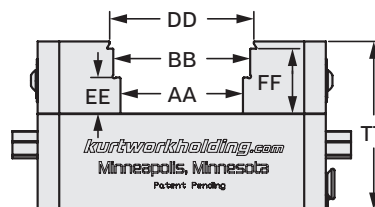

Dovetail models:
PF420D, PF440D, PF460D

Torque (ft-lbs)	Clamp Force (lbs)	PF420	PF440	PF460	
10	600	A	1.672	1.672	1.672
20	1,200	B	4.000	4.000	4.000
30	1,900	C	5.000	7.000	9.000
40	2,500	D	2.500	3.500	4.500
45	3,300	E	0.438	0.438	0.438

F	5.875	7.875	9.875
G	7/16	7/16	7/16
H	2.000	2.000	2.000
I	1.313	1.313	1.313
J	2.000	2.000	2.000
K	4.000	4.000	4.000
L	1.563	1.563	1.563
M	3.125	3.125	3.125
N	0.500	0.500	0.500
O	1.024	1.024	1.024
P	52MM	52MM	52MM
AA	2.125	4.125	6.125
BB	2.375	4.375	6.375
CC	2.625	4.625	6.625
DD	2.501	4.501	6.501
EE	0.625	0.625	0.625
FF	1.125	1.125	1.125
NN	2.000	4.000	6.000
OO	0.190	0.190	0.190
PP	0.303	0.303	0.303
QQ	0.770	0.770	0.770
RR	0.885	0.885	0.885
SS	2.942	2.942	2.942
TT	2.922	2.922	2.922
Weight	11 Lbs	14 Lbs	17 Lbs

Precision Force Optional Riser Blocks

Designed for use with PF-Series Vises, each vise riser kit includes a base and all the accessories needed for installation.



HP420-RISERKIT



HP440-RISERKIT



HP460-RISERKIT

Jaw Features

- Movable jaw options: Machinable, Dovetail and Serrated
- Jaws and nuts can be reversed for ID clamping
- Nuts are gibbed to help with squareness

	HP420-RISERKIT	HP440-RISERKIT	HP460-RISERKIT
A	5.000	7.000	9.000
J	4.000	4.000	4.000
K	2.500	2.500	2.500
L	Ø 0.625	Ø 0.625	Ø 0.625
M	Ø 1.000	Ø 1.000	Ø 1.000
P	1/2-13 SHCS	1/2-13 SHCS	1/2-13 SHCS
Q	1/2-13 SHCS	1/2-13 SHCS	1/2-13 SHCS
R	3.125	3.125	3.125
S	4.500	4.500	4.500
T	2.767	2.767	2.767
U	3.549	3.549	3.549
V	4.000	4.000	4.000
W	Ø 0.625	Ø 0.625	Ø 0.625
X	1/4-20 SHCS	1/4-20 SHCS	1/4-20 SHCS
Weight	6 lbs	8 lbs	11 lbs

Replacement Jaws		
Part Number	Description	Weight
PF420-2S	Serrated Jaw	1.6 lbs
PF420-2C	Carvable Jaw	1.8 lbs
PF420-2D	Dovetail Jaw	1.6 lbs

Sold Individually

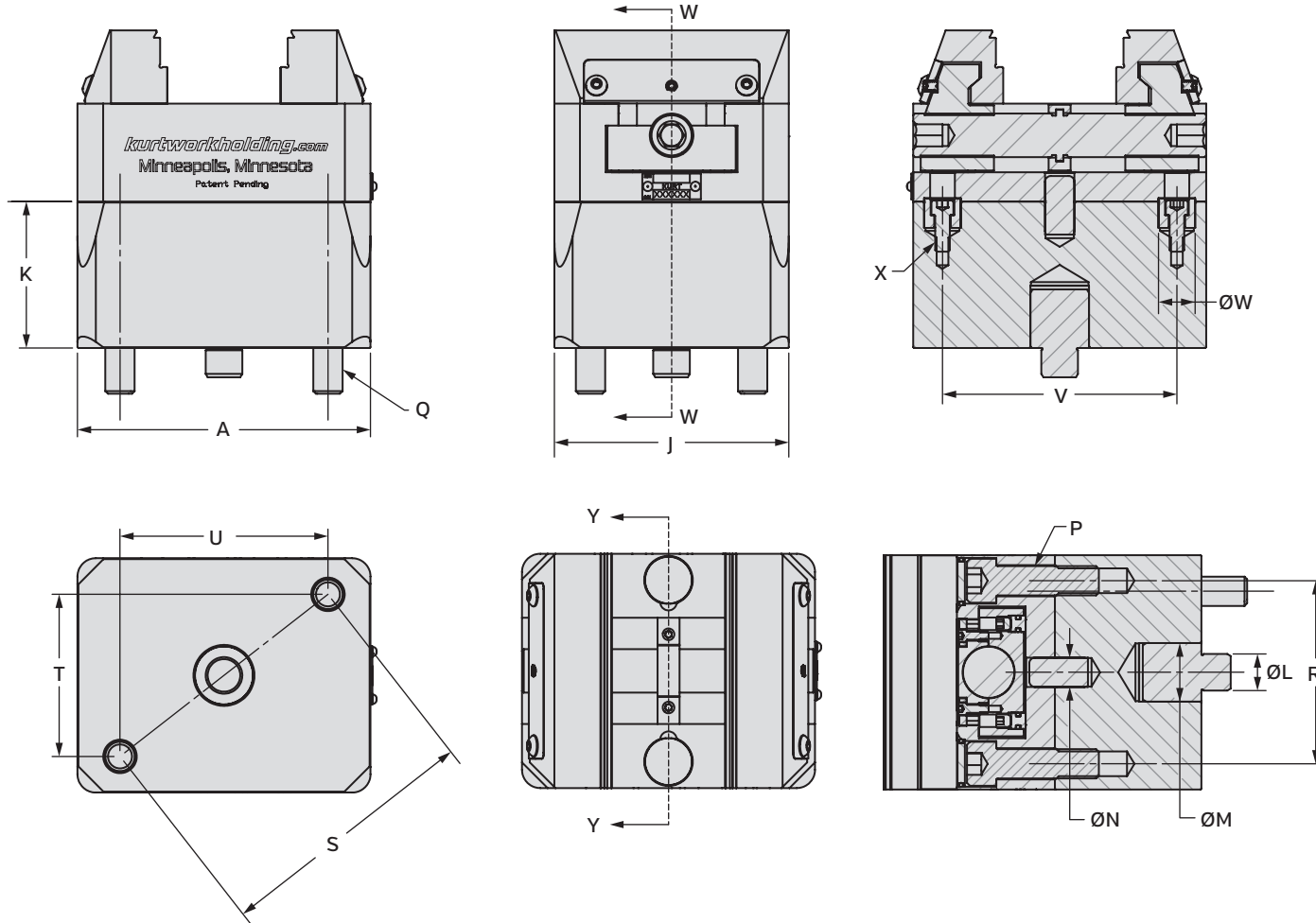



DoveLock™ Dovetail 5 Axis Vise

- DoveLock™ dovetail vise for 4 and 5 axis CNC machining with access to five sides of the workpiece.
- Manufactured from pre-hardened 4140 steel, the DoveLock maintains part rigidity and minimizes deflection or clamp creep when under high machining pressure.
- Reversible models allow for a wide range of dovetail widths.
- High clamping screw location reduces deflection.
- Movable jaw slide is retained within the stationary jaw and creates more anti-deflection control.
- Embedded locating pin keeps part location accurate when applying side load pressure.
- Models available: Reversible jaw models DTR20 and DTR10.
- Mounting base has pre-configured hole pattern to fit most machines.
- Easy part prep requires only 1/8" of material to hold workpiece in place.
- Movable and stationary jaws are matched pairs.
- Lifetime Iron Clad Warranty.

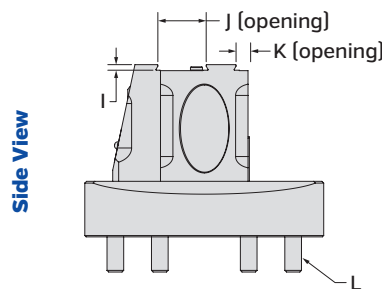
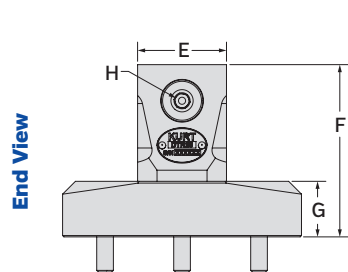
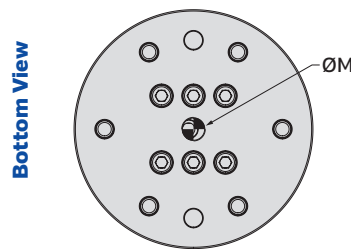
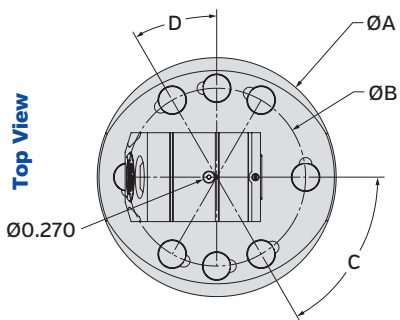

	DTR20	DTR10
ØA	5.38	2.69
ØB	4.00	2.00
C	60°	60°
D	30°	30°
E	2.00	1.00
F	3.875	2.00
G	1.25	0.625
H	1/2-13 BHSCS	1/4-20 BHSCS
I	0.125	0.125
J [opening]	1.09 - 1.65	0.52 - 0.80
K [opening]	0.33 - 0.88	0.29 - 0.57
L	3/8-16 SHCS	10-32 SHCS
ØM [slip fit dowel]	0.500	0.250
Est. Weight	11 Lbs	1.5 Lbs

Clamp Force DTR20	
Inch Pounds	Pounds of Force
80	1,000
160	2,000
240	3,000
320	4,000



Dovetail Cutter
Model: DT20-363

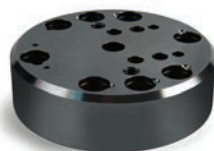

Optional Riser Base
for DT20 vise only
Model: DT20-1

DT20-1 Riser Base	
Riser Height	1.250"
Riser Diameter	4.47"
Weight	5 Lbs.



Additional pallet options available-
contact factory for details

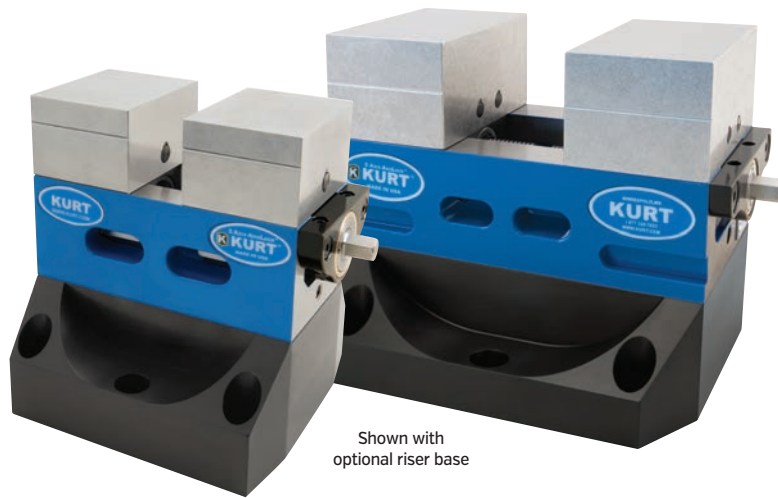

Shown with optional riser base



Optional riser bases:
SCM250-RISERKIT SCM425-RISERKIT



Optional mounting pallets - contact factory for options

MaxLock™ 5 Axis Self-Centering Vise

- Vise for five axis machining.
- ±0.0002" repeatability.
- Adjustable Center Line.
- Machinable Jaws – choice of aluminum or steel.
- The customer will machine in a step for higher accuracy eliminating the need for parallels.
- Holds up to a 6-1/2" long parts with model SCM425.
- Clamp both OD and ID.
- Kurt AngLock design pulls the part down.
- 2-1/2" & 4" jaw widths.
- Tall jaws for increased spindle clearance.
- Jaws are reversible.
- Flexible mounting options.
- Hex keys required for jaw removal:
SCM250: 5/64", 3/32"
SCM425: 3/32", 1/8"

Dimensional Data	SCM250		SCM250		SCM425		SCM425		Jaw Kits (Includes Two Jaws)								
	SCM425	SCM425AL	SCM250	SCM250AL	Ft. Lbs	Lbs Force	Ft. Lbs	Lbs Force	Part Number	Length	Width	Height	Weight				
A	2.313	2.000	10	350	10	500	SCM250AL-JAWKIT Aluminum Jaw Kit							2.00	2.50	1.50	2
B	4.000	2.500	20	750	20	1,000	SCM425AL-JAWKIT Aluminum Jaw Kit							2.75	4.00	2.25	5
C	8.000	5.000	30	1,300	30	1,500	SCM250C-JAWKIT Steel Jaw Kit							2.00	2.50	1.50	4
D	4.000	2.500	40	1,800	40	2,000	SCM425C-JAWKIT Steel Jaw Kit							2.75	4.00	2.25	12
E	0.69	0.69			50	2,500											
F	1.12	1.11			60	3,000											
G	3/8	5/16															
H	2.25	1.50															
J	2.75	2.00															
K	9.12	6.11															
L	1.625	1.344															
M	1.125	0.940															
N	0.000	0.000															
P	2.500	1.000															
Q	0.531 Ø	0.406 Ø															
S	1.000	1.000															
T	1.250	-															
U1	3.000	-															
U2	3.000	2.000															
U3	1.500	-															
U4	1.500	-															
V	0.625	0.375															
W	0.688	0.500															
X	0.375	-															
Y	0.500	-															
Z	1.750	-															
AA	2.500	2.313															
BB	7.063	5.813															
CC	7.000	4.750															
DD	6.000	4.000															
EE	6.000	4.000															
FF	3.000	2.000															
GG	1/2	3/8															
Est. Weight	30 Lbs	10 Lbs															

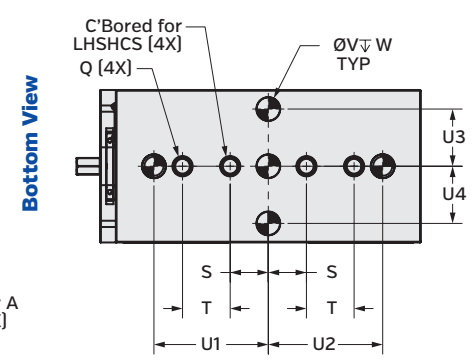
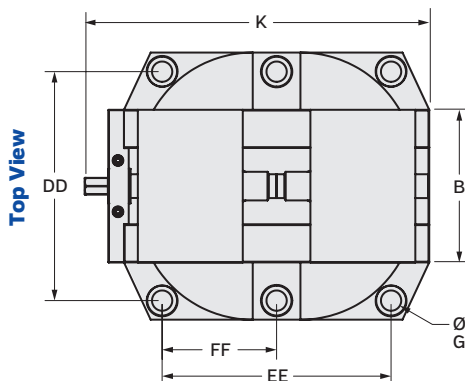
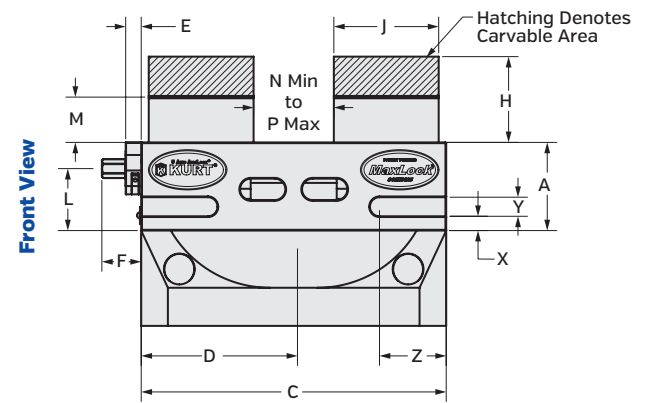
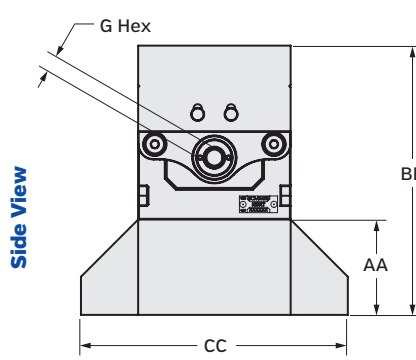

Riser Not Shown in This View



MaxLock™ MX350 Multi-Axis AngLock® Vise

- Kurt AngLock Design pulls the part down.
- Pull Type feature decreases stationary deflection.
- 0.625" stroke – Allows for wider range of clamping before having to change setup.
- Modular Design – Mounts on two inch grid patterns when removed from the riser and "T" slots or center hole grids 100 mm and under.
- When mounted in a two inch grid the vise comes with locator bolts for quick alignment.
- When mounted on the risers, precision 5/8 holes have been added so Kurt sine keys can be used for quick alignment.
- Auxiliary clamping slots – allows the customer more flexibility in mounting the vise.
- The customer will finish machine the horizontal surface of the jaw plate for higher accuracy, eliminating the need for parallels.
- Machinable semi-hard steel jaws available in 3 lengths.
- The screw is easily manufactured and changed, by the customer, to allow a broad range of part sizes.
- Maximum of 40 Ft. Lbs. provides up to 7,000 Lbs. clamping force.
- Weight: 31 Lbs.
- Patented

Screw Selection Chart

Part Number	Screw Length	Minimum Jaw Opening	Maximum Jaw Opening
*MX350-5-8	8.00	0.15	3.5
MX350-5-12	12.00	3.5	7.5
MX350-5-18	18.00	7.5	11.5
MX350-5-24	24.00	11.5	15.5

*Comes standard with MX350-5-8 screw

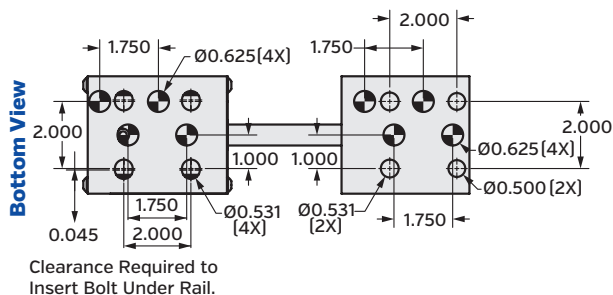
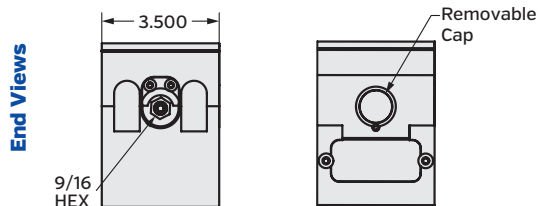
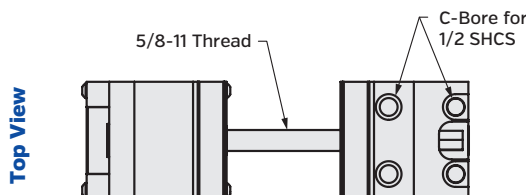
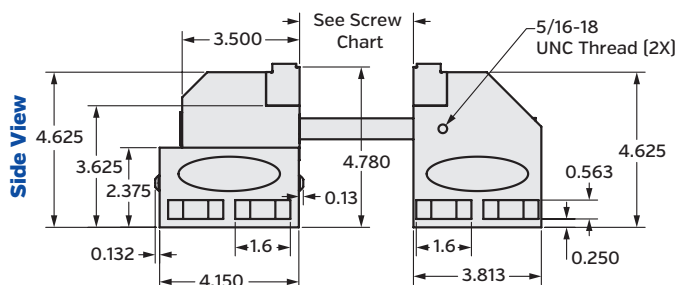

Optional Risers Part No MX350RL and MX350RS

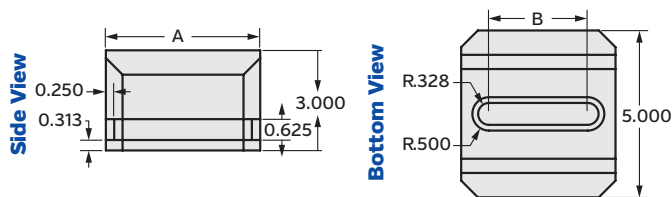

Part Number	A	B
MX350RS	4.625	2.95
MX350RL	5.650	3.97

MX350-236 Jawplate

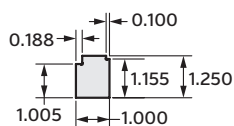

Machinable Jaw Semi-Hard Steel

Part Number	A	B
MX350-235-35	0.230	3.50
MX350-235-45	0.730	4.50
MX350-235-55	1.230	5.50

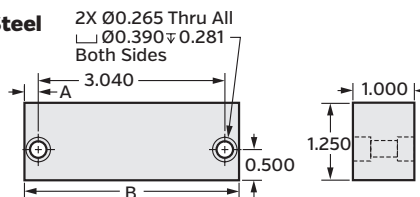

Options:

- MX350-236 Double Step Jawplate
- MX350-236-1 Double Step Jawplate w/CBN Coating



BP8 5 Axis Adapter Plates

- Designed to cover a wide range of vises and a wide range of tables.
- The mounting slots are designed to be covered up when a vise is mounted to keep clear of chips.
- An easier way to mount Kurt 5 axis vises to a machine table.
- Comes complete with Base Plate, Cover Plate, and Cover Plate Screws.
- Weighs 13lbs.

Model	Locating Spud Ø	Locating Spud	Mounting Bolts
DT20	0.5000	BP8-277-2	3/8-16 X 1.375 LG S.H.C.S.
DTR20	0.5000	BP8-277-2	3/8-16 X 1.375 LG S.H.C.S.
PF420	0.5000	BP8-277-2	1/2-13 X 1.875 LG S.H.C.S.
PF440	0.5000	BP8-277-2	1/2-13 X 1.875 LG S.H.C.S.
PF460	0.5000	BP8-277-2	1/2-13 X 1.875 LG S.H.C.S.
SCMX250	0.3750	BP8-277-1	3/8-16 X 1.25 LG L.H.S.H.C.S.
SCMX425	0.6250	BP8-277-3	1/2-13 X 1.50 LG L.H.S.H.C.S.

Item No.	Part Number	Qty	Description
1	BP8-244 [5 Axis 8.0 Base Plate]	1	8 Inch Round Base Plate
2	BP8-53 [5 Axis 8.0 Base Plate Cover]	1	Base Plate Cover
3	03-0133	4	SBHCS 1/4-20 X 1/2 LG

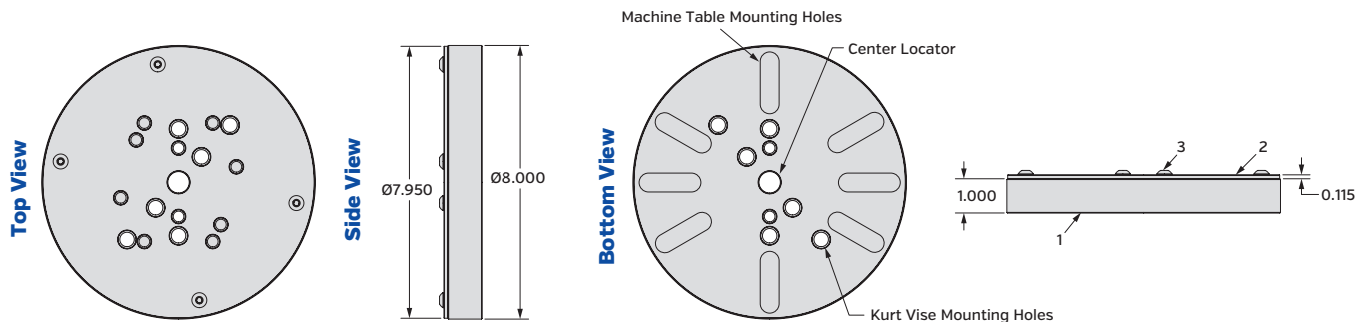

BP8 works With These Vises

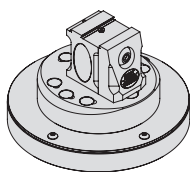

DTR20

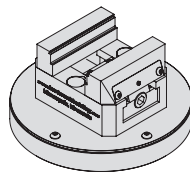

**PF420
PF440
PF460**

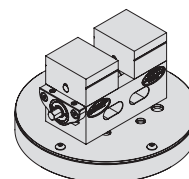

SCMX250

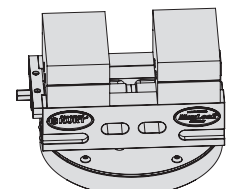

SCMX425



Pyramid 45° mounting platform

- 45-degree Pyramid design provides maximum access to all machined surfaces and allows for enhanced spindle and cutting tool clearance.
- Pyramid platform configuration accommodates 11 different Kurt vises including these models: HP series, PF series, SCMX series, and DT series vises. Jaw options available from Carvable, Dovetail and Serrated.
- Pyramid platform is constructed of 7075 anodized aluminum and has a 12" diameter base.
- Fits a wide variety of 5 axis CNC machines with predrilled holes for easy mounting to most machine tables, pallets or wide variety of sub plates.
- Weight: 35 lbs.

Side View

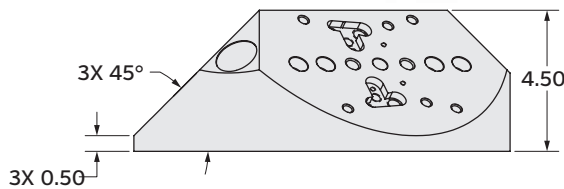

Top View

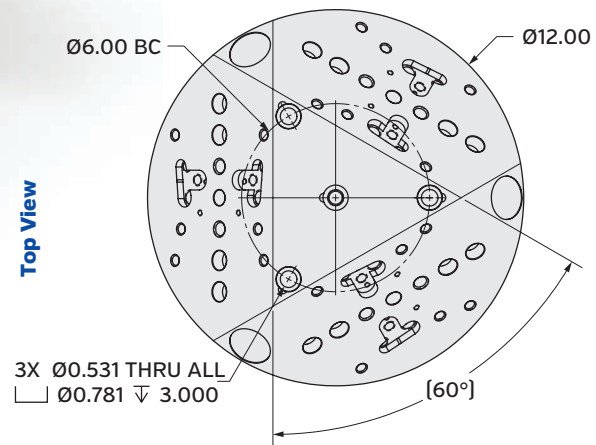

Mini ToolBlox™

- Designed to fit a wide range of machine tables.
- Easily handles a variety of KURT 5 axis vises and MiniLock systems.
- Machined from solid aluminum.
- Weighs only 22lbs. and easily handled by today's CNC machines.
- Mounting hardware for Matsuura Machines included.

Top View

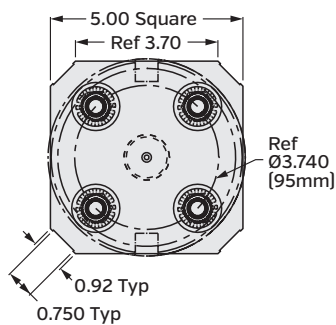

Detail A

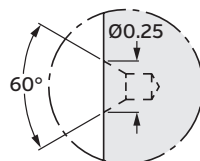

Side View

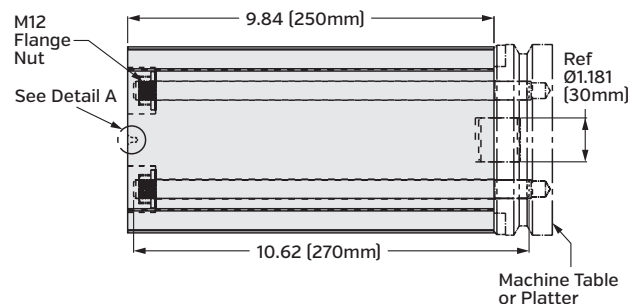

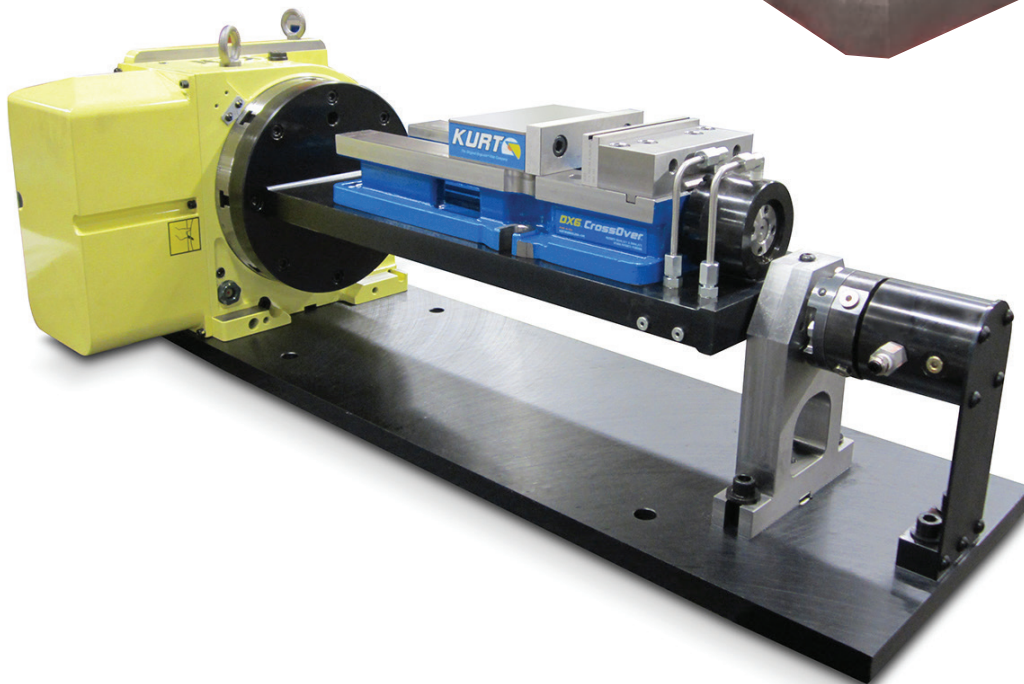
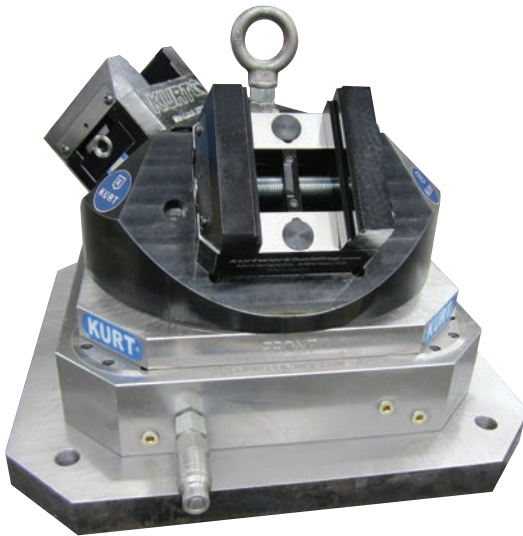
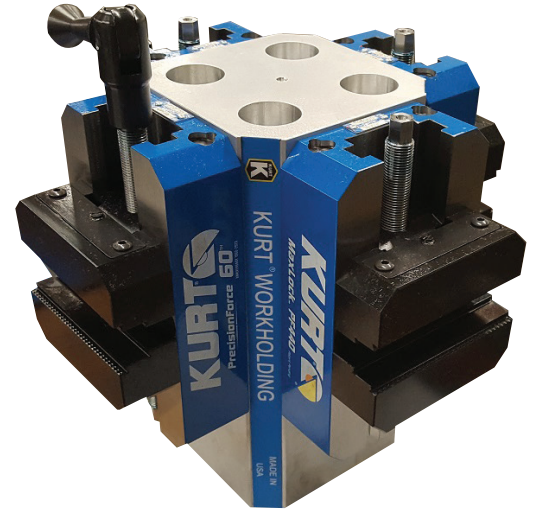

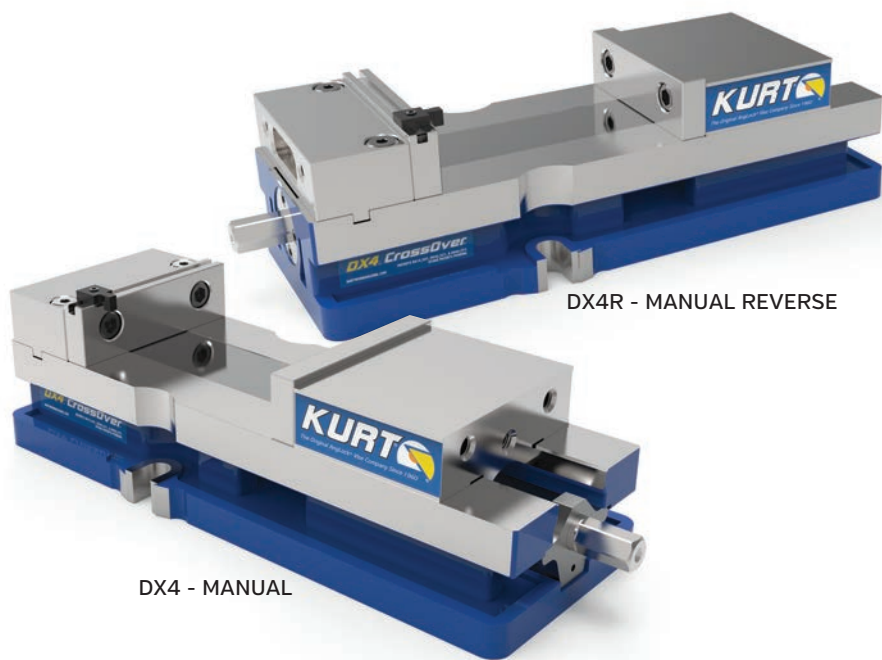

Kurt® DX4® CrossOver® Vise

Introducing the Kurt DX4 CrossOver Vise

The evolutionary DX4® CrossOver® Vise combines all the great features of the world-renowned KURT D40 and 3400V vises, along with new state-of-the-art workholding features. DX4 CrossOver achieves new levels in precision and performance where flatness and parallelism are important and is a better vise than our own D40 in every way we measure a vise. With KURT'S MADE IN AMERICA commitment, the DX4 CrossOver is destined to become the go-to-vise for today's machining applications.

Metric versions available - call factory.

Side View

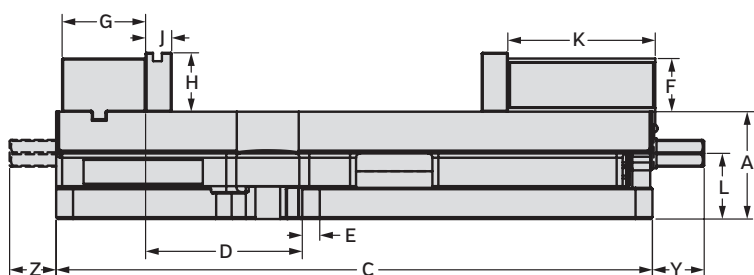

End View

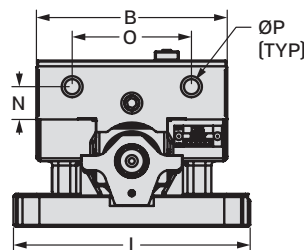

Bottom View

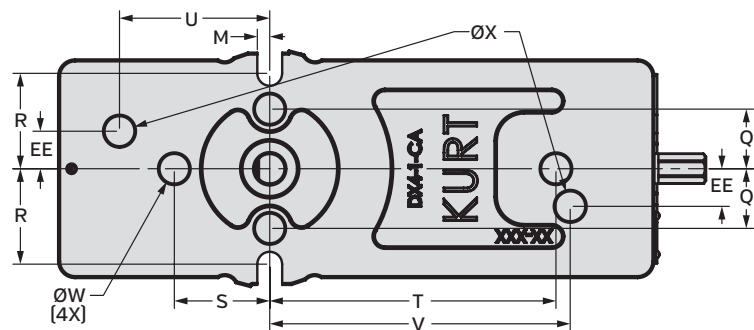

Vise Mounting Options - See page 80

Jaw Openings

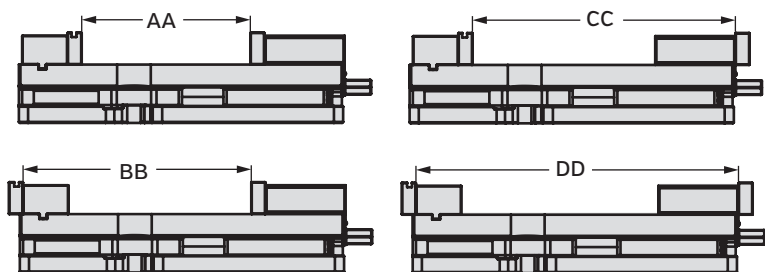

Dimensional Data

	DX4/DX4R
A	2.250
B	4.000
C	12.500
D	3.285
E	0.365
F	1.115
G	1.750
H	1.235
I	4.962
J	0.547
K	3.090
L	1.387
M	0.260
N	0.687
O	2.500
P	3/8-16
Q	1.250
R	2.000
S	2.000
T	6.000
U	80MM
V	160MM
W	0.625
X	16 mm
Y	1.084
Z	0.976
AA	6.500
BB	8.797
CC	10.137
DD	12.434
EE	20MM
Weight	30 lbs

Clamping Force Lbs.	
Ft. Lbs	Lbs Force
20	1,900
30	3,065
40	4,315
50	5,365
60	6,455
70	7,440

DX4® CrossOver® Features:

1. DX4 CrossOver vise is a combination of AngLock®, Pull-Type and 2 top bolt FEA designed stationary jaw. When combined they create an ultra unique strategy for a better vise:
 - AngLock® design reduces jaw lift
 - Pull-type design reduces stress on body during clamping
2. Hardened vise bed/jaw plates
3. Semi-hard steel screw
4. 80,000 psi ductile iron body, nut and movable jaw
5. 6.5" opening
6. New wider 2 bolt stationary design fastens from the top
7. Bolts & locates on 40mm, 50mm and 2" grid patterns
8. Accepts sine keys for alignment (not included)
9. Chip evacuation straight through the body
10. Screw support held in place with snap rings
11. Groove Lock® jaw plate and workstop included
12. New brush seal nut design makes it easier to replace
13. Includes chip guard
14. Powder coat paint is long lasting and durable
15. Matching of the bed heights or keyway to stationary jaw (additional cost)
16. Lifetime Iron Clad Warranty

DX4 CrossOver features comparison to D40 Vise:

17. DX4 is a replacement vise to D40 vise
18. Larger opening [6.5" versus 3-7/8"]
19. Same bed height as D40
20. Narrower body style than D40 and allows more vises on machine table
21. Updated proven bearing pack shared with the 3400 series
22. Same distance from the keyway to stationary as D40

DX4 CrossOver Vise Models available:

- DX4 Manual
- DX4R Manual Reverse

New stationary jaw

FEA designed 2 bolt stationary jaw reduces deflection

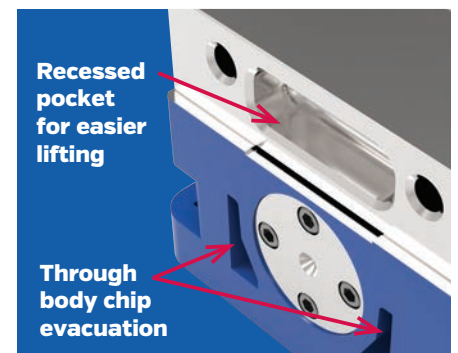
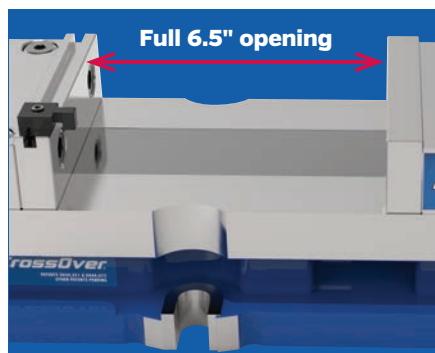
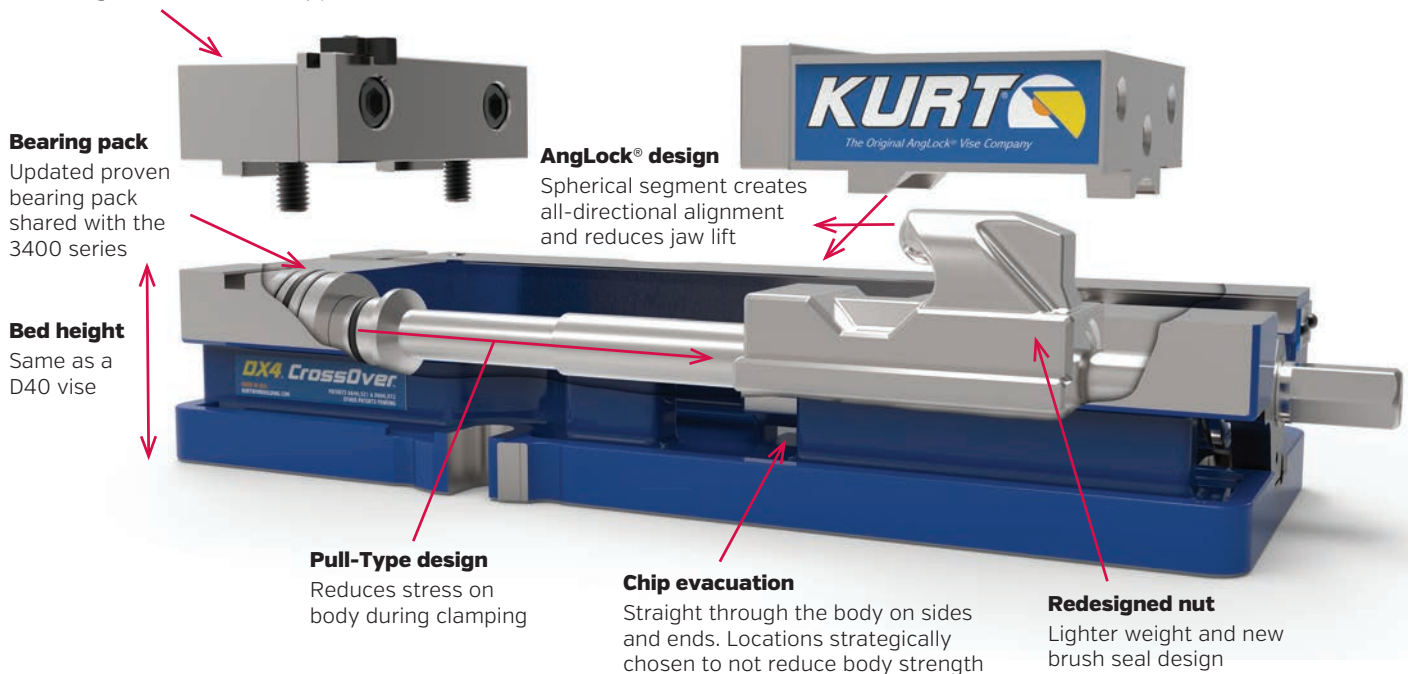



DX6 - MANUAL

Kurt DX6® CrossOver® Vise

Introducing the Kurt DX6® CrossOver® Vise

The evolutionary DX6® CrossOver® Vise combines all the great features of the world-renowned KURT D688 and 3600V vises, along with new state-of-the-art workholding features. DX6® CrossOver® achieves new levels in precision and performance where flatness and parallelism are important and is a better vise than our own D688 in every way we measure a vise.

New hydraulic models come with single and double acting actuation. Only requires switching out a brass fitting with the supplied hydraulic fitting.

Single acting: hydraulic clamping and spring return for unclamping

Double acting: hydraulic to clamp and unclamp for faster, more precise setup

Metric versions available - call factory.



DX6R - MANUAL REVERSE



DX6H - HYDRAULIC



DX6HR - HYDRAULIC REVERSE

DX6H/DX6HR

- New hydraulic model is capable of: Single acting with spring return for unclamp, or Double acting with hydraulic unclamp. Includes fittings for both configurations.
- Threaded ports on body: Female 1/8" NPT
- Included adapters: Male 1/8" NPT to Male #4 JIC, quantity of two

Dimensional Data

DX6/DX6R DX6H/DX6HR

	DX6/DX6R	DX6H/DX6HR
A	2.875	2.875
B	6.000	6.000
C	16.810	16.810
D	3.234	3.234
E	0.656	0.656
F	1.485	1.485
G	2.312	2.312
H	1.735	1.735
I	7.391	7.391
J	1.750	1.750
K	4.000	4.000
L	2.295	2.295
M	0.328	0.328
N	0.940	0.940
O	3.875	3.875
P	1/2-13	1/2-13
P Metric	M12	M12

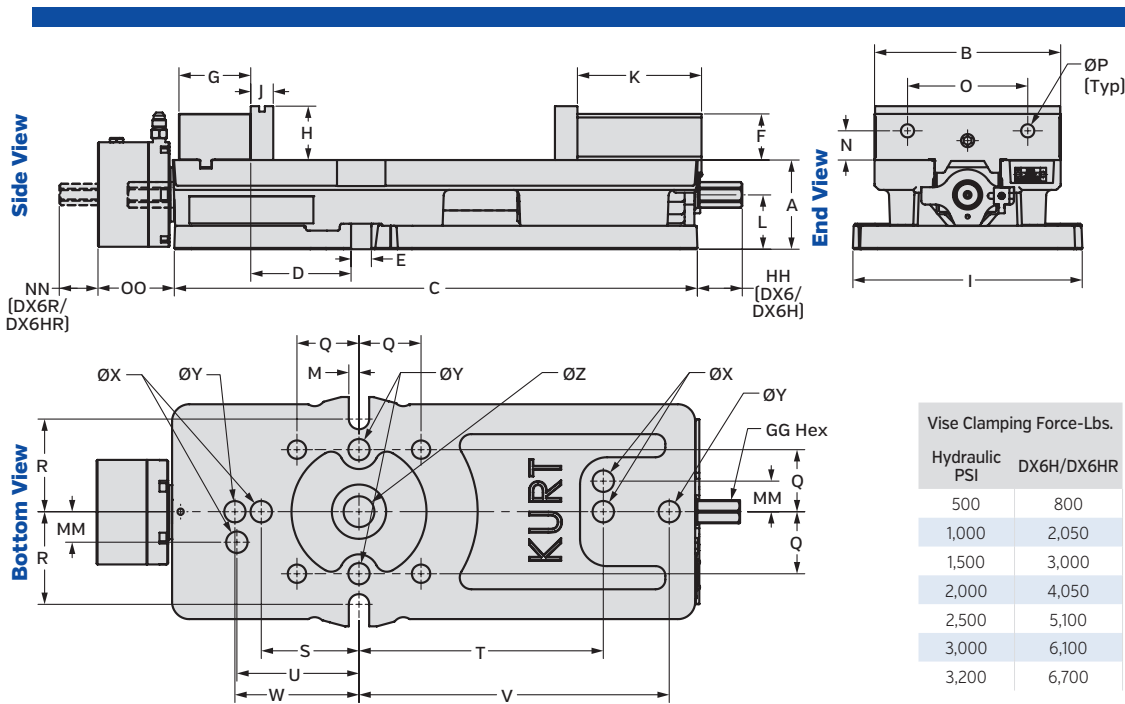

Vise Mounting Options - See page 80

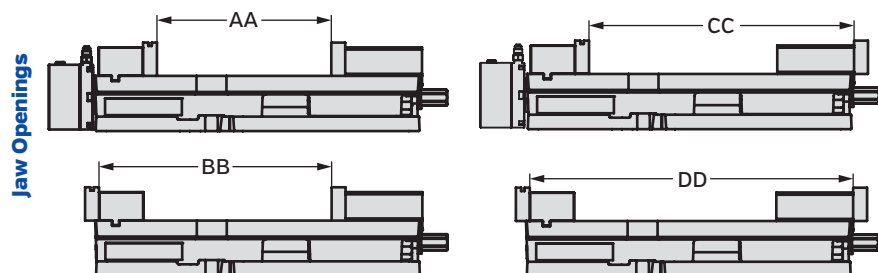

Vise Clamping Force-Lbs.

Hydraulic PSI	DX6H/DX6HR
500	800
1,000	2,050
1,500	3,000
2,000	4,050
2,500	5,100
3,000	6,100
3,200	6,700

Vise Clamping Force-Lbs.

Ft. Lbs	DX6/DX6R
10	786
20	1,800
30	2,508
40	3,423
50	4,210
60	5,020
70	6,287
80	6,884

Q	2.000	2.000
R	2.986	2.986
S	80 mm	80 mm
T	200 mm	200 mm
U	100 mm	100 mm
V	10.000	10.000
W	4.000	4.000
X	16 mm	16 mm
Y	0.625	0.625
Z	0.992	0.992
AA	9.080	9.080
BB	12.117	-
CC	13.805	13.805
DD	16.842	-
GG	3/4	3/4
HH	1.46	1.46
MM	25 mm	25 mm
NN	1.52	1.52
OO	-	2.500
Weight	65 lbs	65 lbs

DX6® CrossOver® Features:

- DX6® CrossOver® vise is a combination of AngLock®, Pull-Type and 4 bolt stationary jaw design. When combined they create an ultra unique strategy for a better vise:
 - AngLock® design reduces stress on body during clamping
 - Pull-type design reduces stress on body during clamping
 - 4 bolt design reduces stationary jaw deflection and alleviates body stress
- Hardened vise bed/jaw plates
- Semi-hard steel screw
- 80,000 psi ductile iron body, nut and movable jaw
- Large 9" opening
- New wider 4 bolt stationary design fastens from the top
- Bolts & locates on 40mm, 50mm and 2" grid patterns
- Accepts sine keys for alignment (not included)
- Chip evacuation straight through the body
- Screw support held in place with snap rings
- Groove Lock® jaw plate and workstop included
- New brush seal design makes it easier to replace
- Includes chip guard
- Powder coat paint is long lasting and durable
- Matching of the bed heights or keyway to stationary jaw (additional cost)
- Fits on D50-4-SA swivel base
- Lifetime Iron Clad Warranty

DX6® CrossOver® features comparison to D688 Vise:

- DX6 is a replacement vise to D688 vise
- Larger opening [9.0" versus 8.8"]
- Same bed height as D688
- Narrower body style than D688 and allows more vises on machine table
- Larger, stronger, and more durable bearing pack lasts longer
- Same distance from the keyway to stationary as D688
- Body height matched $\pm 0.0005"$

DX6® CrossOver® Vise Models available:

- DX6 Manual
- DX6R Manual Reverse
- DX6H Hydraulic
- DX6HR Hydraulic Reverse

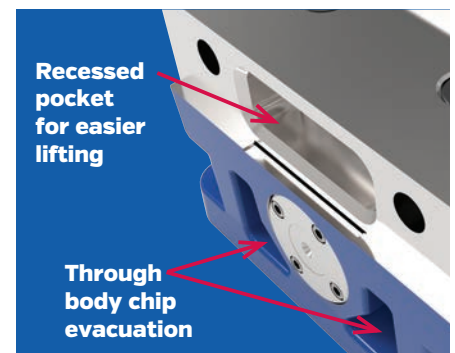
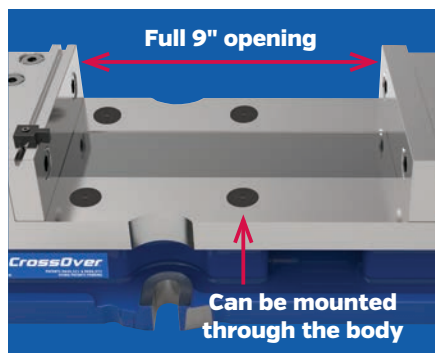
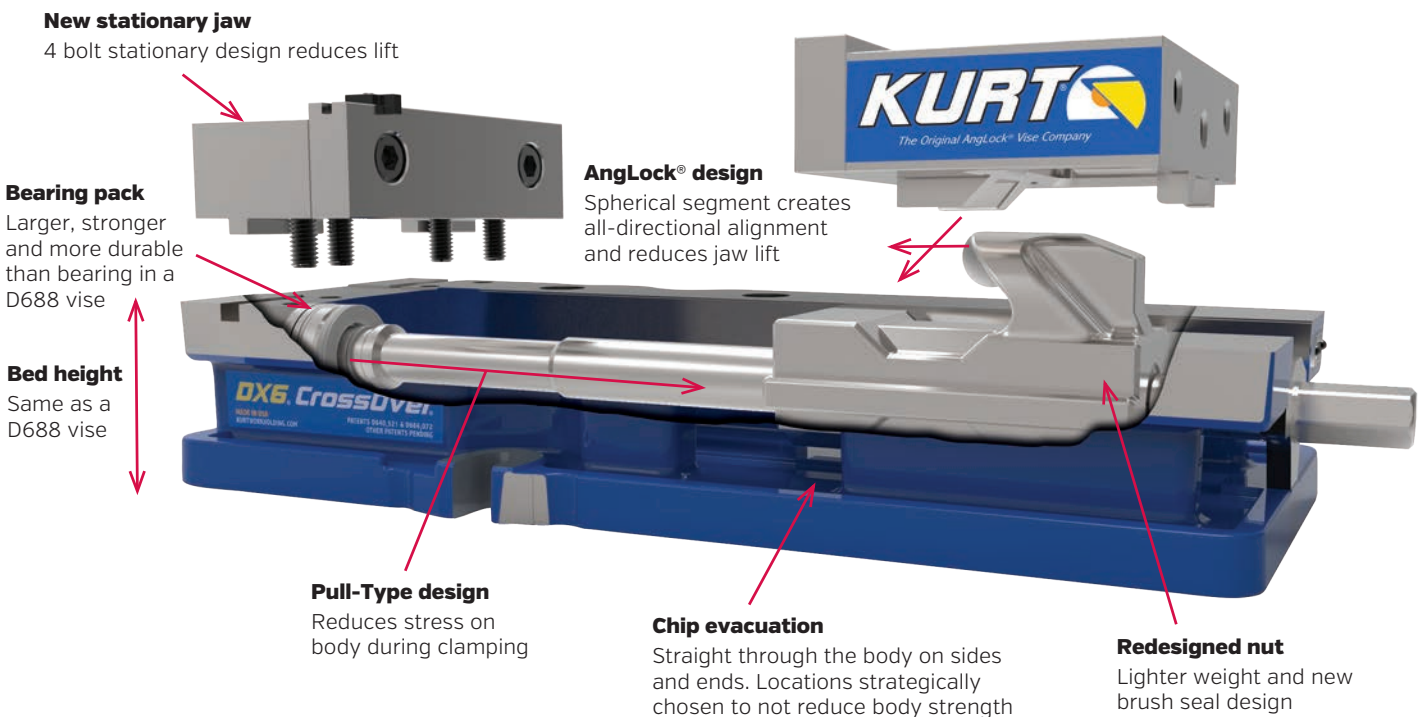

AngLock® D-Series Vises

Features of All D-Series Vises Include:

- AngLock design assures the movable jaw does not lift.
- Standard bed height of ± 0.001 ".
- Matching bed heights within ± 0.001 " at additional cost.
- Hardened vise bed.
- Hardened jaw plates.
- Semi-hard steel screw.
- 80,000-PSI ductile iron body.
- Matching of the keyway to the stationary jaw ± 0.001 " is available for all vises at additional cost.

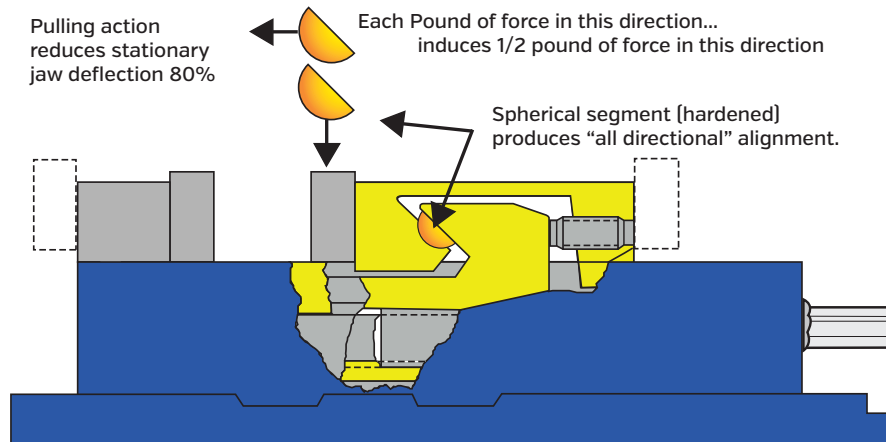

Models: D810 DM810 D100

The original Kurt AngLock D-Series vises are designed for precision part clamping on basic machine tools such as knee-type mills, and machining centers. D-Series vises are ideal for use in running production parts where datums, flatness and parallelism is important. You can precision bore, tap, drill, grind and finish with high accuracy on most parts made of die cast aluminum, steel, and iron in your Kurt AngLock vises. No other brand can give you the time proven accuracy of the Kurt AngLock vises.

All Kurt vises have a friction reducing, needle bearing, thrust collar. The needle bearing increases jaw clamping pressure.



D810 & DM810 (Metric)

Kurt's D810 features a new updated body style:

- Quick Set-up feature.
- Top down, four bolt design on the stationary jaw reduces vise deflection by 25 percent while allowing total disassembly of the vise without removing the body from the machine table. Special brush seals shield and protect vise screw threads from machined chips and residue.
- The nut has been shortened so as not to protrude past the end of the vise body. New powder coat paint finish resists coolant-induced peeling for greater corrosion protection. The overall vise footprint is identical to earlier models so both can be used interchangeably and in tandem.
- With a jaw opening of 10" and clamping force up to 11,600 Lbs., the D810 vise locks parts precisely including very large parts for aggressive "hogging out" operations.

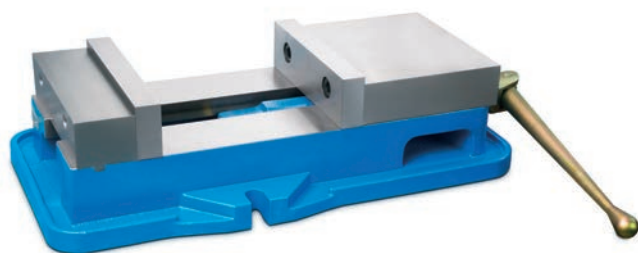

D100

The D100 is the largest and strongest of our general purpose vises. With 9-3/4" of jaw opening, it has the capacity and strength to take on your highest horsepower milling cuts. It's the most precise and rugged 10" production vise in the world.

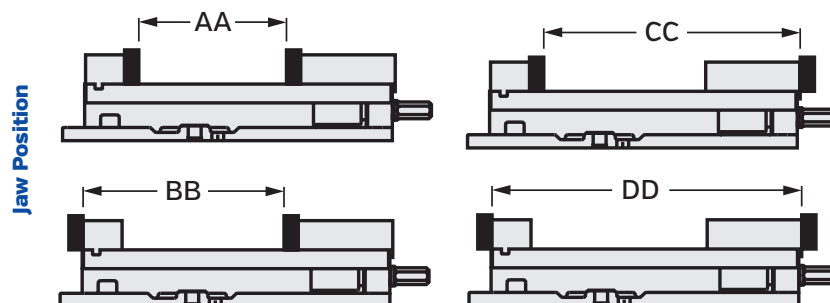
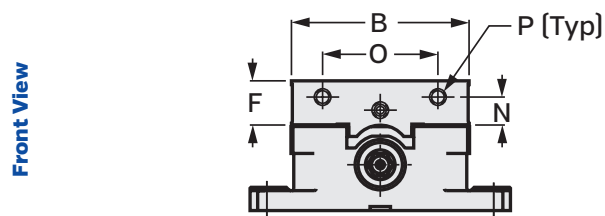
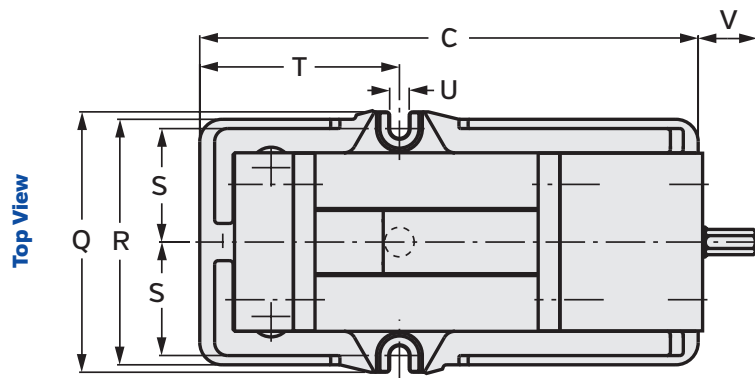
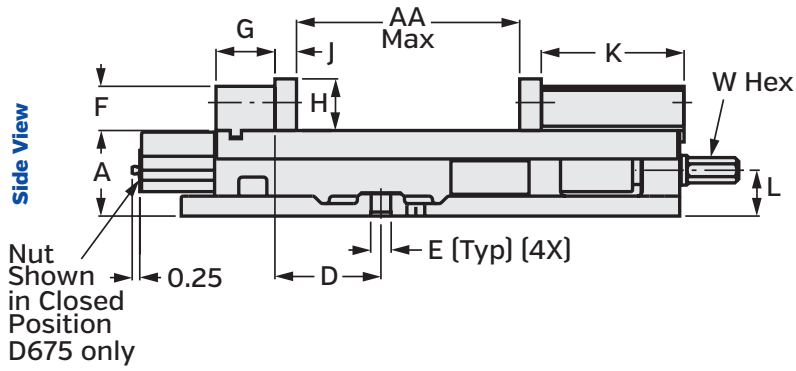

Torque Ft.-Lbs.	Manual Vise Clamping Force-Lbs.	
	D810	D100
10	-	-
20	1,834	1,698
30	-	-
40	3,843	3,300
50	-	-
60	4,349	4,686
70	-	-
80	5,706	6,623
100	7,042	7,842
120	8,688	9,970
140	10,413	11,429
160	11,596	12,792
180	-	14,681
200	-	16,163

	Dimensional Data	
	D810	D100
	Inch	Inch
A	3.310	3.875
B	8.000	10.000
C	21.810	27.500
D	4.686	5.875
E	0.813	0.813
F	1.965	2.465
G	3.652	2.950
H	2.200	2.937
J	1.075	1.320
K	6.190	8.630
L	1.865	2.225
N	1.220	1.625
O	4.750	5.750
P	5/8-11	3/4-10
Q	11.500	14.500
R	11.000	13.250
S	4.940	6.188
T	8.500	10.590
U	0.880	0.940
V	2.375	1.690
W	0.875	1
AA	10	9-3/4
AA Min	0	0
BB	14.730	14.000
BB Min	4.730	3.500
CC	17.260	19.750
CC Min	7.260	9.200
DD	21.990	24.00
DD Min	11.990	13.500
Weight	158	300

Repair Kits

Model	Repair Kit
D30	*D30-KIT
D40	*D40-KIT
D50	*D50-KIT
D60	D60-KIT
D675	*D675-KIT
D688	*D688-KIT
DX6	DX6-KIT
D80	D80-KIT
D810	*D810-KIT
D100	D100-KIT

*= Same as Metric Vise

See page 90 for kit descriptions

VersatileLock® Vises

Manual (3400V) and Hydraulic (3400H)

The VersatileLock vise is the industry's ultimate single station CNC vise. It offers ultra-precision function through these important design features: The original, time proven Kurt AngLock design prevents parts from lifting upward under heavy clamping loads. The "pull-type" jaw clamping reduces stationary jaw deflection by at least 80%. The one piece vise body and stationary jaw provide greater strength while reducing weight.

Features:

- Full 6" Opening.
- Can be mounted upright (3400V) or on either side.
- Matched stationary jaw to keyway including the body height $\pm 0.001"$.
- 0.0005" clamping repeatability.
- Footprint is less than 13". Ideal for the smallest machines.
- All hydraulic units feature a 1/4" vise stroke.
- Groove Lock workstop included.



3400H



3400V

Jaw Position

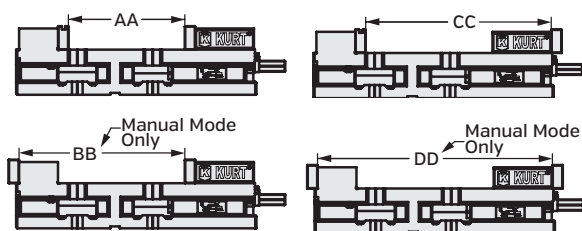

Side View

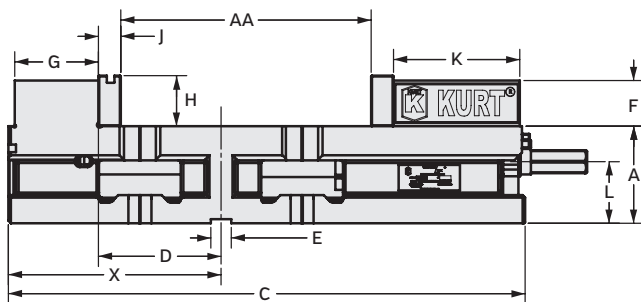
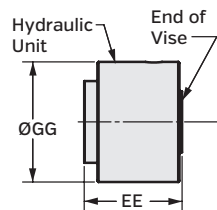

Bottom View

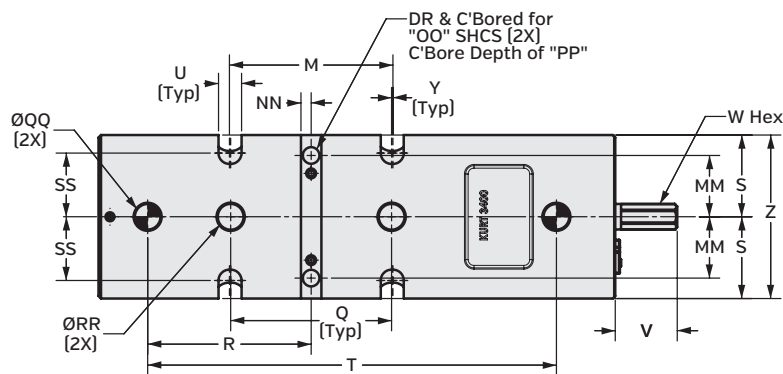

End View

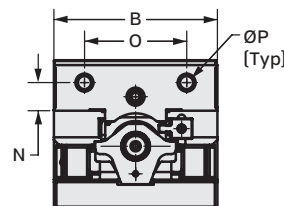

Clamping Force Lbs.	
Torque Ft/Lbs	3400V
10	1,050
20	2,195
30	3,485
40	4,675
50	6,245
60	7,500
Weight	28 Lbs.

Clamping Force Lbs.	
Hydraulic Pressure (Lbs)	3400H
500	350
1,000	1,600
1,500	3,000
2,000	4,300
2,500	5,700
3,000	7,200
Weight	31 Lbs.

Dimensional Data	
	3400V/H
A	2.375
B	4.000
C	12.644
D	3.000
E	0.5005
F	1.115
G	2.047
H	1.235
J	0.547
K	3.090
L	1.505
M	4.000
N	0.687
O	2.500
P	3/8-16*
Q	100 mm
R	4.000
S	2.000
T	10.000
U	0.563
V	0.950
W	9/16*
X	5.203
Y	0.031
Z	4.000
AA	6.000
BB	8.594
CC	9.637
DD	12.231
EE	2.580
FF	-
GG	2.937
MM	1.500
NN	0.2503
OO	3/8*
PP	0.541
QQ	0.6253
RR	M16
SS	1.558

Vise Mounting Options - See page 80

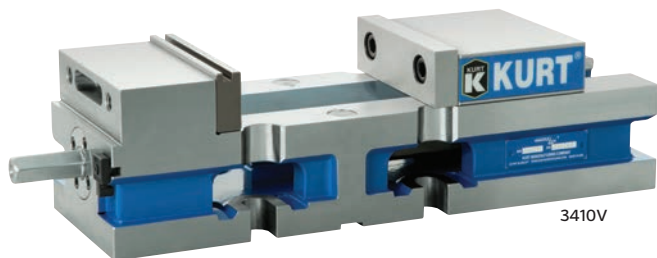

3410V

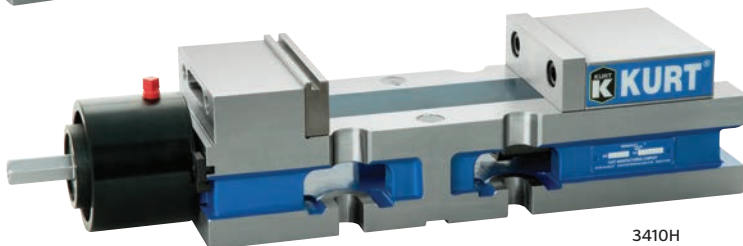

3410H

VersatileLock® Vises

Reverse Manual (3410V) and Reverse Hydraulic (3410H)

Use the VersatileLock in this configuration for the added benefit of easier part programming in “Y axis” positive direction. It also reduces the “reach-over” distance making part loading safer and easier for the operator.

Features:

- Full 6" Opening.
- Can be mounted upright or on either side.
- Matched stationary jaw to the keyway including the body height ± 0.001 ".
- 0.0005" clamping repeatability.
- Footprint is less than 13". Ideal for the smallest machines.
- All hydraulic units feature a 1/4" vise stroke.
- Groove Lock workstop included.
- Weight: 3410V (28 Lbs.)/ 3410H (31 Lbs.)

Jaw Position

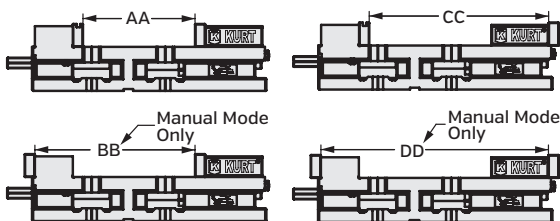

Side View

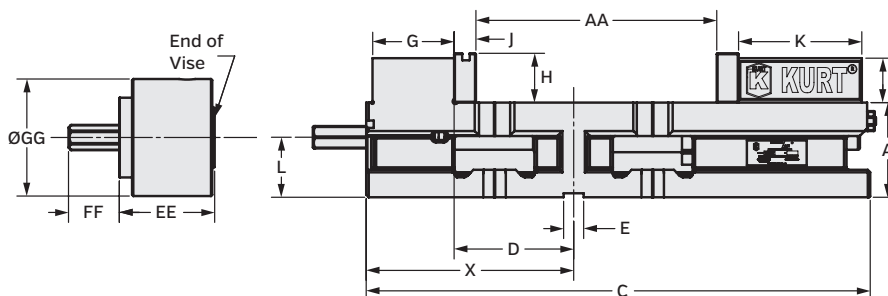

Bottom View

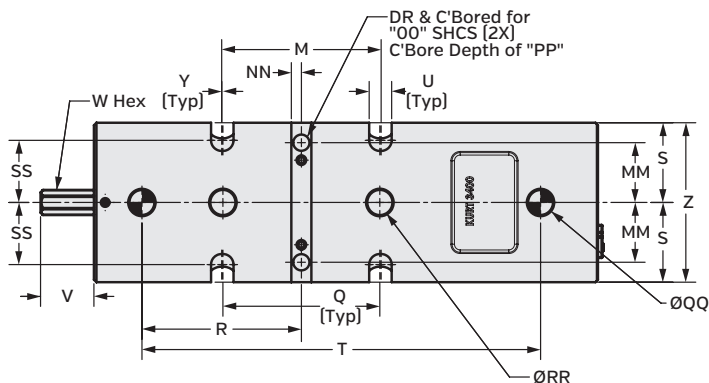

End View

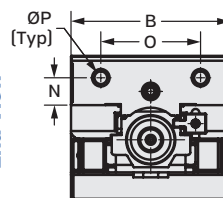

Clamping Force Lbs.	
Torque Ft/Lbs	3410V
10	1,050
20	2,195
30	3,485
40	4,675
50	6,245
60	7,500
Weight	28 Lbs.

Clamping Force Lbs.	
Hydraulic Pressure (Lbs)	3410H
500	350
1,000	1,600
1,500	3,000
2,000	4,300
2,500	5,700
3,000	7,200
Hydraulic Displacement Cu. In	0.80
Weight	31 Lbs.

Dimensional Data	
	3410V/H
A	2.375
B	4.000
C	12.644
D	3.000
E	0.5005
F	1.115
G	2.047
H	1.235
J	0.547
K	3.090
L	1.505
M	4.000
N	0.687
O	2.500
P	3/8-16*
Q	100 mm
R	4.000
S	2.000
T	10.000
U	0.563
V	0.966
W	9/16*
X	5.203
Y	0.031
Z	4.000
AA	6.000
BB	8.594
CC	9.637
DD	12.231
EE	2.580
FF	1.275
GG	2.937
MM	1.500
NN	0.2503
OO	3/8*
PP	0.541
QQ	0.6253
RR	M16
SS	1.558

Vise Mounting Options - See page 80



3600V



3600A - Standard Air



3600H - Standard Hydraulic

VersatileLock® Visers

Standard (3600) and Short (3620) Manual, Hydraulic, and Air Models

The VersatileLock vise is the industry's ultimate single station CNC vise. It offers ultra-precision function through these important design features: The original, time proven Kurt AngLock design prevents parts from lifting upward under heavy clamping loads. The "pull-type" jaw clamping reduces jaw stationary deflection by at least 80%. The one piece vise body and stationary jaw provide greater strength while reducing weight.

Features:

- Can be mounted upright or on either side.
- Matched stationary jaw to keyway including the body height $\pm 0.001"$.
- 0.0005" clamping repeatability.
- Footprint on the short version is 13". Ideal for the smallest machines.
- Hydraulic option is available. See pages 74-75 for KHP5000 hydraulic pumps.
- All air and hydraulic units feature a 1/4" vise stroke.
- Air vise has a precise and repeatable "gentle touch" for delicate parts.
- Optional internal hex available for 3600V only. [3600V-INT].
- Patented

3600H

- New hydraulic model is capable of: Single acting with spring return for unclamp, or Double acting with hydraulic unclamp. Includes fittings for both configurations.
- Threaded ports on body: Female 1/8" NPT
- Included adapters: Male 1/8" NPT to Male #4 JIC, quantity of two

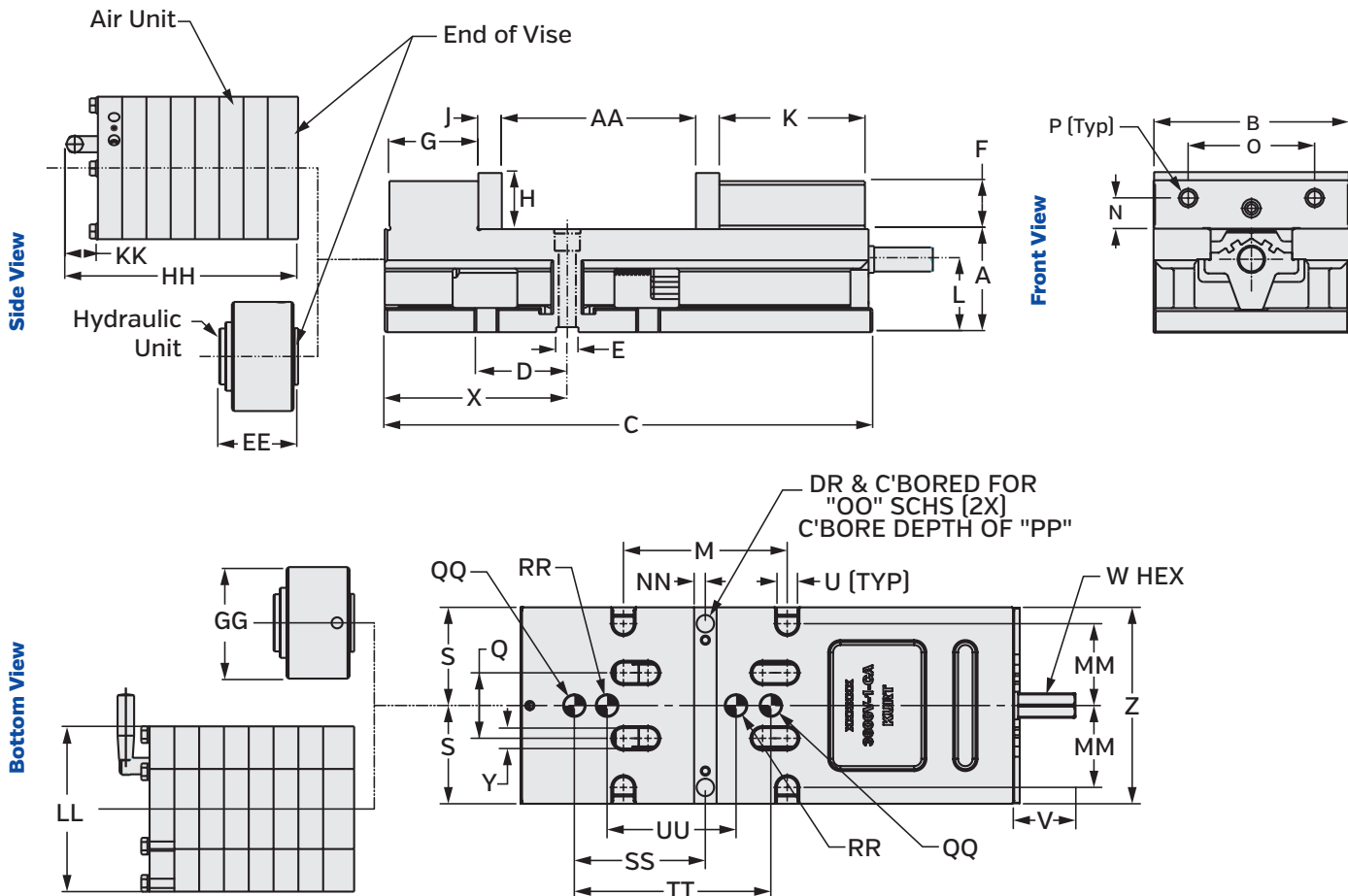



The 3600V shown mounted "back to back". Makes a fast, easy and economical vise tombstone. Bases can be tailored for most HMC's.

See pages 84-85

Repair Kits

Model	Repair Kit
3600V	*3600V-KIT

*= Same as Metric Vise

Vise Clamping Force-Lbs.		
Manual Torque Ft.-Lbs.	Manual	
	3600V	3620V
10	653	653
20	1,743	1743
30	2,234	2,234
40	3,015	3,015
50	3,833	3,833
60	4,438	4,438
70	5,528	5,528
80	6,356	6,356

Vise Clamping Force-Lbs.		
Hydraulic PSI	Hydraulic	
	3600H	3620H
400	900	900
800	1,525	1,525
1,200	2,750	2,750
1,600	3,650	3,650
2,000	4,600	4,600
2,400	5,500	5,500
2,800	6,425	6,425
3,200	7,350	7,350
Hydraulic Displacement Cu. In.	0.69	0.69

Note: Clamping force is only estimated

Vise Clamping Force-Lbs.		
Air PSI	Air	
	3600A	3620A
10	320	320
20	840	840
30	1,280	1,280
40	1,780	1,780
50	2,200	2,200
60	2,720	2,720
70	3,240	3,240
80	3,800	3,800
90	4,380	4,380
100	5,000	5,000

	Dimensional Data							
	Manual		Hydraulic			Air		
	3600V	3600VM	3620V	3600H	3620H	3600A	3620A	
	Inch	mm	Inch	Inch	Inch	Inch	Inch	
A	3.187	80.949	3.187	3.187	3.187	3.187	3.187	
B	6.000	152.400	6.000	6.000	6.000	6.000	6.000	
C	15.060	382.524	12.940	15.060	12.940	15.060	12.940	
D	2.750	69.850	2.750	2.750	2.750	2.750	2.750	
E	0.688	17.475	0.688	0.688	0.688	0.688	0.688	
F	1.485	37.719	1.485	1.485	1.485	1.485	1.485	
G	2.750	69.850	2.750	2.750	2.750	2.750	2.750	
H	1.735	44.069	1.735	1.735	1.735	1.735	1.735	
J	0.725	18.415	0.725	0.725	0.725	0.725	0.725	
K	4.500	114.300	4.500	4.500	4.500	4.500	4.500	
L	2.250	57.150	2.250	2.250	2.250	2.250	2.250	
M	5.000	127.000	5.000	5.000	5.000	5.000	5.000	
N	0.937	23.800	0.937	0.937	0.937	0.937	0.937	
O	3.875	98.425	3.875	3.875	3.875	3.875	3.875	
P	1/2-13	M12 X 25	1/2-13	1/2-13	1/2-13	1/2-13	1/2-13	
Q	2.000	50.800	2.000	2.000	2.000	2.000	2.000	
R	4.250	107.950	4.250	4.250	4.250	4.250	4.250	
S	3.000	76.200	3.000	3.000	3.000	3.000	3.000	
T	1.380	35.025	1.380	1.380	1.380	1.380	1.380	
U	0.630	16.002	0.630	0.630	0.630	0.630	0.630	
V	1.940	49.276	1.940	1.940	1.940	1.940	1.940	
W	3/4	3/4	3/4	3/4	3/4	3/4	3/4	
X	5.640	143.256	5.640	5.640	5.640	5.640	5.640	
Y	0.630	16.002	0.630	0.630	0.630	0.630	0.630	
Z	6.000	152.400	6.000	6.000	6.000	6.000	6.000	
AA	6.000	152.400	4.000	6.000	4.000	6.000	4.000	
BB	9.500	241.300	7.500	-	-	-	-	
CC	11.250	285.750	9.250	11.250	9.250	11.250	9.250	
DD	14.750	-	12.750	-	-	-	-	
EE	-	-	-	2.500	2.500	-	-	
GG	-	-	-	3.375	3.375	-	-	
HH	-	-	-	-	-	7.220	7.220	
KK	-	-	-	-	-	1.030	1.030	
LL	-	-	-	-	-	5.000	5.000	
MM	2.500	374.650	2.500	2.500	2.500	2.500	2.500	
NN	0.344	63.500	0.344	0.344	0.344	0.344	0.344	
OO	1/2	M12	1/2	1/2	1/2	1/2	1/2	
PP	0.671	17.043	0.671	0.671	0.671	0.671	0.671	
QQ	0.625	0.625	0.625	0.625	0.625	0.625	0.625	
RR	16 MM	16 MM	16 MM	16 MM	16 MM	16 MM	16 MM	
SS	4.000	4.000	4.000	4.000	4.000	4.000	4.000	
TT	6.000	6.000	6.000	6.000	6.000	6.000	6.000	
UU	100 MM	100 MM	100 MM	100 MM	100 MM	100 MM	100 MM	
Est. Weight	69 Lbs.	32 Kgs.	64 Lbs.	74 Lbs.	69 Lbs.	75 Lbs.	70 Lbs.	

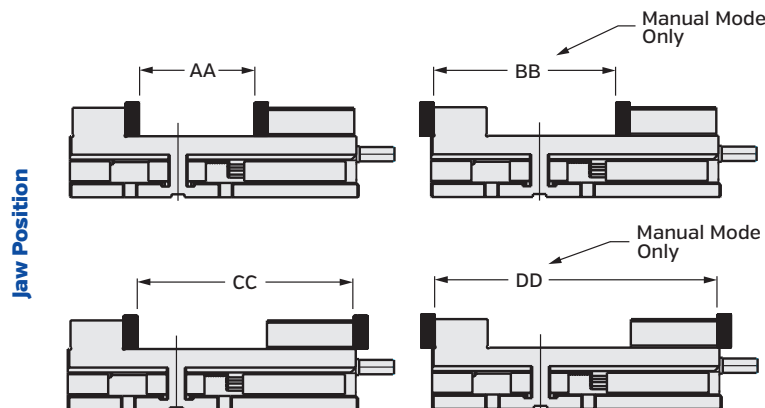

VersatileLock® Vises

Reverse (3610) and Short Reverse (3630) Manual, Hydraulic, and Air Models

Use the VersatileLock in this configuration for the added benefit of easier part programming in "Y axis" positive direction. It also reduces the "reach-over" distance making part loading safer and easier for the operator.

Features:

- Can be mounted upright or on either side.
- Matched stationary jaw to the keyway including the body height ± 0.001 ".
- 0.0005" clamping repeatability.
- Footprint on the short version is 13". Ideal for the smallest machines.
- All air and hydraulic units feature a 1/4" vise stroke.
- Air vise has a precise and repeatable "gentle touch" for delicate parts.
- Some models available in metric.
- Patented

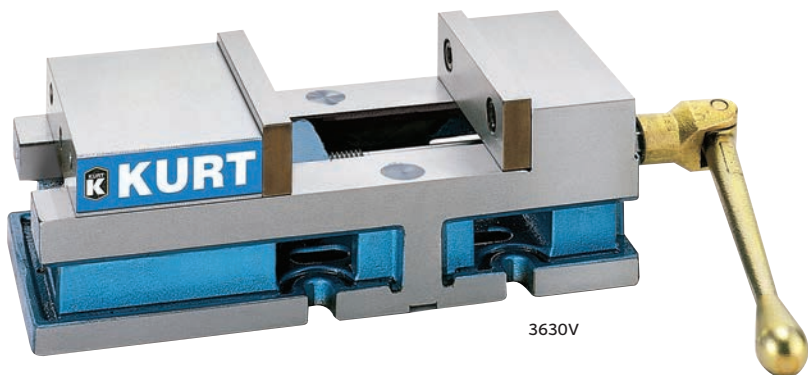

3630V

3610H and 3630H

- New hydraulic model is capable of: Single acting with spring return for unclamp, or Double acting with hydraulic unclamp. Includes fittings for both configurations.
- Threaded ports on body: Female 1/8" NPT
- Included adapters: Male 1/8" NPT to Male #4 JIC, quantity of two

Side View

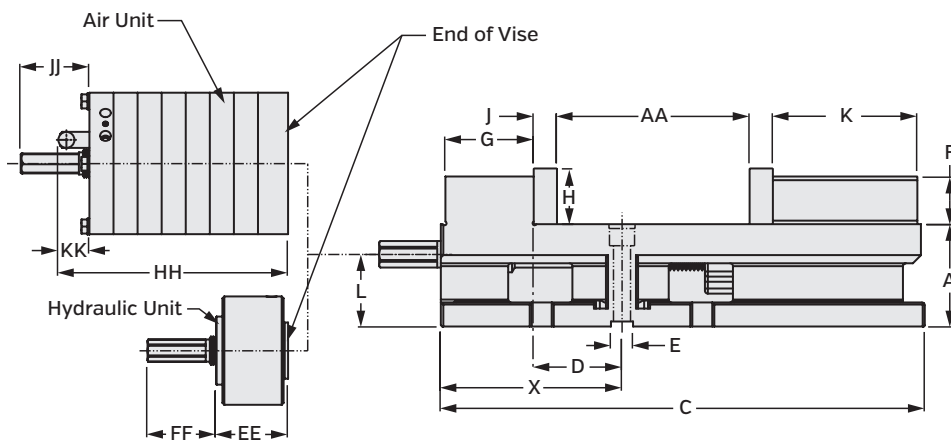

Front View

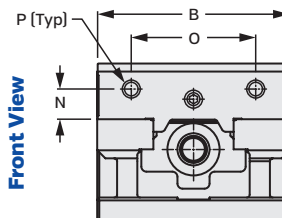

Bottom View

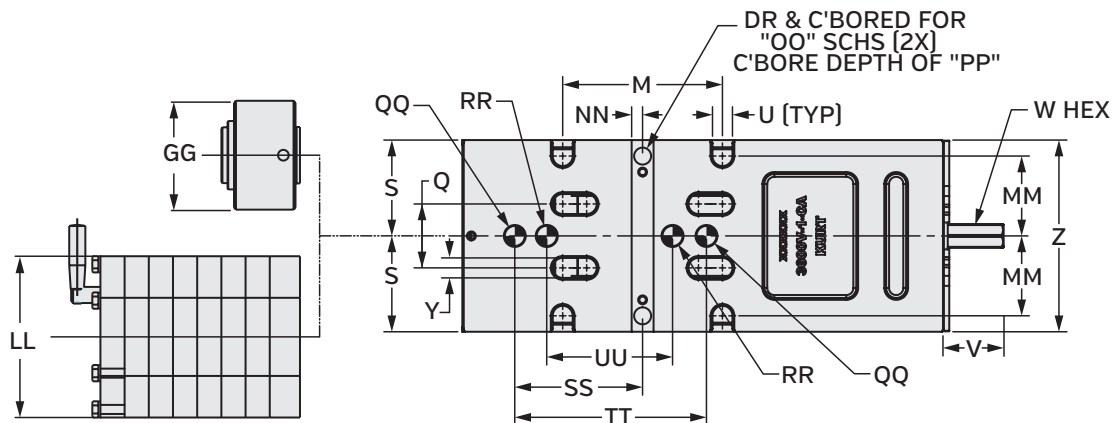

Jaw Position

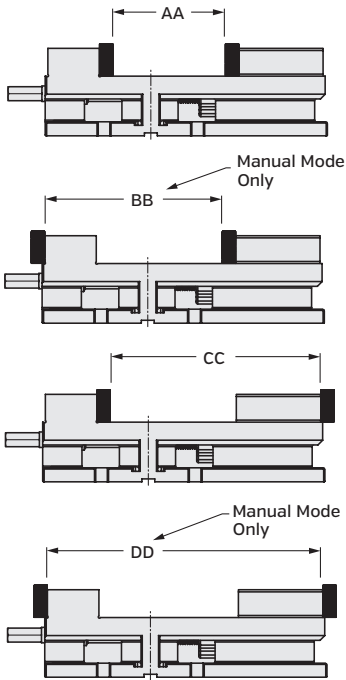

Manual torque Ft.-Lbs.	Vise Clamping Force-Lbs.	
	Manual	
	3610V	3630V
10	653	653
20	1,743	1,743
30	2,234	2,234
40	3,015	3,015
50	3,833	3,833
60	4,438	4,438
70	5,528	5,528
80	6,356	6,356

Hydraulic PSI	Vise Clamping Force-Lbs.	
	Hydraulic	
	3610H	3630H
400	900	900
800	1,525	1,525
1,200	2,750	2,750
1,600	3,650	3,650
2,000	4,600	4,600
2,400	5,500	5,500
2,800	6,425	6,425
3,200	7,350	7,350
Hydraulic Displacement Cu. In	0.69	0.69

Note: Clamping force is only estimated

Air PSI	Vise Clamping Force-Lbs.	
	Air	
	3610A	3630A
10	320	320
20	840	840
30	1,280	1,280
40	1,780	1,780
50	2,200	2,200
60	2,720	2,720
70	3,240	3,240
80	3,800	3,800
90	4,380	4,380
100	5,000	5,000

	Dimensional Data					
	Manual		Hydraulic		Air	
	3610V	3630V	3610H	3630H	3610A	3630A
A	3.187	3.187	3.187	3.187	3.187	3.187
B	6.000	6.000	6.000	6.000	6.000	6.000
C	15.060	12.940	15.060	12.940	15.060	12.940
D	2.750	2.750	2.750	2.750	2.750	2.750
E	0.688	0.688	0.688	0.688	0.688	0.688
F	1.485	1.485	1.485	1.485	1.485	1.485
G	2.750	2.750	2.750	2.750	2.750	2.750
H	1.735	1.735	1.735	1.735	1.735	1.735
J	0.725	0.725	0.725	0.725	0.725	0.725
K	4.500	4.500	4.500	4.500	4.500	4.500
L	2.250	2.250	2.250	2.250	2.250	2.250
M	5.000	5.000	5.000	5.000	5.000	5.000
N	0.937	0.937	0.937	0.937	0.937	0.937
O	3.875	3.875	3.875	3.875	3.875	3.875
P	1/2-13	1/2-13	1/2-13	1/2-13	1/2-13	1/2-13
Q	2.000	2.000	2.000	2.000	2.000	2.000
R	4.250	4.250	4.250	4.250	4.250	4.250
S	3.000	3.000	3.000	3.000	3.000	3.000
T	1.380	1.380	1.380	1.380	1.380	1.380
U	0.630	0.630	0.630	0.630	0.630	0.630
V	1.940	1.940	1.940	1.940	1.940	1.940
W	3/4	3/4	3/4	3/4	-	-
X	5.640	5.640	5.640	5.640	5.640	5.640
Y	0.630	0.630	0.630	0.630	0.630	0.630
Z	6.000	6.000	6.000	6.000	6.000	6.000
AA	6.000	4.000	6.000	4.000	6.000	4.000
BB	9.500	7.500	-	-	-	-
CC	11.250	9.250	11.250	9.250	11.250	9.250
DD	14.750	12.750	-	-	-	-
EE	-	-	2.500	2.500	-	-
FF	-	-	1.940	1.940	-	-
GG	-	-	3.375	3.375	-	-
HH	-	-	-	-	7.220	7.220
JJ	-	-	-	-	2.100	2.100
KK	-	-	-	-	1.030	1.030
LL	-	-	-	-	5.000	5.000
MM	2.500	2.500	2.500	2.500	2.500	2.500
NN	0.344	0.344	0.344	0.344	0.344	0.344
OO	1/2	1/2	1/2	1/2	1/2	1/2
PP	0.671	0.671	0.671	0.671	0.671	0.671
QQ	0.625	0.625	0.625	0.625	0.625	0.625
RR	16 MM	16 MM	16 MM	16 MM	16 MM	16 MM
SS	4.000	4.000	4.000	4.000	4.000	4.000
TT	6.000	6.000	6.000	6.000	6.000	6.000
UU	100MM	100MM	100MM	100MM	100MM	100MM
Weight Lbs.	68	64	73	68	74	69



KHP5000 Hydraulic Pump, page 77



KHP3H Hydraulic Pump page 76



KHP3F Hydraulic Pump page 76



Automation Pump page 76

VersatileLock® Vises

Manual (3800V) and Hydraulic (3800H)

The VersatileLock vise is the industry's ultimate single station CNC vise. It offers ultra-precision function through these important design features: The original, time proven Kurt AngLock design prevents parts from lifting upward under heavy clamping loads. The "pull-type" jaw clamping reduces stationary jaw deflection by at least 80%. The one piece vise body and stationary jaw provide greater strength while reducing weight.

Features:

- Full 10" opening.
- Can be mounted upright (3800V) or on either side.
- Matched stationary jaw to keyway including the body height $\pm 0.001"$.
- 0.0005" clamping repeatability.
- All hydraulic units feature a 1/4" vise stroke.



3800H



3800V

Torque Ft/Lbs	Clamping Force Lbs.		Clamping Force Lbs.		Dimensional Data		
	3800V	3800H	Hydraulic Pressure (Lbs)	3800H	3800V	3800H	
10	625				A	3.750	3.750
20	1,000		500	1,500	B	8.000	8.000
30	1,625		1,000	3,000	C	22.000	22.000
40	2,025		1,500	4,500	D	4.812	4.812
50	2,625		2,000	6,000	E	0.813	0.813
60	3,450		2,500	7,500	F	1.965	1.965
70	4,050		3,000	9,000	G	3.500	3.500
80	5,100		3,200	11,000	H	14.000	14.000
90	6,150				J	1.075	1.075
100	6,550				K	6.000	6.000
					L	2.305	2.305
					M	5.953	5.953
					N	1.220	1.220
					O	4.750	4.750
					P	5/8-11	5/8-11
					Q	300 mm	300 mm
					R	12.7 mm	12.7 mm
					S	4.000	4.000
					T	16 mm	16 mm
					U	0.927	0.927
					V	2.000	2.000
					W	5.000	5.000
					X	8.531	8.531
					Y	100 mm	100 mm
					Z	8.000	8.000
					AA	10.250	10.250
					BB	14.825	14.825
					CC	17.325	17.325
					DD	21.900	21.900
					EE	-	2.982
					FF	-	2.000
					GG	-	3.750
					HH	2.200	2.200
					MM	3.000	3.000
					NN	0.407	0.407
					OO	5/8	5/8
					PP	0.790	0.790
					QQ	0.625	0.625
					RR	0.500	0.500
					Est. Weight	148 Lbs	155 Lbs

Jaw Position

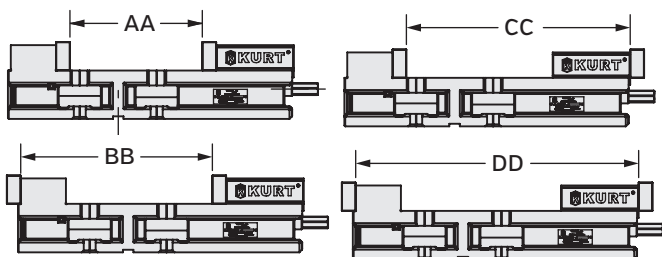

Side View

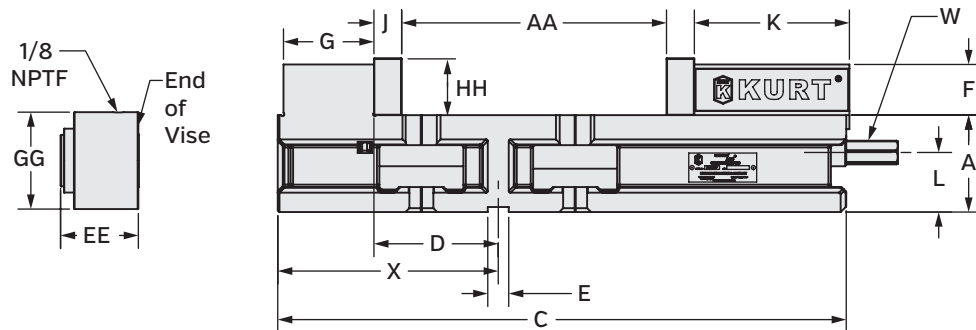

Bottom View

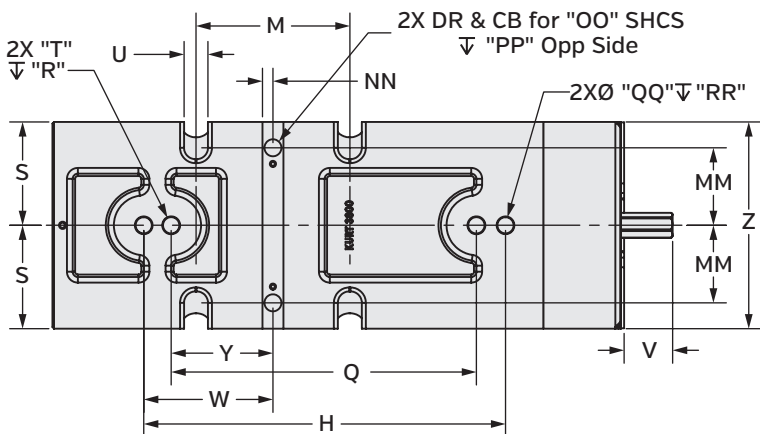

End View

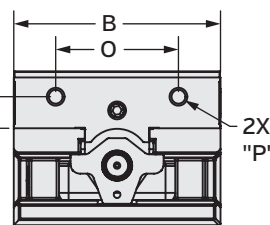

Vise Mounting Options - See page 80

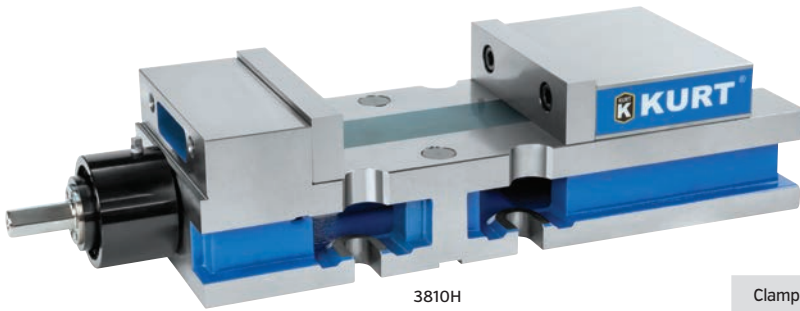
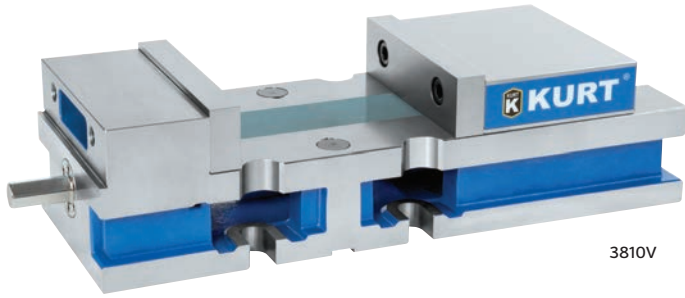

VersatileLock® Vises

Reverse Manual (3810V) and Reverse Hydraulic (3810H)

VersatileLock vises are available in reverse configuration for the added benefit of easier part configuration for the added benefit of easier part programming in "Y axis" positive direction. It also reduces the "reach-over" distance making part loading safer and easier for the operator.

Features:

- Full 10" opening.
- Can be mounted upright (3810V) or on either side.
- Matched stationary jaw to the keyway including the body height $\pm 0.001"$.
- 0.0005" clamping repeatability.
- All hydraulic units feature a 1/4" vise stroke.

Clamping Force LBS.		Clamping Force Lbs.		Dimensional Data		
Torque Ft/Lbs	3810V	Hydraulic Pressure (Lbs)	3810H	3810V	3810H	
10	625	500	1,500	A	3.750	3.750
20	1,000	1,000	3,000	B	8.000	8.000
30	1,625	1,500	4,500	C	22.000	22.000
40	2,025	2,000	6,000	D	4.812	4.812
50	2,625	2,500	7,500	E	0.813	0.813
60	3,450	3,000	9,000	F	1.965	1.965
70	4,050	3,200	11,000	G	3.500	3.500
80	5,100	Hydraulic Displacement Cu In 1.82		H	14.000	14.000
90	6,150		J	1.075	1.075	
100	6,550		K	6.000	6.000	
			L	2.305	2.305	
				M	5.953	5.953
				N	1.220	1.220
				O	4.750	4.750
				P	5/8-11	5/8-11
				Q	300 mm	300 mm
				R	12.7 mm	12.7 mm
				S	4.000	4.000
				T	16 mm	16 mm
				U	0.927	0.927
				V	2.000	2.000
				W	5.000	5.000
				X	8.531	8.531
				Y	100 mm	100 mm
				Z	8.000	8.000

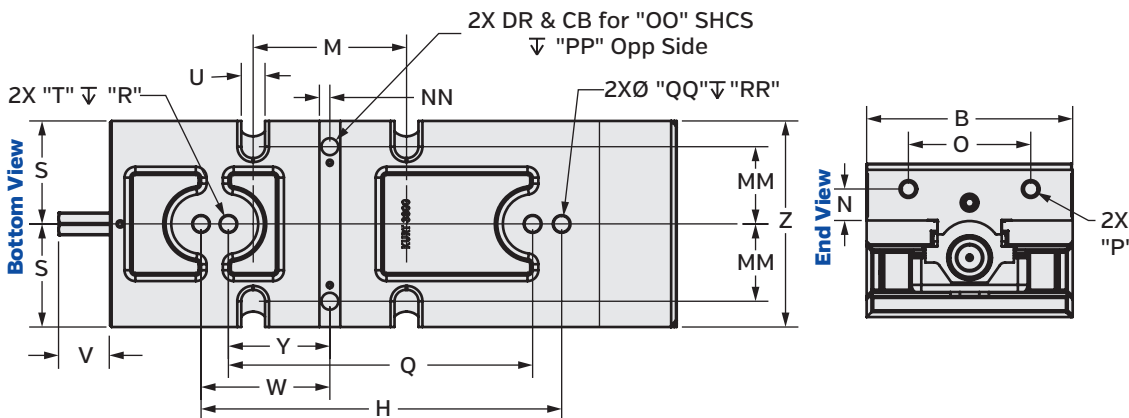
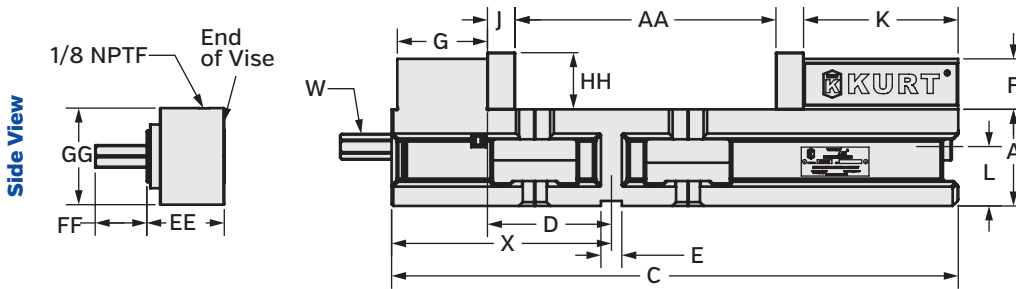
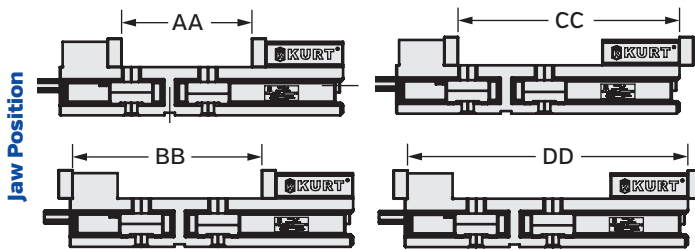

Vise Mounting Options - See page 80



HD690

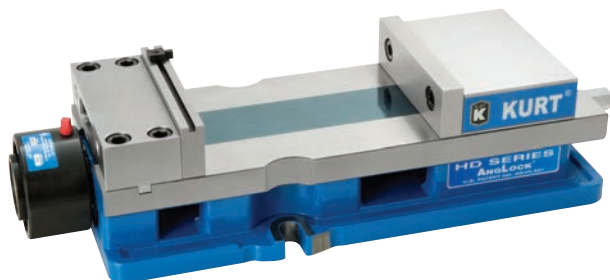

HDH690

- New hydraulic model is capable of: Single acting with spring return for unclamp, or Double acting with hydraulic unclamp. Includes fittings for both configurations.
- Threaded ports on body: Female 1/8" NPT
- Included adapters: Male 1/8" NPT to Male #4 JIC, quantity of two

HD690 Vises

- A full 9 inch opening between jaws when using standard hard jaw plates.
- Less deflection of stationary jaw. Wider more stable stationary jaw equals less deflection.
- Stationary jaw bolts down from top. No need to remove from table to disassemble vise. Bolting the stationary from the top reduces the stress in the body and will stay flatter after assembly.
- Narrower body width allows more vises in the same work envelope.
- Taller body design equals less deflection under clamping loads.
- Bolts and locates directly on standard grid plates: 40mm, 50mm or 2 inch.
- Pull type body design reduces stress in the body resulting in more accurate clamping.
- Quick change movable jaw. The HD platform movable jaw allows for quick change and carvability to hold that odd shaped part.
- Groove Lock jaw and workstop included.
- Uses sine keys for alignment.
- Swivel base available. Part No. D50-4-SA
- Bed height matched $\pm 0.0005"$
- Weight: HD690/HDM690 (75 Lbs.), HDH690 (80 Lbs.)
- Patented.

Vise Clamping Force-Lbs.		Vise Clamping Force-Lbs.		Dimensional Data	
Manual Torque Ft.-Lbs.	HD690 HDM690	Hydraulic PSI	HDH690	HD690/HDM690 HDH690	
10	975	400	900	A	3.125
20	1,625	800	1,525	B	6.000
30	2,400	1,200	2,750	C	16.810
40	3,250	1,600	3,650	D	3.375
50	3,700	2,000	4,600	E	0.6600
60	4,275	2,400	5,500	F	1.485
70	4,700	2,800	6,425	G	2.312
80	5,250	3,200	7,350	H	1.735
		Hydraulic Displacement Cu. In.	0.69	I	7.338
				J	0.725
				K	4.000
				L	2.000
				M	0.330
				N	0.940
				O	3.875
				P	1/2-13
				P Metric	M12
				Q	2.000
				R	2.986
				S	50 mm
				T	200 mm
				U	80 mm
				V	10.000
				W	4.000
				X	16 mm
				Y	0.625
				Z	0.992
				AA	9.062
				BB	12.099
				CC	13.787
				DD	16.824
				EE	2.500
				FF	3.375
				GG	3/4
				HH	1.508

Note: Clamping force is only estimated

Jaw Position

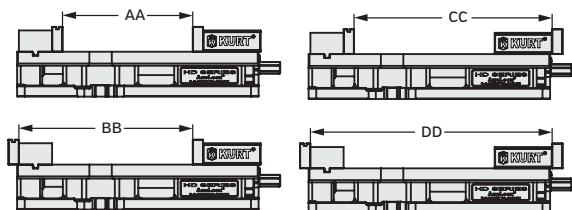

Side View

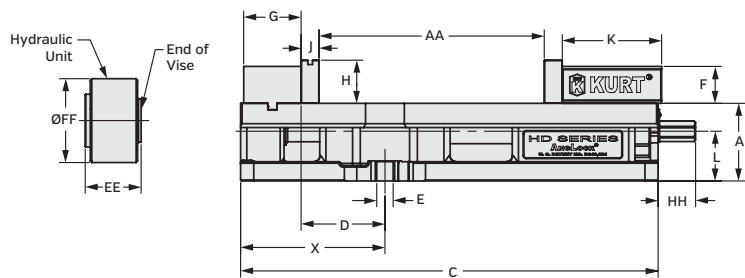

Bottom View

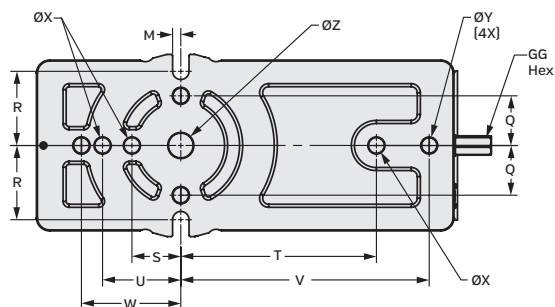

End View

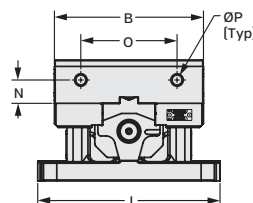

HD690 Aluminum Machinable Kit
Part No. HD690AL-JAWKIT



Vise Mounting Options - See page 80

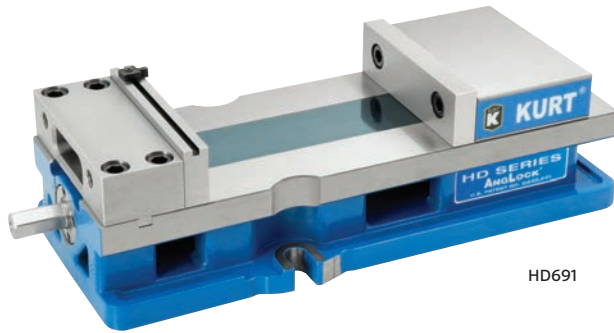

HD691

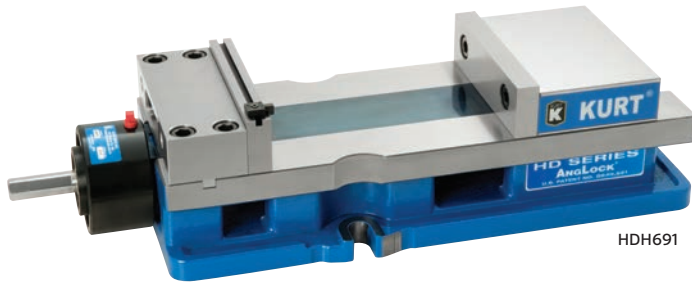

HDH691

HDH691

- New hydraulic model is capable of: Single acting with spring return for unclamp, or Double acting with hydraulic unclamp. Includes fittings for both configurations.
- Threaded ports on body: Female 1/8" NPT
- Included adapters: Male 1/8" NPT to Male #4 JIC, quantity of two

HD691 Vises

- Easier programming in the "Y" axis positive direction
- Reduces "reach-over" distance making part loading safer and easier
- A full 9 inch opening between jaws when using standard hard jaw plates.
- Less deflection of stationary jaw. Wider more stable stationary jaw equals less deflection.
- Stationary jaw bolts down from top. No need to remove from table to disassemble vise. Bolting the stationary from the top reduces the stress in the body and will stay flatter after assembly.
- Narrower body width allows more vises in the same work envelope.
- Taller body design equals less deflection under clamping loads.
- Bolts and locates directly on standard grid plates: 40mm, 50mm or 2 inch.
- Pull type body design reduces stress in the body resulting in more accurate clamping.
- Quick change movable jaw. The HD platform movable jaw allows for quick change and carvability to hold that odd shaped part.
- Groove Lock jaw and workstop included.
- Uses sine keys for alignment.
- Swivel base available. Part No. D50-4-SA
- Bed height matched $\pm 0.0005"$
- Weight: HD691 [75 Lbs.], HDH691 [80 Lbs.]
- Patented.

Vise Clamping Force-Lbs.	Vise Clamping Force-Lbs.		Dimensional Data			
	Manual Torque Ft.-Lbs.	HD691	Hydraulic PSI	HDH691	HD691	HDH691
10		975	400	900	A	3.125
20		1,625	800	1,525	B	6.000
30		2,400	1,200	2,750	C	16.810
40		3,250	1,600	3,650	D	3.375
50		3,700	2,000	4,600	E	0.6600
60		4,275	2,400	5,500	F	1.485
70		4,700	2,800	6,425	G	2.312
80		5,250	3,200	7,350	H	1.735
			Hydraulic Displacement Cu. In.	0.69	I	7.338
			Note: Clamping force is only estimated		J	0.725
					K	4.000
					L	2.000
					M	0.330
					N	0.940
					O	3.875
					P	1/2-13
					P Metric	M12
					Q	2.000
					R	2.986
					S	50 mm
					T	200 mm
					U	80 mm
					V	10.000
					W	4.000
					X	16 mm
					Y	0.625
					Z	0.992
					AA	9.062
					BB	12.099
					CC	13.787
					DD	16.824
					EE	2.500
					FF	3.375
					GG	3/4
					HH	1.575

Jaw Position

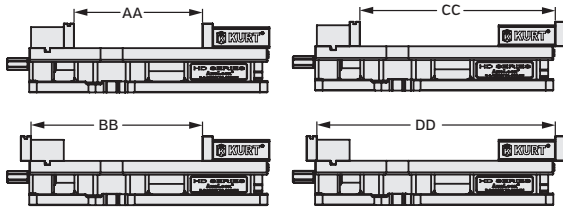

Side View

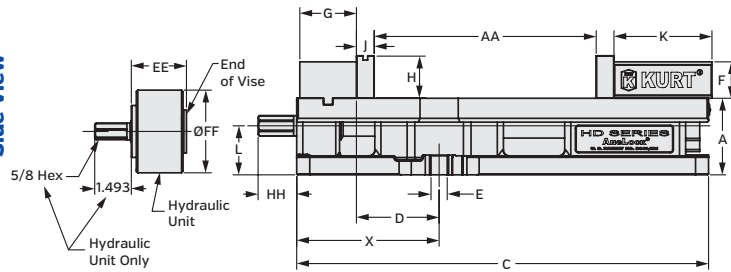

Bottom View

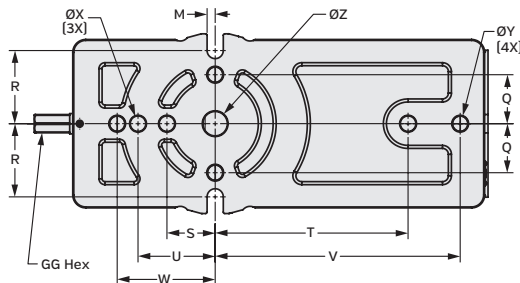

End View

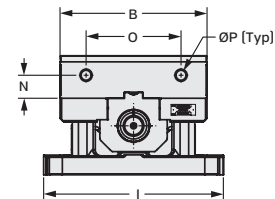

Vise Mounting Options - See page 80

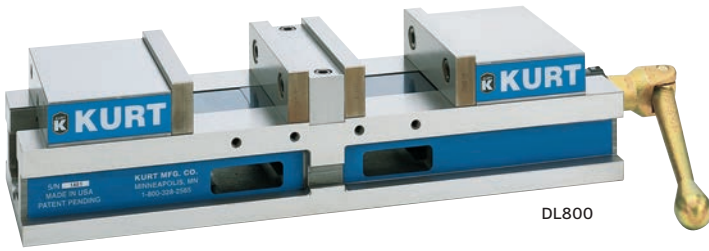

DL800

DoubleLock® Vises (Manual)

DL800 Features:

- Large Capacity -DL800 8" wide x 6" opening each station.
- Productivity – multiple part workholding for better spindle utilization, reduced tool change time, and reduced machine travel from part to part.
- Accuracy – repeatable clamping to 0.0002".
- Durability – 80,000-PSI ductile iron body and steel components provide strength, rigidity and long term accuracy while absorbing machining vibration.
- Self-adjusting holding block over the entire clamping range.
- Metric version available.
- Optional internal hex screw available.
- Pre-load is adjustable from 0.010" to 0.150".
- New holding block features the ability to clamp dissimilar sized parts and provides preloading ability in the front or back jaw.
- Patented



DLH800

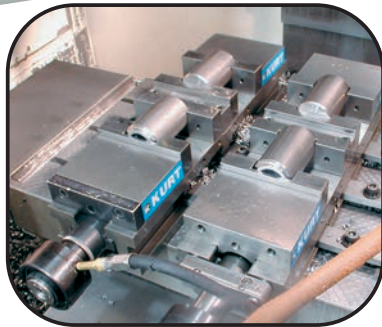

DoubleLock® Vises (Hydraulic)

DLH800 Features:

- Repeatable clamping (0.0002") for high accuracy machining and handles a higher horsepower cut than the manual version.
- Compact design features a wide range of clamping forces up to 9,450 Lbs. 1/4" stroke - 1/8" per side.
- Productivity – multiple part workholding for better spindle utilization, reduced tool change time, and reduced machine travel from part to part.
- Durability – 80,000-PSI ductile iron body and steel components provide strength, rigidity and long term accuracy while absorbing machining vibration.
- Patented

Optional Convertible Kit – Jaw Positions

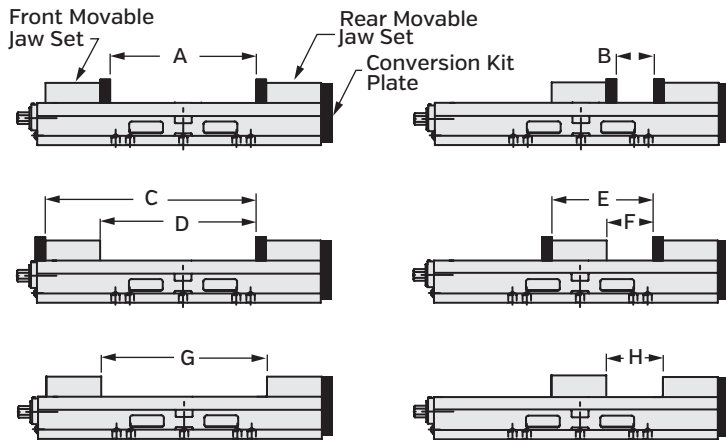

Shown with optional convertible kit.

Use your DoubleLock vise to it's full capacity with the DoubleLock convertible kit. The kit is available for the DL800 vise. DLC800-KIT



KHP3H Hydraulic Pump, page 76



KHP5000 Hydraulic Pump, page 77

Optional Convertible Kit - Jaw Opening Positions

Part #	A	B	C	D	E	F	G	H	Wt. Lbs
DLC800 - KIT	16,000	12,000	23,000	17,000	19,000	13,000	18,000	14,000	20

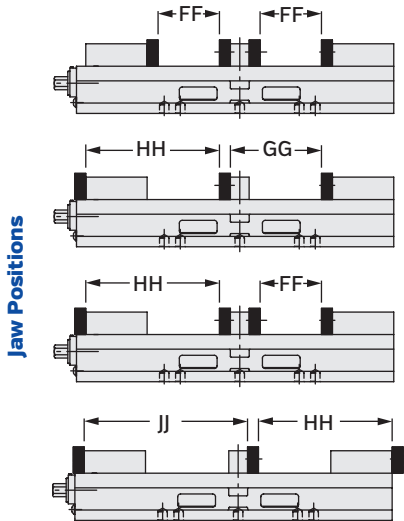
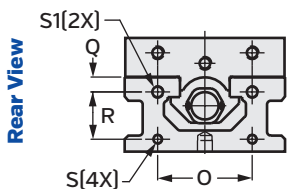
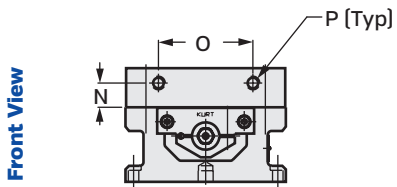
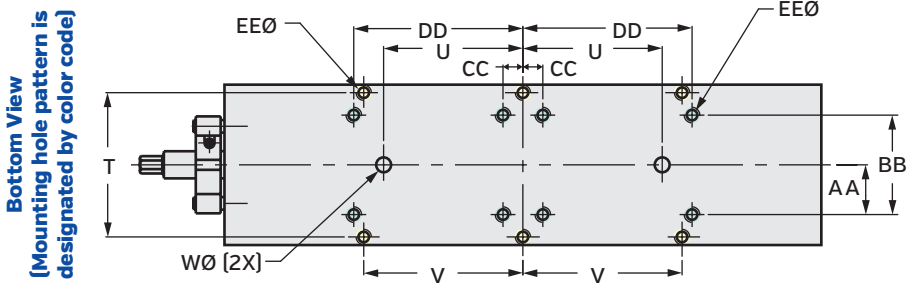
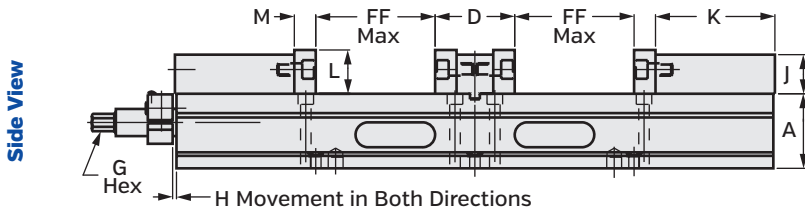
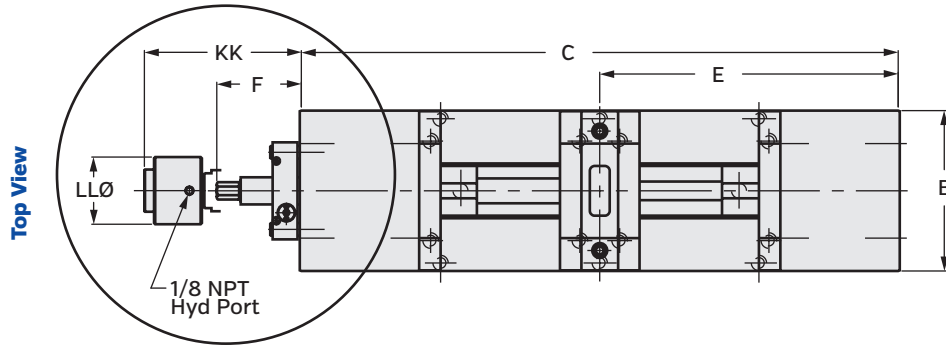

Dimensional Data		
	DL800	DLH800
A	3.750	3.750
B	8.060	8.060
C	30.000	30.000
D	4.000	4.000
E	15.000	15.000
F	4.250	N/A
G	3/4	7/16 - INT
H	0.190	0.190
J	1.965	1.965
K	6.000	6.000
L	2.200	2.200
M	1.075	1.075
N	1.220	1.220
O	4.750	4.750
P	5/8-11	5/8-11
Q	0.750	0.750
R	2.375	2.375
S	1/2-13	1/2-13
S1	5/8-11	5/8-11
T	7.250	7.250
U	7.000	7.000
V	8.000	8.000
W	0.750	0.750
AA	2.500	2.500
BB	5.000	5.000
CC	1.000	1.000
DD	8.500	8.500
EE	1/2	1/2
FF	6.000	6.000
GG	8.925	8.925
HH	13.075	13.075
JJ	16.000	16.000
KK	-	6.49
Weight	250	360
Hyd Displacement Cu. In.	-	2.36

Vise Clamping Force-Lbs.		
Manual torque Ft.-Lbs.	DL800	
10	-	
20	2,023	
30	-	
40	3,578	
50	-	
60	5,136	
70	-	
80	6,883	
100	8,997	

Vise Clamping Force-Lbs.		
Hydraulic PSI Max.	DLH800	
400	1,575	
800	3,150	
1,200	4,725	
1,600	6,300	
2,000	7,875	
2,400	9,450	

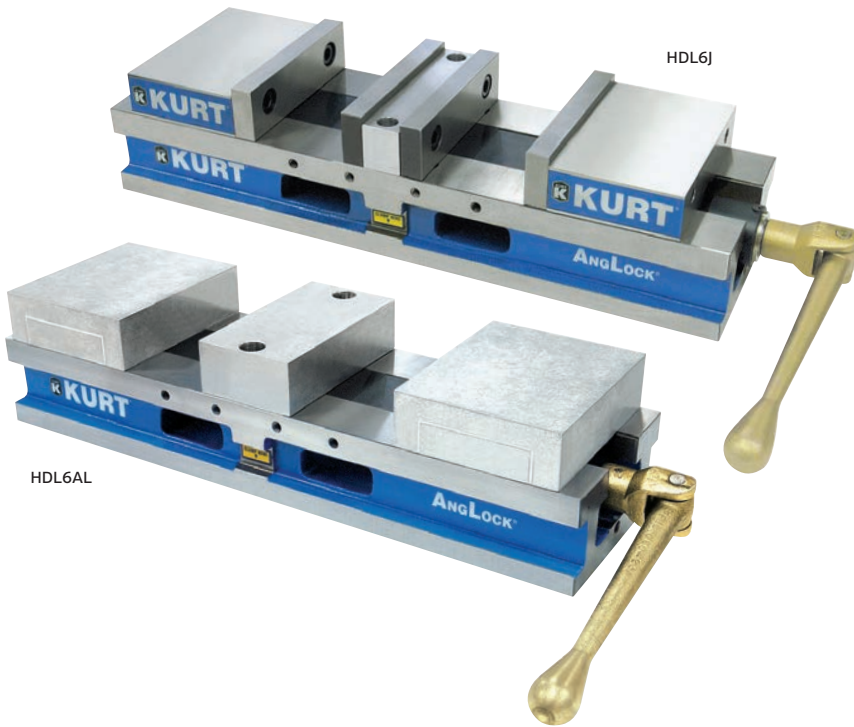

HDL AngLock® Vises

Manual & Hydraulic

4 Inch Base Models:
 HDL4 Manual English
 HDHL4 Hydraulic
 HDLM4 Manual Metric
 HDHLM4 Hydraulic

6 Inch Base Models:
 HDL6 Manual English
 HDHL6 Hydraulic
 HDLM6 Manual Metric
 HDHLM6 Hydraulic

The HDL AngLock Vises are high density long vises with two clamping stations. They provide repeatable clamping to 0.0002" and combine high density with heavy duty features. Designed on a rugged 80,000 PSI ductile iron body with steel components, both models provide strength, rigidity and long term accuracy while absorbing machining vibration.

For specific model numbers see page 48

Features:

- Two clamping stations – repeatable clamping to 0.0002".
- Full 3 and 4 inch opening in each station with standard hard jaw system.
- Quick change jaws
- Jaws are indexable 180 degrees.
- Manual and hydraulic models available.
- Fast easy conversion between manual and hydraulic models. Part #HDHLM4-3-SA-KIT [4 inch] & #HDHLM6-3-SA-KIT [6 inch]
- Maximizes the number of parts in the work envelope.
- Adjustable pre-load feature allows you to minimize pre-load range thus reducing the turns of the handle to open or close the vise (manual version).
- Holding block features the ability to clamp same or dissimilar sized parts and provides pre-loading ability in the front or back jaw (manual version).
- Lifetime Iron Clad Warranty.
- Bed height tolerance $\pm 0.001"$.
- Patented
- Optional clutchless design available for lower clamp force applications. Call factory.

Bottom View
(Mounting hole pattern is designated by color code)

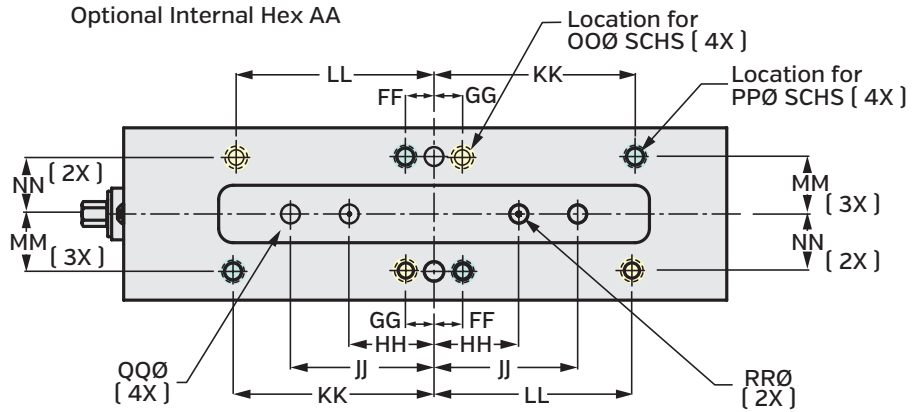
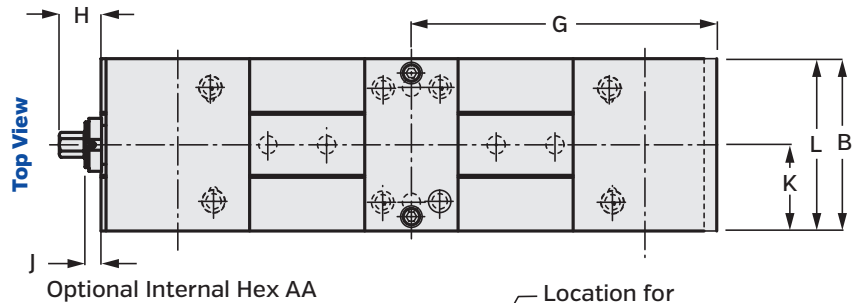

Vise Mounting Options - See page 80

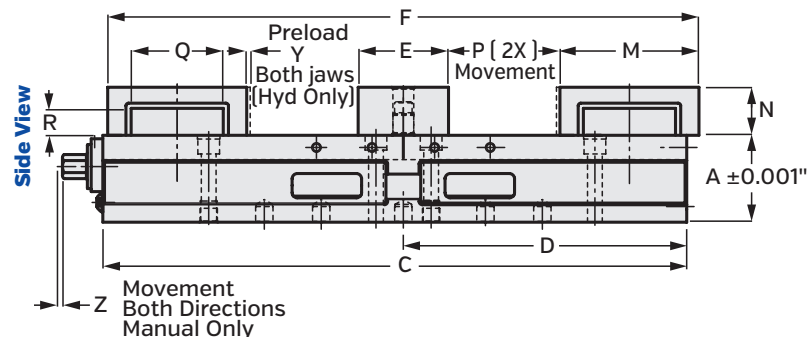

Torque- Ft. Lbs.	Clamping Force Lbs.					
	HDLM4 HDL4	Hydraulic PSI	HDHLM4 HDHL4	HDLM6	Hydraulic PSI	HDHLM6 HDHL6
10	1,040	1,000	775	1,540	500	875
20	2,125	1,500	1,450	2,520	1,000	1,600
30	3,140	2,000	1,900	3,350	1,500	2,330
40	4,040	2,500	2,550	4,310	2,000	3,130
50	4,980	3,000	3,100	5,750	2,500	3,950
60	5,870	3,500	3,700	6,860	3,000	4,750
		4,000	4,200	7,460	3,500	5,475
		4,500	4,800		4,000	6,350
					4,500	7,100
	Hyd. Displacement 0.414 cubic inches			Hyd. Displacement 1.08 cubic inches		

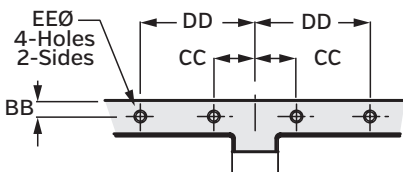
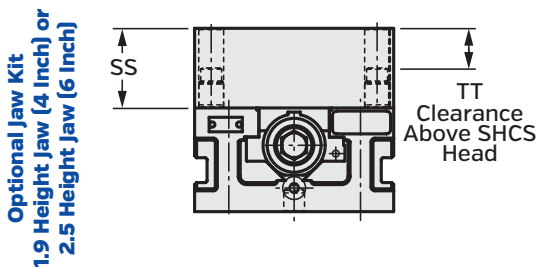
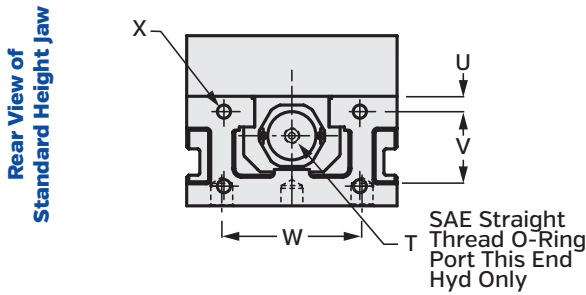
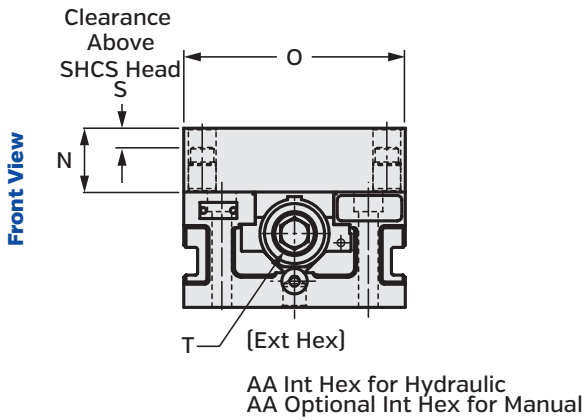

	Dimensional Data							
	High Density 4" & 6" Full OpenVise HDL Manual & Hydraulic							
	HDLM4 / HDL4		HDHLM4 / HDHL4		HDLM6 / HDL6		HDHLM6 / HDHL6	
	mm	Inch	mm	Inch	mm	Inch	mm	Inch
A	60.325	2.375	60.325	2.375	79.375	3.125	79.375	3.125
B	101.600	4.000	101.600	4.000	152.400	6.000	152.400	6.000
C	415.925	16.375	415.925	16.375	533.400	21.000	533.400	21.000
D	200.025	7.875	200.025	7.875	258.877	10.192	258.877	10.192
E	63.500	2.500	63.500	2.500	82.550	3.250	82.550	3.250
F	418.287	16.468	418.287	16.468	539.750	21.250	539.750	21.250
G	209.144	8.234	209.144	8.234	269.875	10.625	269.875	10.625
H	33.680	1.326	-	-	36.830	1.450	-	-
J	9.855	0.388	-	-	21.844	0.860	-	-
K	41.275	1.625	41.275	1.625	63.500	2.500	63.500	2.500
L	82.550	3.250	82.550	3.250	127.000	5.000	127.000	5.000
M	101.600	4.000	101.600	4.000	127.000	5.000	127.000	5.000
N	35.560	1.400	35.560	1.400	43.891	1.728	43.891	1.728
O	101.600	4.000	101.600	4.000	152.400	6.000	152.400	6.000
P	75.794	2.984	75.794	2.984	101.600	4.000	101.600	4.000
Q	65.075	2.562	65.075	2.562	84.125	3.312	84.125	3.312
R	20.625	0.812	20.625	0.812	24.613	0.969	24.613	0.969
S	7.722	0.304	7.722	0.304	13.259	0.522	13.259	0.522
T	14.275 Ext. Hex	9/16 Ext. Hex	7/16 - 20 UNF O-Ring Port	7/16 - 20 UNF O-Ring Port	19.050 Ext. Hex	3/4 Ext. Hex	7/16-20 UNF O-Ring Port	7/16-20 UNF O-Ring Port
U	9.525	0.375	9.525	0.375	11.125	0.438	11.125	0.438
V	42.875	1.688	42.875	1.688	53.975	2.125	53.975	2.125
W	63.500	2.500	63.500	2.500	98.425	3.875	98.425	3.875
X	M8 x 1.25	M8 x 1.25	M8 x 1.25	M8 x 1.25	M10 x 1.5	M10 x 1.5	M10 x 1.5	M10 x 1.5
Y	-	-	3.175	0.125	-	-	3.175	0.125
Z	3.048	0.120	-	-	3.962	0.156	-	-
AA	11.099 Int. Hex	7/16 Int. Hex	11.900 Int. Hex	0.437 Int. Hex	15.875 Int. Hex	5/8 Int. Hex	15.875 Int. Hex	5/8 Int. Hex
BB	9.525	0.375	9.525	0.375	11.125	0.438	11.125	0.438
CC	34.325	1.375	34.325	1.375	33.020	1.300	33.020	1.300
DD	65.100	2.563	65.100	2.563	58.420	3.300	58.420	3.300
EE	M8 x 1.25	5/16-18	M8 x 1.25	5/16-18	M8 x 1.25	5/16-18	M8 x 1.25	5/16-18
FF	-	0.750	-	0.750	-	1.000	-	1.000
GG	20.000	-	20.000	-	25.000	-	25.000	-
HH	100.000	-	100.000	-	75.000	-	75.000	-
JJ	-	5.250	-	5.250	-	5.000	-	5.000
KK	-	5.250	-	5.250	-	7.000	-	7.000
LL	100.000	-	100.000	-	175.000	-	175.000	-
MM	-	1.500	-	1.500	-	2.000	-	2.000
NN	40.000	-	40.000	-	50.000	-	50.000	-
OO	M8 SHCS	-	M8 SHCS	-	M12 SHCS	-	M12 SHCS	-
PP	-	5/16 SHCS	-	5/16 SHCS	-	1/2 SHCS	-	1/2 SHCS
QQ	-	0.625	-	0.625	-	0.625	-	0.625
RR	16.000	-	16.000	-	16.000	-	16.000	-
SS	48.260	1.900	48.260	1.900	60.960	2.400	60.960	2.400
TT	20.422	0.804	20.422	0.804	30.328	1.194	30.328	1.194
	34 Lbs/15.42 Kgs		33 Lbs/14.96 Kgs		32.21 Kgs/71 Lbs		31.75 Kgs/70 Lbs	
	Estimated Weight of Vise Body Only							

HD & HDL Jaw Kits & Fixture Plates See Pages 44-47

HD CarvLock® Manual Short Vises

Model: HDM6AL Manual

The HD CarvLock Vises are High-Density and Heavy-Duty. The overall vise is very compact, making possible maximum density workholding across the full range of today's machining centers. The HD Vise can be equipped with quick change jaws in aluminum, cast iron or with a fixture plate.

Features:

- Compact size. Overall length of just 13.750" and overall width of only 6".
- Clamping power/accuracy - produces up to 7,800 Lbs of clamping force with repeatable clamping to 0.0002".
- Durability - 80,000 PSI ductile iron vise body for rugged strength, rigidity and long-term accuracy while absorbing machining vibration.
- Enclosed vise body keeps out chips and contaminants - makes cleanup fast and easy.
- Fast, easy conversion from manual to hydraulic. Easy to switch between both styles. Part No. HDHM6-3-SA-KIT.
- Jaws are indexable 180 degrees.
- Quick change jaws
- Lifetime Iron Clad Warranty.

The HDM6 Manual vise body has optional jaw systems which include a set of 7075 T-6 aluminum jaw blocks or a set of ductile iron jaw blocks [1.73" standard thickness, 2.40" optional thickness] or fixture plate. Screw and nut assemblies are reversible with the vise body. One jaw kit will handle two different parts.



HDM6AL (shown with optional machinable aluminum jaws)

HD CarvLock® Hydraulic Short Vises

Model: HDHM6AL Hydraulic

Single acting hydraulic vise uses hydraulic pressure to clamp and spring pressure to unclamp. Extremely reliable operation compared to other vises using mechanical operation for unclamping. Designed for automated systems.

Features:

- Well suited for automation.
- Fast, positive open/close cycle.
- Compact size - overall length of just 13.750" and overall width of only 6".
- Clamping power/accuracy - produces up to 7,800 Lbs clamping force @ 5,000 PSI of hydraulic pressure with repeatable clamping to 0.0002".
- Durability - 80,000 PSI ductile iron vise body for rugged strength, rigidity and long-term accuracy while absorbing machining vibration.
- Enclosed vise body keeps out chips and contaminants - makes cleanup fast and easy.
- Jaws are indexable 180 degrees.
- Quick change jaws
- Lifetime Iron Clad Warranty.

The HDHM6 Hydraulic vise body has optional jaw systems which include a set of 7075 T-6 aluminum jaw blocks or a set of ductile iron jaw blocks [1.73" standard thickness, 2.40" optional thickness] or fixture plate. Screw and nut assemblies are reversible with the vise body. One jaw kit will handle two different parts.



HDHM6AL (shown with optional machinable aluminum jaws)

For specific model numbers see page 48

HD & HDL Jaw Kits & Fixture

Plates See Pages 44-47

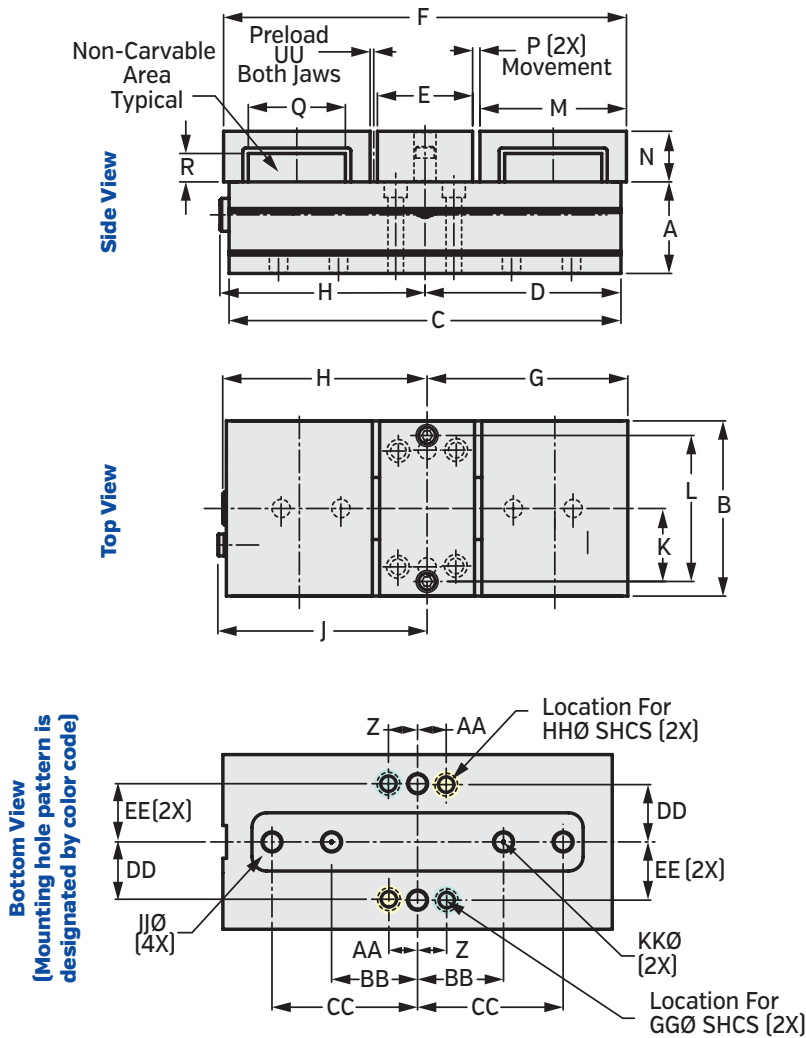

Vise Mounting Options - See page 80

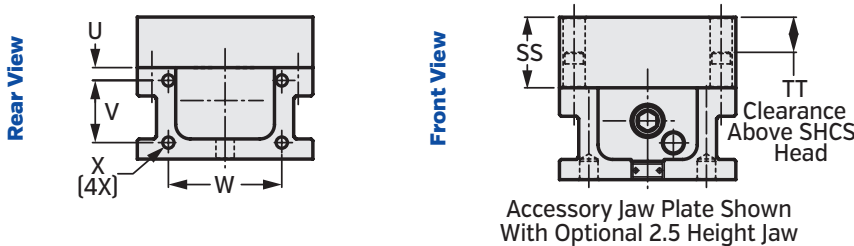

	Dimensional Data High Density 6" HD Vise Manual & Hydraulic			
	HDM6		HDHM6	
	mm	Inch	mm	Inch
A	79.375	3.125	79.375	3.125
B	152.400	6.000	152.400	6.000
C	339.725	13.375	339.725	13.375
D	169.875	6.688	169.875	6.688
E	82.550	3.250	82.550	3.250
F	349.250	13.750	349.250	13.750
G	174.625	6.875	174.625	6.875
H	177.800	7.000	174.630	6.875
J	182.040	7.167	-	-
K	63.500	2.500	63.500	2.500
L	127.000	5.000	127.000	5.000
M	127.000	5.000	127.000	5.000
N	43.891	1.728	43.891	1.728
O	152.400	6.000	152.400	6.000
P	6.350	0.250	6.350	0.250
Q	84.120	3.312	84.120	3.312
R	24.610	0.969	24.610	0.969
S	13.260	0.522	13.260	0.522
T	15.875 Int. Hex	0.625 Int. Hex	7/16-20 UNF O-Ring Port	7/16-20 UNF O-Ring Port
U	11.125	0.438	11.125	0.438
V	53.975	2.125	53.975	2.125
W	98.43	3.875	98.43	3.875
X	M10 x 1.5	M10 x 1.5	M10 x 1.5	M10 x 1.5
Z	1.000	1.000	1.000	1.000
AA	25.000	-	25.000	-
BB	75.000	2.953	75.000	2.953
CC	127.000	5.000	127.000	5.000
DD	50.000	-	50.000	-
EE	2.000	2.000	2.000	2.000
GG	5/8-18	1/2	5/8-18	1/2
HH	-	-	-	-
JJ	15.875	0.625	15.875	0.625
KK	16.000	0.630	16.000	0.630
LL	77.770	3.062	82.550	3.250
MM	90.470	3.562	95.250	3.750
NN	23.830	0.938	23.830	0.938
OO	18.540	0.730	18.540	0.730
PP	30.630	1.206	30.630	1.206
QQ	331.770	13.062	336.550	13.250
RR	344.470	13.562	349.250	13.750
SS	60.960	2.400	60.960	2.400
TT	30.330	1.190	30.330	1.190
UU	-	-	3.180	0.125
VV	7.92	0.312	4.78	0.188

Estimated Weight of Vise Body Only 21.8 Kgs [48 Lbs]

Convertible Kits for Optional Machinable Jaws - Part Number HDM6-CONVKIT

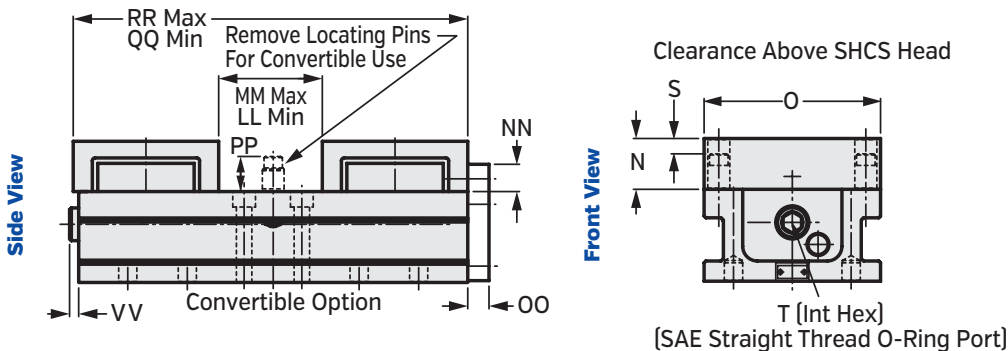

Torque-Ft. Lbs.	Clamping Force Lbs.		
	HDM6	Hydraulic PSI	HDHM6
10	883	500	875
20	1,684	1,000	1,600
30	2,503	1,500	2,330
40	3,187	2,000	3,130
50	3,963	2,500	3,950
60	4,837	3,000	4,750
70	5,556	3,500	5,475
		4,000	6,350
		4,500	7,100
		5,000	7,800

Hyd. Displacement 1.08 cubic inches

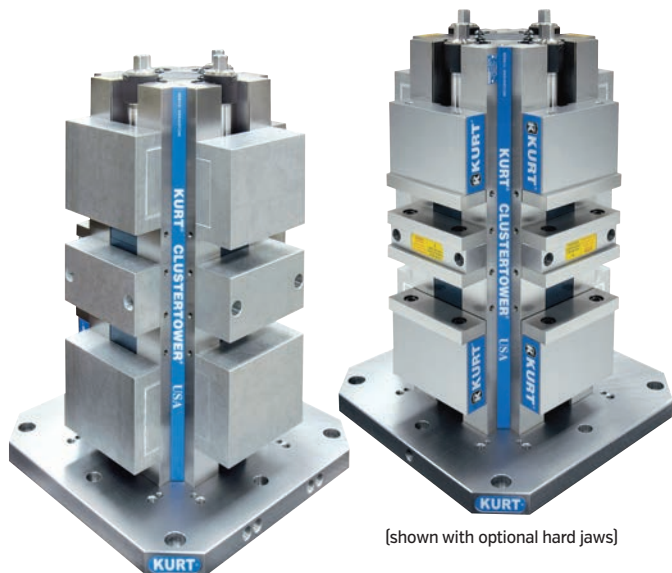

[shown with optional aluminum jaws]

[shown with optional hard jaws]

4 Inch Base Models:

CTHDL443 English	CTHDLM443 Metric
CTHDL444 English	CTHDLM444 Metric
CTHDL445 English	CTHDLM445 Metric

6 Inch Base Models:

CTHDL644 English	CTHDLM644 Metric
CTHDL645 English	CTHDLM645 Metric
CTHDL646 English	CTHDLM646 Metric

HDL CarvLock® Towers

Manually or Hydraulically operated, eight station HDL Cluster Tower system features a ductile iron integral vise tower. Designed for use on mid-size and larger machining centers including horizontal and vertical machining centers with a fourth axis and indexable tables. This workholding system achieves workpiece immobility while damping cutter induced vibration.

Features:

- High density vise tower system. Hold multiple parts in eight clamping stations. Increase part volume.
- Repeatability clamping to 0.0002". 4 inch model delivers up to 5,870 Lbs. each station at 60 Ft Lbs of torque. 6 inch model delivers up to 7,460 Lbs. of clamping force at 70 Ft Lbs of torque.
- Self-adjusting holding block of either front or back jaw for clamping the same or dissimilar sized parts. To further enhance fast operation, an adjustable pre-load feature reduces handle turns for opening and closing clamping stations.
- Ductile iron column ensures strength, rigidity and long term accuracy.
- Jaw options available to fit your application. Select from Hard jaws, Machinable aluminum jaws, Machinable ductile Iron jaws. See Pages 44-47.
- Jaws are indexable 180 degrees.
- Aluminum fixture plate available See pages 46-47.
- Elevated column makes clearing chips and contaminants fast and easy.
- Lifetime Iron Clad Warranty.
- Optional clutchless design available for lower clamp force applications. Call factory.

For specific model numbers see page 48

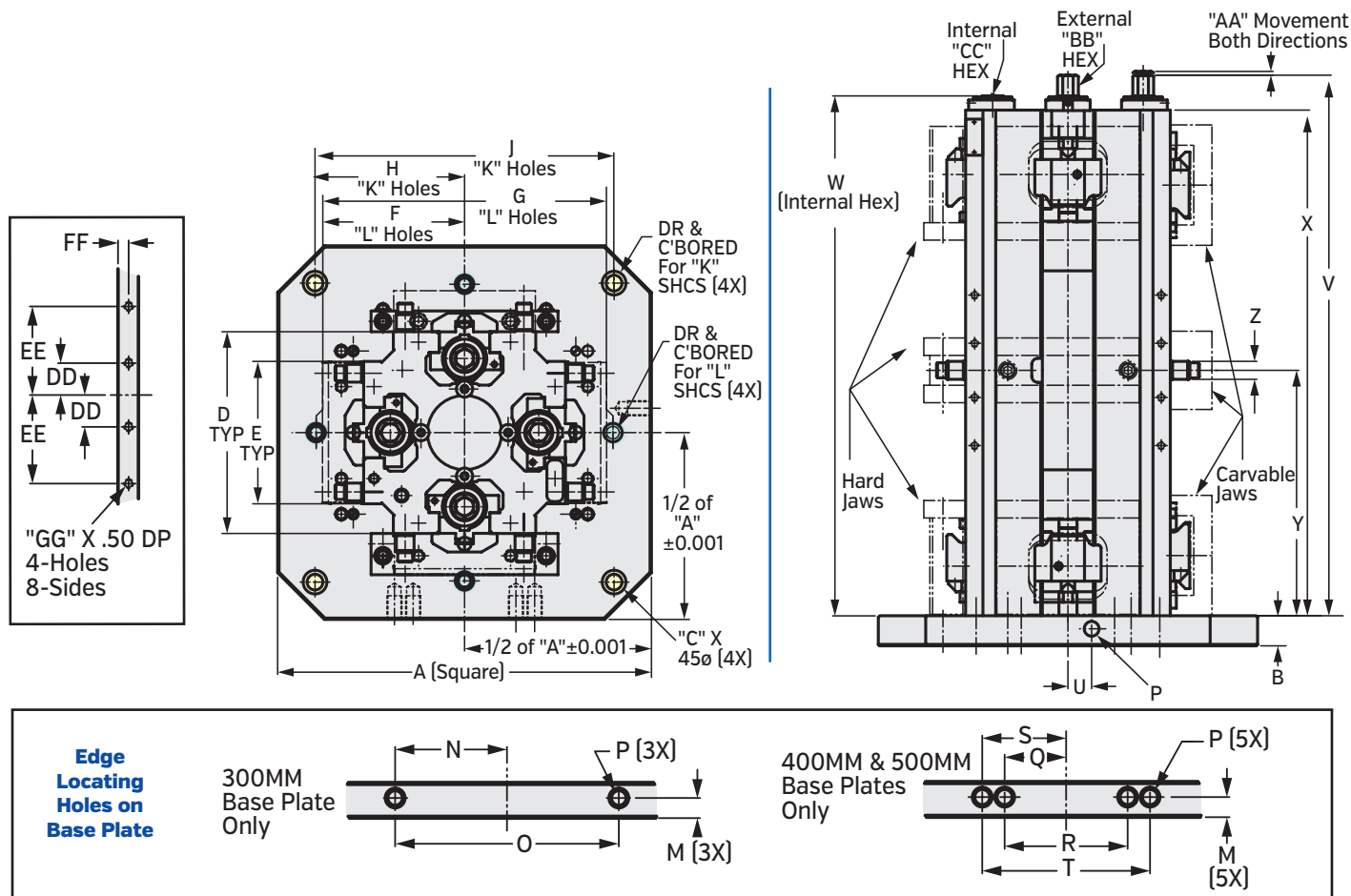

Clamping Force Lbs.		
Torque-Ft. Lbs.	HDL(M)4	HDL(M)6
10	1,040	1,540
20	2,125	2,520
30	3,140	3,350
40	4,040	4,310
50	4,980	5,750
60	5,870	6,860
70		7,460

Clamping Force Lbs.		
Hydraulic PSI	HDHL(M)4	HDHL(M)6
500		875
1,000	775	1,600
1,500	1,450	2,330
2,000	1,900	3,130
2,500	2,550	3,950
3,000	3,100	4,750
3,500	3,700	5,475
4,000	4,200	6,350
4,500	4,800	7,100
	Hyd. Displacement per screw 1.08 cubic inches	

Base Dimensional Data HDL Long Cluster Tower													
	CTHDL(M)44		CTHDL(M)64		300MM Base		400MM Base		500MM Base		630MM Base		
	mm	Inch	mm	Inch	mm	Inch	mm	Inch	mm	Inch	mm	Inch	
A					300	11.811	400	15.748	500	19.685	630	24.803	
B					25.4	1	31.75	1.25	31.75	1.25	38.1	1.5	
C					20	0.79	50	1.97	60	2.36	70	2.76	
D					158.75	6.25	158.75	6.25	158.75	6.25	215.9	8.5	
E					101.6	4	101.6	4	101.6	4	152.4	6	
F					-	-	158.75	6.25	203.2	8	254	10	
G					-	-	317.5	12.5	406.4	16	508	20	
H					127	5	160	6.299	200	7.874	250	9.842	
J					254	10	320	12.598	400	15.748	500	19.685	
K					M12 SHCS	-	M16 SHCS	-	M16 SHCS	-	M16 SHCS	-	
L					-	1/2 SHCS	-	1/2 SHCS	-	1/2 SHCS	-	1/2 SHCS	
M					15	0.59	18	0.709	18	0.709	18	0.790	
N					40	1.575	-	-	-	-	200	3.937	
O					80	3.15	-	-	-	-	100	7.874	
P					M12 x 1.75	-	M16 x 2.0	-	M16 x 2.0	-	M16 x 2.0	-	
Q					-	-	55	2.165	55	2.165	-	-	
R					-	-	110	4.33	110	4.33	-	-	
S					-	-	75	2.953	75	2.953	-	-	
T					-	-	150	5.906	150	5.906	-	-	
U					-	-	25	0.984	25	0.984	25	0.984	
V	449.6	17.701	570.23	22.45									
W	425.78	16.763	548.38	21.59									
X	415.92	16.375	533.4	21									
Y	200.03	7.875	258.88	10.192									
Z	15	0.59	19.05	0.75									
AA	3.05	0.12	3.95	0.156									
BB	14.28	0.562	19.05	0.750									
CC	11.1	0.437	15.87	0.625									
DD	34.92	1.375	28.58	1.125									
EE	65.1	2.563	79.38	3.125									
FF	9.53	0.375	9.53	0.375									
GG	M8 x 1.25	M8 x 1.25	M8 x 1.25	M8 x 1.25									
Base Weight		119 Lbs		270 Lbs		39 Lbs		85 Lbs		133 Lbs		255 Lbs	

Center Locator Part #36V2T400-277-2

Ask about our
12 Station
HD CarvLock Towers

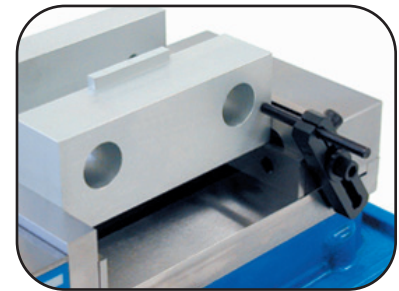
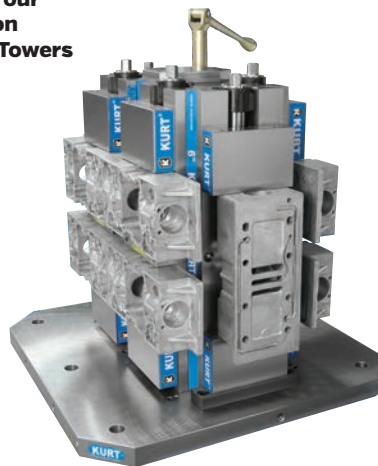

HD & HDL jaw Kits & Fixture Plates See Pages 44-47

6AWS and 6AWSM Workstop, page 74

HD CarvLock® Towers

Base Model: CTHDM64 (Manual)

For specific model numbers see page 48.

This manually operated, eight station HD Cluster Tower system features a cast iron integral vise tower. Ideal for horizontal machining centers or vertical machining centers with indexable tables. This workholding system achieves workpiece immobility while damping cutter induced vibration.

Features:

- Most compact, high density vise tower system in the industry.
- Hold multiple parts in eight clamping stations. Increase part volume.
- Small footprint which reduces spindle travel, part to part, maximizing throughput without compromising holding accuracy.
- Ductile iron column insures strength, rigidity and long term accuracy.
- Jaw options available to fit your application. Select from Machinable aluminum jaws, Machinable ductile Iron jaws and Aluminum fixture plate.
- Jaws are indexable 180 degrees.
- Base sizes available include: 300mm, 400mm, 500mm, 630mm.
- Elevated column makes clearing chips and contaminants fast and easy.
- Lifetime Iron Clad Warranty.

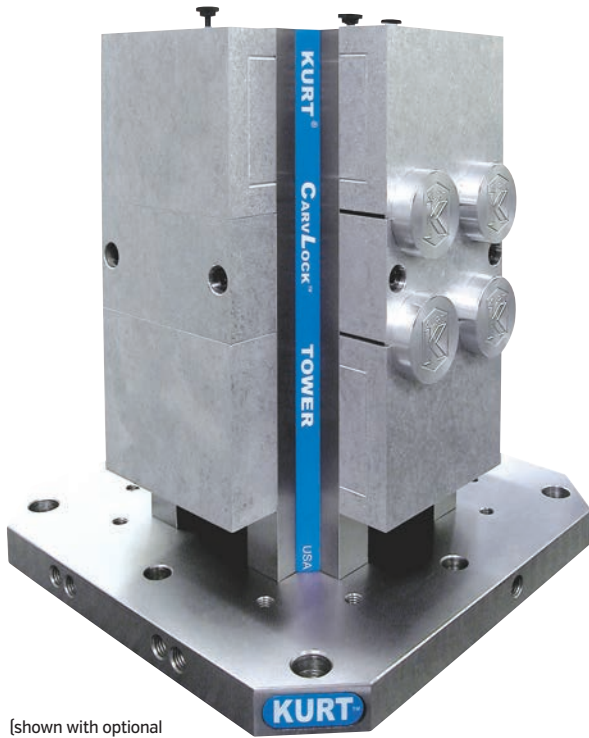

[shown with optional machinable aluminum jaws]

HD CarvLock® Towers

Base Model: CTHDHM64 (Hydraulic)

For specific model numbers see page 48.

Identical in capacity and features as the manual HD CarvLock Tower system, this system is actuated hydraulically. Hydraulic piston is an integral part of the vise nut within the vise and tower body to conserve valuable space on the machine table. This hydraulic version also shares all of the jaw options and other accessories which are available in the manual version. Hydraulic pump and hose not included.

Features:

- Up to 7,800 pounds of clamping force.
- Jaw options available to fit your application. Select from Machinable aluminum jaws, Machinable ductile Iron jaws and Aluminum fixture plate.
- Jaws are indexable 180 degrees.
- Elevated column makes clearing chips and contaminants fast and easy.
- Base sizes available include: 300mm, 400mm, 500mm, 630mm.
- Lifetime Iron Clad Warranty.

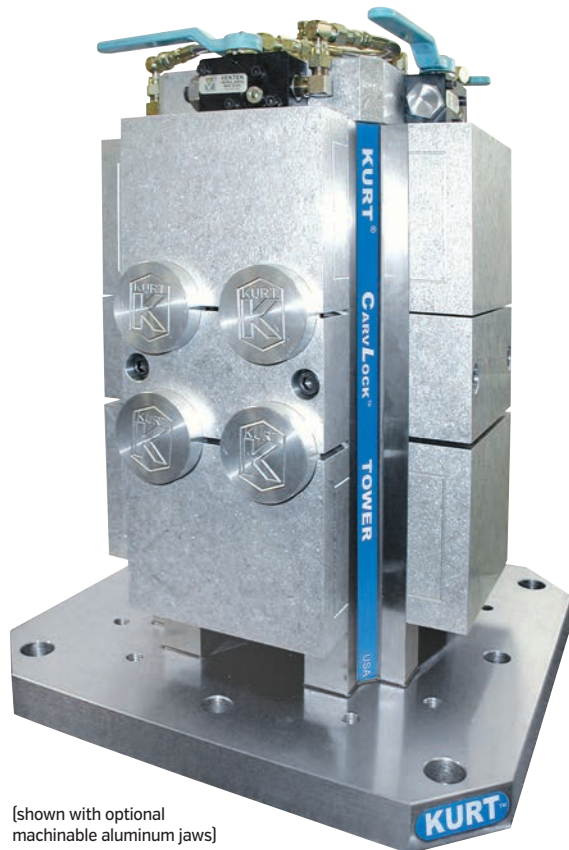

[shown with optional machinable aluminum jaws]

CTHDHM64 Specifications see page 42

Clamping Force Lbs.	
Torque-Ft. Lbs.	HDM6
10	883
20	1,684
30	2,503
40	3,187
50	3,963
60	4,837
70	5,556

	HD Manual Tower Dimensions							
	CTHDM643		CTHDM644		CTHDM645		CTHDM646	
	mm	Inch	mm	Inch	mm	Inch	mm	Inch
A	300.000	11.811	400.000	15.748	500.000	19.685	630.000	24.803
B	25.400	1.000	31.750	1.250	31.750	1.250	38.100	1.500
C	20.000	0.787	50.000	1.969	60.000	2.362	70.100	2.760
D	215.900	8.500	215.900	8.500	215.900	8.500	215.900	8.500
E	152.400	6.000	152.400	6.000	152.400	6.000	152.400	6.000
F	-	-	158.750	6.250	203.200	8.000	254.000	10.000
G	-	-	317.500	12.500	406.400	16.000	508.000	20.000
H	127.000	5.000	160.000	6.299	200.000	7.874	250.000	9.843
J	254.000	10.000	320.000	12.598	400.000	15.748	500.000	19.685
K	M12	M12	M16	M16	M16	M16	M16	M16
L	-	-	M12	M12	M12	M12	M12	M12
M	15.000	0.591	18.000	0.709	18.000	0.709	18.000	0.709
N	40.000	1.575	-	-	-	-	100.000	3.937
O	80.000	3.150	-	-	-	-	200.000	7.874
P	M12 x 1.75	M12 x 1.75	-	-	-	-	M16 x 2.0	M16 x 2.0
Q	-	-	55.000	2.165	55.000	2.165	-	-
R	-	-	110.000	4.331	110.000	4.331	-	-
S	-	-	75.000	2.953	75.000	2.953	-	-
T	-	-	150.000	5.906	150.000	5.906	-	-
U	-	-	M16 x 2.0	M16 x 2.0	M16 x 2.0	M16 x 2.0	-	-
V	-	-	25.000	0.984	25.000	0.984	25.000	0.984
W	403.230	15.875	403.230	15.875	403.230	15.875	403.230	15.875
X	390.520	15.375	390.520	15.375	390.520	15.375	390.520	15.375
Y	220.680	8.688	220.680	8.688	220.680	8.688	220.680	8.688
Z	111.130	4.375	111.130	4.375	111.130	4.375	111.130	4.375
AA	398.480	15.688	398.480	15.688	398.480	15.688	398.480	15.688
BB	47.625	1.875	47.625	1.875	47.625	1.875	47.625	1.875
CC	174.625	6.875	174.625	6.875	174.625	6.875	174.625	6.875
DD	82.550	3.250	82.550	3.250	82.550	3.250	82.550	3.250
EE	92.080	3.625	92.080	3.625	92.080	3.625	92.080	3.625
FF	15.875 Int. Hex	0.625 Int. Hex	15.875 Int. Hex	0.625 Int. Hex	15.875 Int. Hex	0.625 Int. Hex	15.875 Int. Hex	0.625 Int. Hex
Approx. weight Kgs/ Lbs without jaw sets	139.7	308	161.0	355	183.7	405	239.5	528

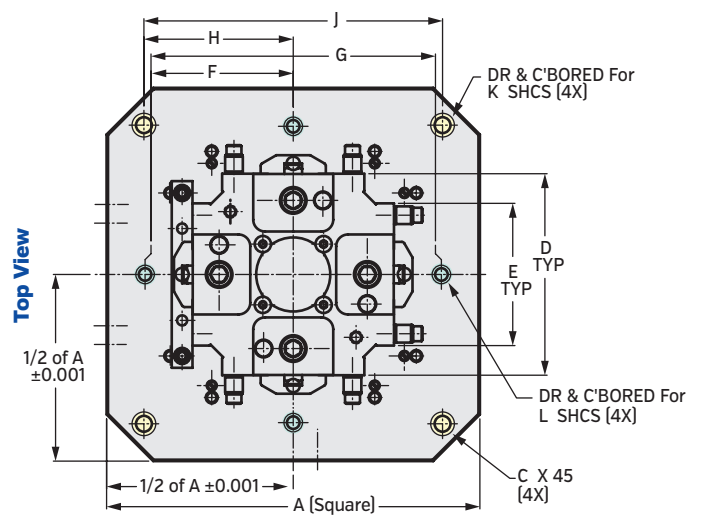
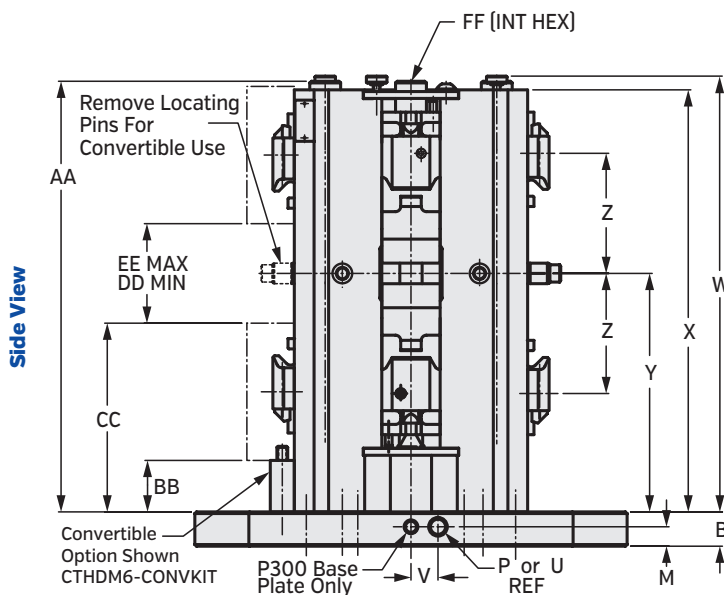
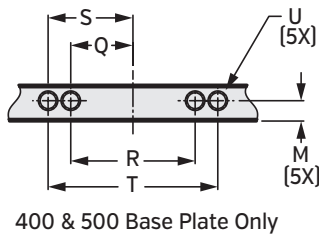
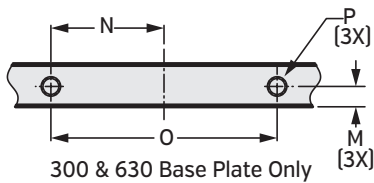

HD & HDL jaw Kits & Fixture Plates See Pages 44-47

HD CarvLock® Towers (Hydraulic)

CTHDHM64 Specifications

	HD Hydraulic Tower Dimensions							
	CTHDHM643		CTHDHM644		CTHDHM645		CTHDHM646	
	mm	Inch	mm	Inch	mm	Inch	mm	Inch
A	300.000	11.811	400.000	15.748	500.000	19.685	630.000	24.803
B	25.400	1.000	31.750	1.250	31.750	1.250	38.100	1.500
C	20.000	0.787	50.000	1.969	60.000	2.362	70.100	2.760
D	215.900	8.500	215.900	8.500	215.900	8.500	215.900	8.500
E	152.400	6.000	152.400	6.000	152.400	6.000	152.400	6.000
F	-	-	158.750	6.250	203.200	8.000	254.000	10.000
G	-	-	317.500	12.500	406.400	16.000	508.000	20.000
H	127.000	5.000	160.000	6.299	200.000	7.874	250.000	9.843
J	254.000	10.000	320.000	12.598	400.000	15.748	500.000	19.685
K	M12	M12	M16	M16	M16	M16	M16	M16
L	-	-	M12	M12	M12	M12	M12	M12
M	15.000	0.591	18.000	0.709	18.000	0.709	18.000	0.709
N	40.000	1.575	-	-	-	-	100.000	3.937
O	80.000	3.150	-	-	-	-	200.000	7.874
P	M12 x 1.75	M12 x 1.75	-	-	-	-	M16 x 2.0	M16 x 2.0
Q	-	-	55.000	2.165	55.000	2.165	-	-
R	-	-	110.000	4.331	110.000	4.331	-	-
S	-	-	75.000	2.953	75.000	2.953	-	-
T	-	-	150.000	5.906	150.000	5.906	-	-
U	-	-	M16 x 2.0	M16 x 2.0	M16 x 2.0	M16 x 2.0	-	-
V	-	-	25.000	0.984	25.000	0.984	25.000	0.984
W	487.170	19.180	487.170	19.180	487.170	19.180	487.170	19.180
X	390.520	15.375	390.520	15.375	390.520	15.375	390.520	15.375
Y	220.680	8.688	220.680	8.688	220.680	8.688	220.680	8.688
Z	127.000	5.000	127.000	5.000	127.000	5.000	127.000	5.000
AA	6.350	0.250	6.350	0.250	6.350	0.250	6.350	0.250
BB	47.625	1.875	47.625	1.875	47.625	1.875	47.625	1.875
CC	174.625	6.875	174.625	6.875	174.625	6.875	174.625	6.875
DD	82.550	3.250	82.550	3.250	82.550	3.250	82.550	3.250
EE	95.250	3.750	95.250	3.750	95.250	3.750	95.250	3.750
FF	82.550	3.250	82.550	3.250	82.550	3.250	82.550	3.250
Approx. weight Kgs/Lbs without jaw sets	148.8	328	170.1	375	192.8	425	248.6	548

Clamping Force Lbs.	
Hydraulic PSI	HDHM6
500	875
1,000	1,600
1,500	2,330
2,000	3,130
2,500	3,950
3,000	4,750
3,500	5,475
4,000	6,350
4,500	7,100
5,000	7,800
Hyd. Displacement Cu. In.	1.08

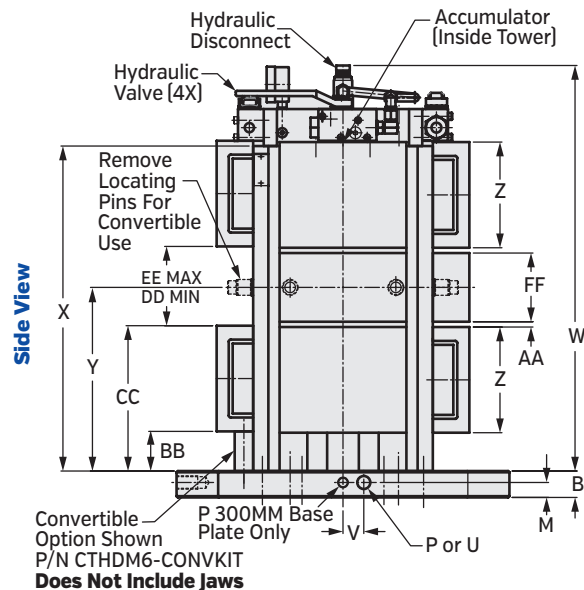
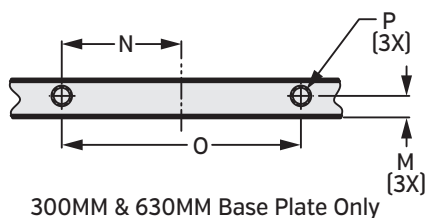
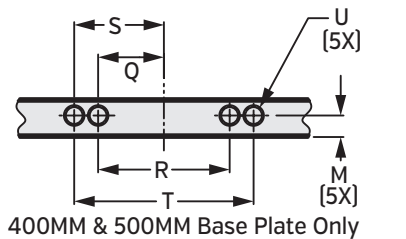
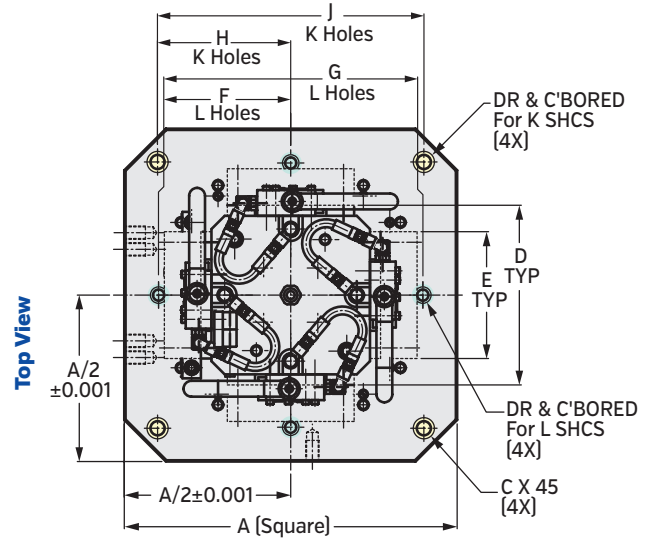
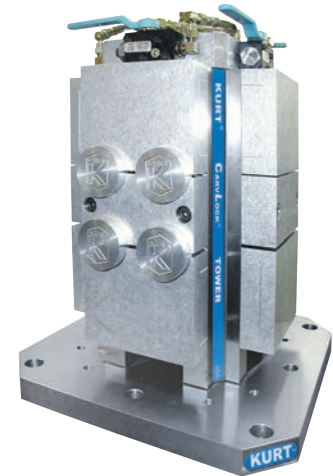

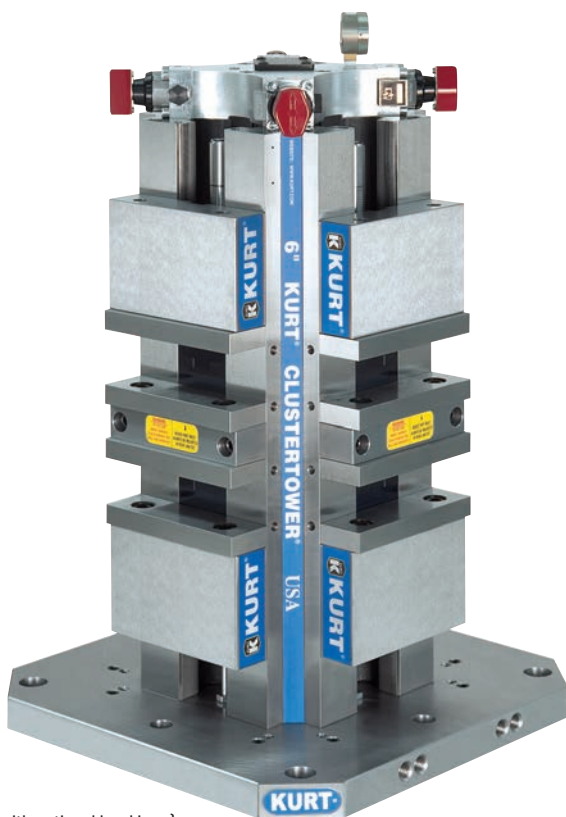

[shown with optional hard jaws]

HDL CarvLock® Towers

CTHDHL64 Hydraulic Tower – English
CTHDHLM64 Hydraulic Tower – Metric

This hydraulically operated eight station tower features all-new design for fast loading of parts. All internalized hydraulic piston/nut saves valuable space. Includes all original KURT AngLock precision clamping and iron rigid construction for damping vibration.

Features:

- Hydraulically operated eight station CTHDHL64 Cluster Tower.
- Utilizes an all internal hydraulic piston nut to conserve space. Pressure is maintained until released by operator or triggering device. Easy disconnect for pallet shuttle.
- Repeatable clamping to 0.0002". Each station delivers up to 7,100 Lbs. of clamping force at 4,500 PSI.
- Each face is controlled separately for convenient part loading and removal.
- Jaw opening is 4" per station.
- Each face has a maximum total stroke of 1/4" [1/8" per station].
- Jaw options available: Hard jaws, machinable aluminum, machinable ductile iron. See pages 40-43
- Base sizes available: 400mm, 500mm, 630mm.
- Lifetime Iron Clad Warranty

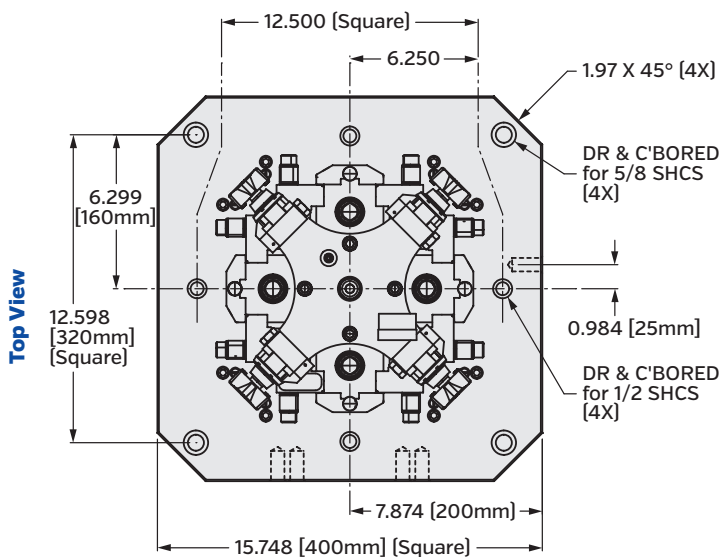
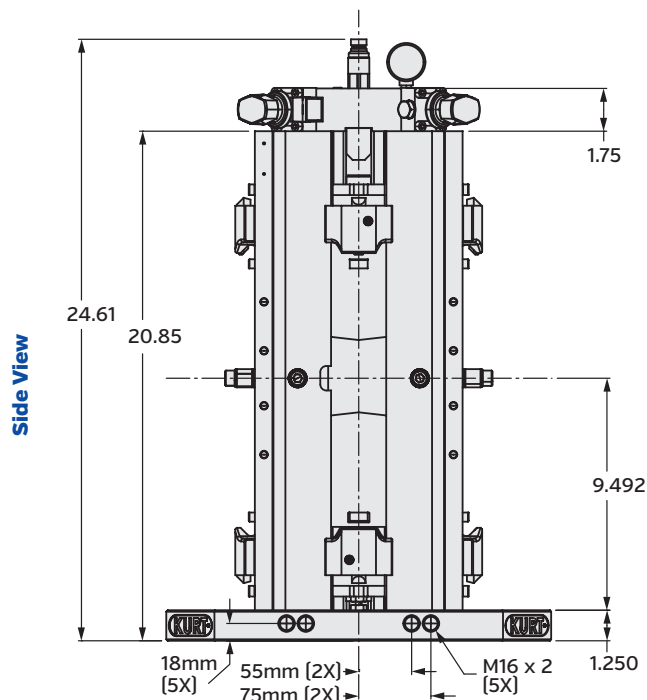

HD & HDL Jaw Kits & Fixture Plates See Pages 44-47

HD & HDL Vises Machinable Jaw Kits

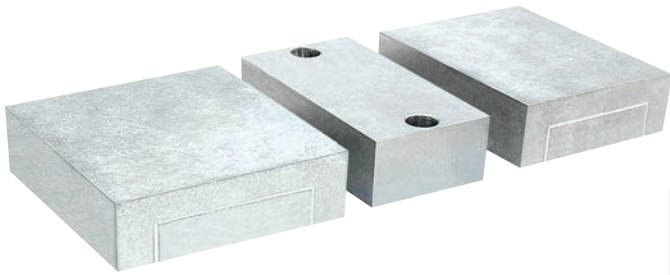

**7075T6 Aluminum and Cast Iron Machinable Jaws
Jaw Kit Dimensional Data for High Density 6" HD & HDL Vises**

	HD6AL Jaw Kit		HD6AL2.5 Jaw Kit		HD6C Jaw Kit	
	mm	Inch	mm	Inch	mm	Inch
A	43.891	1.728	60.960	2.400	43.891	1.728
B	152.400	6.000	152.400	6.000	152.400	6.000
C	127.000	5.000	127.000	5.000	127.000	5.000
D	82.550	3.250	82.550	3.250	82.550	3.250
E	84.120	3.312	84.120	3.312	84.120	3.312
F	24.160	0.951	24.160	0.951	24.160	0.951
G	13.260	0.522	30.330	1.190	13.260	0.522
H	349.250	13.750	349.250	13.750	349.250	13.750
Weight	3 Kgs.	7 Lbs.	9 Kgs.	19 Lbs.	15 Kgs.	33 Lbs.

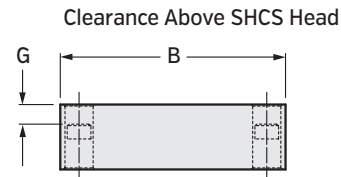
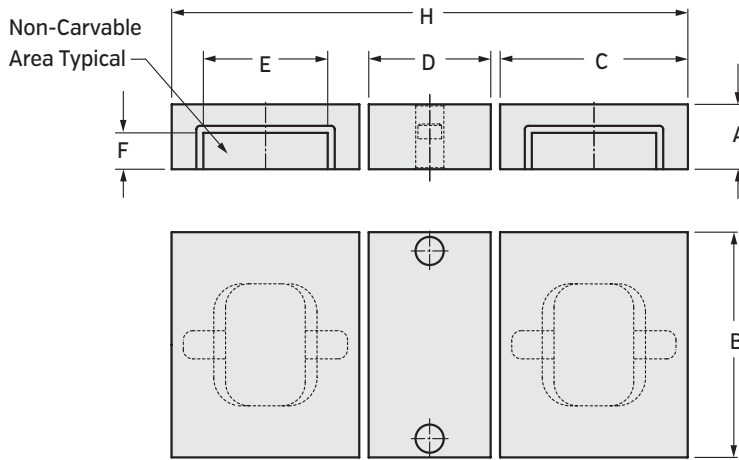

Convertible Options - Dimensional Data for Carvable Jaws

	4" Manual / Hydraulic		6" Manual / Hydraulic	
	mm	Inch	mm	Inch
J	205.968	8.109	274.574	10.810
K	55.880	2.200	77.775	3.062
L	409.168	16.109	528.574	20.810
M	259.080	10.200	331.775	13.062
O	18.262	0.719	23.825	0.938
P	15.240	0.600	15.367	0.605

Convertible Option for Carvable Jaws (Manual Vise Shown) HDLM4-CONVKIT & HDLM6-CONVKIT

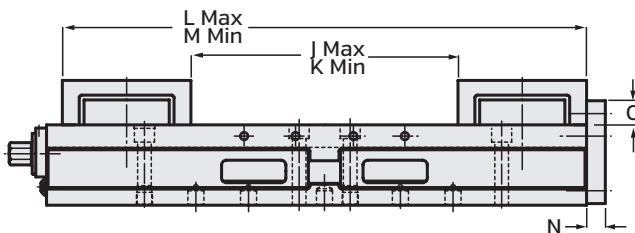

Machinable Jaw Kit Part Numbers			
Part No.	Description	Lbs	Kgs
HDLM4AL-JAWKIT	1.40 High Aluminum Jaw Kit	6	3
HDLM4AL1.9-JAWKIT	1.90 High Aluminum Jaw Kit	8	4
HDLM4C-JAWKIT	1.40 High Iron Jaw Kit	14	7
HD6AL-JAWKIT	1.73 High Aluminum Jaw Kit	14	7
HD6AL2.5-JAWKIT	2.4 High Aluminum Jaw Kit	19	9
HD6C-JAWKIT	1.73 High Iron Jaw Kit	33	15

HDL Vise Hard ("J") Jaw Kits

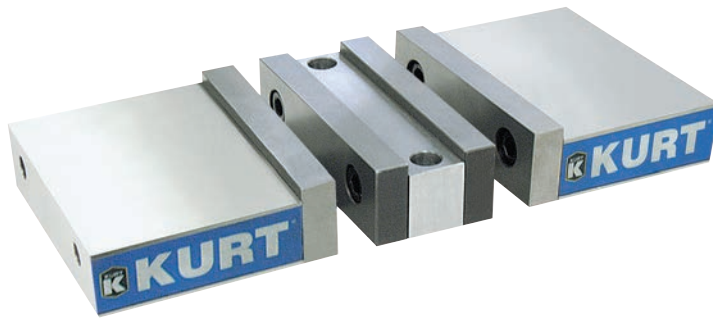

Hardened Jaw Positions
(Manual Vise Shown)

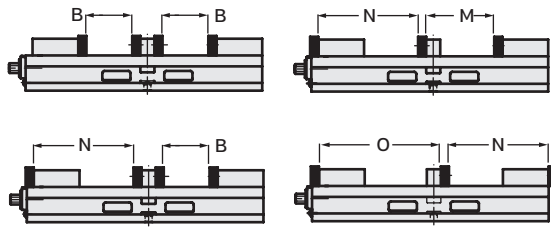

Hardened Jaws
(Manual Vise Shown)

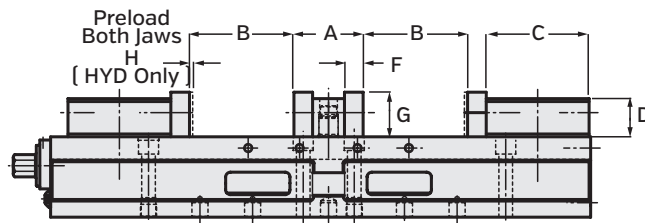

Front View

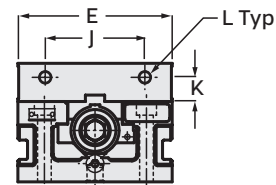

Hardened Jaw Positions
(Manual Vise Shown)

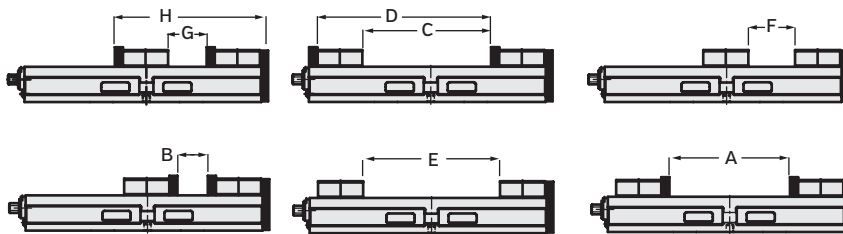

Convertible Option for Hard Jaws
HDLM4J-CONVKIT & HDLM6J-CONVKIT (Manual Vise)

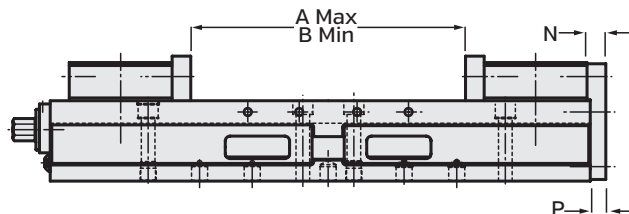

HARD JAW OPTION - DIMENSIONAL DATA

	4" MANUAL HYDRAULIC		6" MANUAL HYDRAULIC	
	mm	Inch	mm	Inch
A	59.538	2.344	68.326	2.690
B	76.200	3.000	101.600	4.000
C	73.812	2.906	101.600	4.000
D	28.321	1.115	37.719	1.485
E	101.600	4.000	152.400	6.000
F	13.894	0.547	18.415	0.725
G	31.369	1.235	44.069	1.735
H	3.175 Hydraulic Only	0.125 Hydraulic Only	3.175 Hydraulic Only	0.125 Hydraulic Only
J	63.500	2.500	98.425	3.875
K	17.450	0.687	23.876	0.940
L	M10 x 1.50	3/8 - 16	M12 x 1.75	1/2 - 13
M	121.844	4.797	151.511	5.965
N	163.906	6.453	221.615	8.725
O	209.550	8.250	271.526	10.690

Hard Jaw Kit Part Numbers

Part No.	Description	Lbs	Kgs
HDL4J-JAWKIT	Inch J Style Hard Jaw Kit	10	5
HDLM4J-JAWKIT	Metric J Style Hard Jaw Kit	10	5
HDL6J-JAWKIT	Inch J Style Hard Jaw Kit	27	13
HDLM6J-JAWKIT	Metric J Style Hard Jaw Kit	27	13

Convertible Options - Dimensional Data for Hard Jaws

	4" Manual / Hydraulic		6" Manual / Hydraulic	
	mm	Inch	mm	Inch
A	211.938	8.344	271.526	10.690
B	59.538	2.344	68.326	2.690
C	225.831	8.891	289.941	11.415
D	299.644	11.797	391.541	15.415
E	239.725	9.438	308.356	12.140
F	87.325	3.438	105.156	4.140
G	73.431	2.891	86.741	3.415
H	147.244	5.797	188.341	7.415
N	20.625	0.812	18.542	0.730
O	18.262	0.719	23.825	0.938
P	15.240	0.600	15.367	0.605

HD & HDL Vise and Tower Fixture Plates Fits HD CarvLock® Vise & CTHD CarvLock® Towers

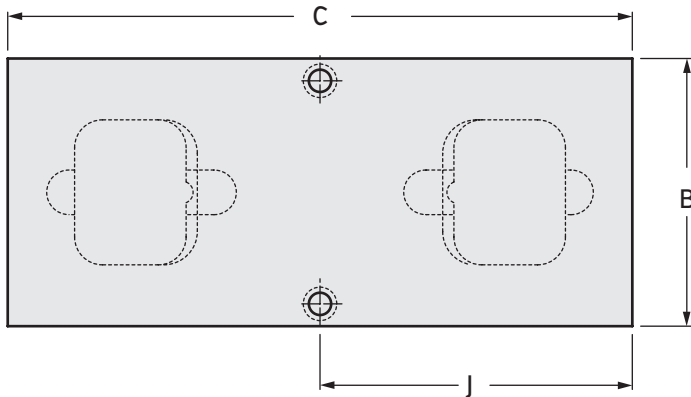

HD6ALP620-239 Fixture Plate		
	mm	Inch
A	50.290	1.980
B	152.400	6.000
C	355.600	14.000
E	84.120	3.312
F	24.610	0.969
J	177.800	7.000
K	62.710	2.469
L	82.550	3.250
Est. Weight	6.4 Kgs	14 Lbs

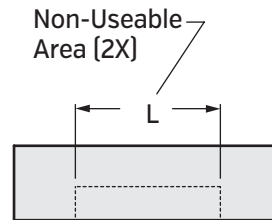
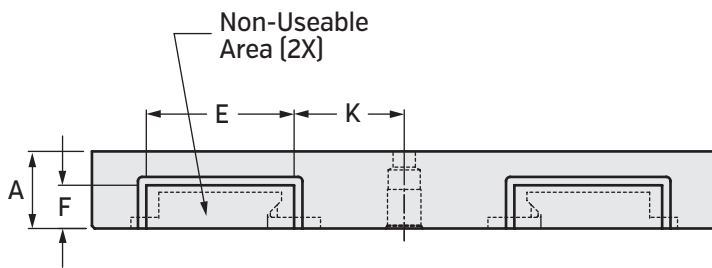

Fits HDL CarvLock® Vise & CTHDL CarvLock® Towers

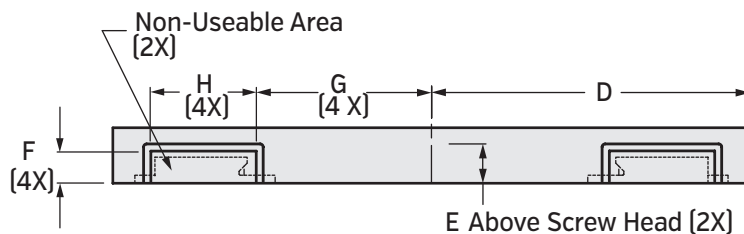
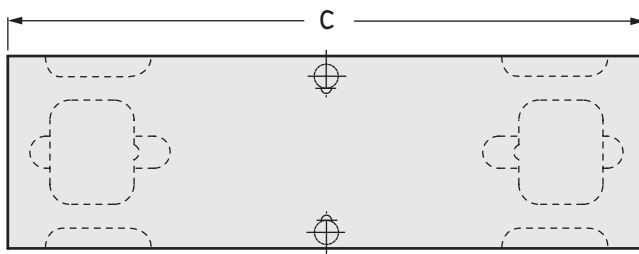

Aluminum Fixture Plate Accessory for HDLM Vise & CTHDLM Tower 4"		
HDLM4ALP419		
	mm	Inch
A	48.26	1.900
B	101.60	4.00
C	393.70	15.500
D	196.85	7.750
E	40.54	1.596
H	20.57	0.810
J	65.07	2.562
K	100.84	3.970
L	65.02	2.560
Est. Weight	2 Kgs	4 Lbs

Aluminum Fixture Plate Accessory for HDLM Vise & CTHDLM Tower 6"		
HDL6ALP619		
	mm	Inch
A	48.260	1.900
B	152.400	6.000
C	508.000	20.000
D	254.000	10.000
E	30.988	1.220
F	24.613	0.969
G	138.938	5.470
H	84.125	3.312
J	82.550	3.250
Est. Weight	5 Kgs	11 Lbs

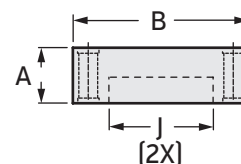

HD & HDL CarvLock® Tower Jaw Kits

Manual & Hydraulic

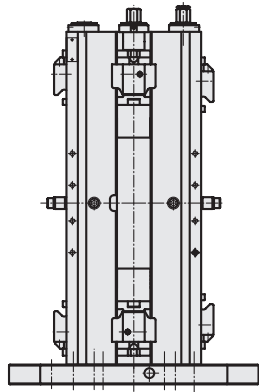

	4 Inch Jaw Accessories					
	Hard Jaws		Machinable Jaws			
	HDLM4J-Jaw Kit		HDLM4AL-Jaw Kit HDLM4C-Jaw Kit		HDLM4AL1.9-Jaw Kit	
	mm	Inch	mm	Inch	mm	Inch
A	59.538	2.344	63.500	2.500	63.500	2.500
B	76.200	3.000	66.675	2.625	66.675	2.625
C	73.812	2.906	101.600	4.000	101.600	4.000
D	28.321	1.115	35.560	1.400	48.260	1.900
E	101.600	4.000	101.600	4.000	101.600	4.000
F	13.894	0.547	-	-	-	-
G	31.369	1.235	-	-	-	-
H	17.450	0.687	-	-	-	-
J	63.500	2.500	-	-	-	-
K	M10 x 1.50	3/8 - 16	-	-	-	-
L	-	-	-	-	-	-
M	-	-	-	-	-	-
N	-	-	-	-	-	-
O	-	-	-	-	-	-
P	-	-	7.722	0.304	20.422	0.804
Q	-	-	20.625	0.812	20.625	0.812
R	-	-	65.075	2.562	65.075	2.562

	6 inch Jaw Accessories					
	Hard Jaws		Machinable Jaws			
	HDLM6J-Jaw Kit		HD6AL-Jaw Kit HD6C-Jaw Kit		HD6AL2.5-Jaw Kit	
	mm	Inch	mm	Inch	mm	Inch
A	68.326	2.690	82.550	3.250	82.550	3.250
B	103.170	4.062	90.630	3.568	90.630	3.568
C	101.600	4.000	127.000	5.000	127.000	5.000
D	37.719	1.485	43.890	1.728	60.960	2.400
E	151.610	5.968	152.400	6.000	152.400	6.000
F	18.415	0.725	-	-	-	-
G	44.069	1.735	-	-	-	-
H	23.876	0.940	-	-	-	-
J	98.425	3.875	-	-	-	-
K	M12 x 1.75	1/2 - 13	-	-	-	-
L	-	-	-	-	-	-
M	-	-	-	-	-	-
N	-	-	-	-	-	-
O	-	-	-	-	-	-
P	-	-	13.260	0.522	30.330	1.194
Q	-	-	24.610	0.969	24.610	0.969
R	-	-	84.120	3.312	84.120	3.312

	4 Inch Jaw Accessories Convertible Option			
	Hard Jaws		Carvable Jaws	
	CTHDLM4J-CONVKIT		CTHDLM4-CONVKIT	
	mm	Inch	mm	Inch
A	-	-	-	-
B	-	-	-	-
C	-	-	-	-
D	-	-	-	-
E	-	-	-	-
F	-	-	-	-
G	-	-	-	-
H	-	-	-	-
J	-	-	-	-
K	-	-	-	-
L	13.894	0.547	13.874	0.547
M	101.600	4.000	115.494	4.547
N	196.850	7.750	169.060	6.656
O	57.150	2.250	57.150	2.250
P	-	-	-	-
Q	-	-	-	-
R	-	-	-	-

	6 Inch Jaw Accessories Convertible Option			
	Hard Jaws		Carvable Jaws	
	CTHDLM6J-CONVKIT		CTHDLM6-CONVKIT	
	mm	Inch	mm	Inch
A	-	-	-	-
B	-	-	-	-
C	-	-	-	-
D	-	-	-	-
E	-	-	-	-
F	-	-	-	-
G	-	-	-	-
H	-	-	-	-
J	-	-	-	-
K	-	-	-	-
L	21.590	0.850	18.415	0.725
M	141.605	5.575	145.415	5.725
N	254.640	10.025	256.540	10.100
O	68.326	2.690	79.760	3.140
P	-	-	-	-
Q	-	-	-	-
R	-	-	-	-

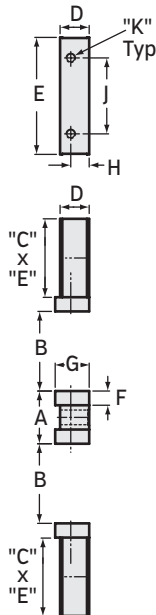

Hard Jaws Typ.

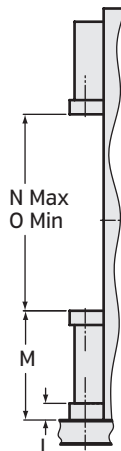

Convertible Option
Shown Hard Jaws Does
Not include jaws

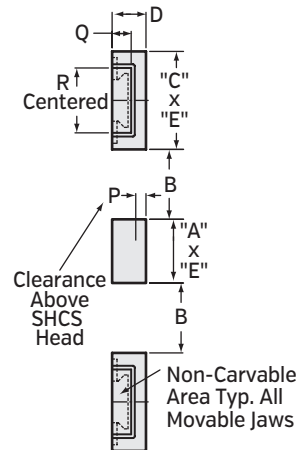

Alum. or Ductile Carvable
Jaws Shown Typ.

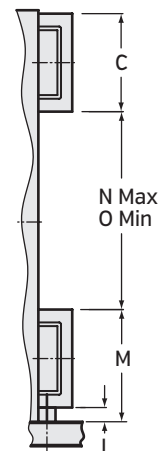

Convertible Option
Shown Carvable Jaws

Cluster Tower Weights Complete With Specific Jaw Or Fixture Plate

	Base Model (No Jaw)	"J" Hard Jaw	"AL" Alum Jaw	"AL-2.5" High Alum Jaw	"C" Cast Jaw	Fixture Plate
CTHDM644	355	463	403	431	511	411
CTHDM645	405	513	453	481	561	461
CTHDM646	528	636	576	604	684	584
CTHDHM644	355	483	423	451	531	431
CTHDHM645	405	533	473	501	581	481
CTHDHM646	528	656	596	624	704	604
CTHDL443	158	198	182	190	214	202
CTHDL444	204	244	228	236	260	248
CTHDL445	252	292	276	284	308	296
CTHDL644	355	463	403	431	511	411
CTHDL645	403	511	451	479	559	459
CTHDL646	525	633	573	601	681	581
CTHDHL644	375	483	423	451	531	431
CTHDHL645	423	531	471	499	579	479
CTHDHL646	545	653	593	621	701	601

HD/HDL Vises and Towers

How To Order, Special Options, Fewer Components

HDLM6J [Manual 6" vise with hard jaws.]

HDHLM6AL2.5 [Hydraulic vise with optional height aluminum jaws.]

HDM6AL [Manual 6" vise with standard aluminum jaws.]

HDHM6AL2.5 [Hydraulic vise with optional height aluminum jaws.]



Fixture Plate (HD6ALP620-239) For HD Short Body

HDL Double Station Vise Examples:

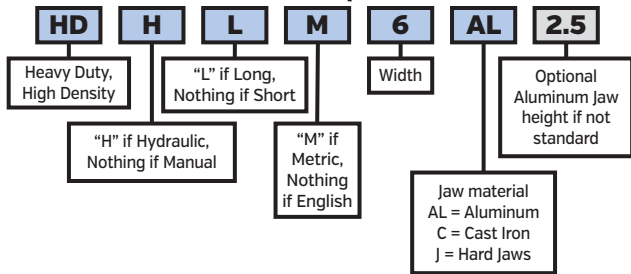

HD Double Station Vise Examples:

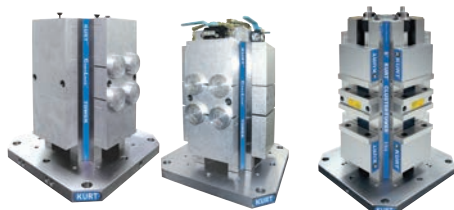
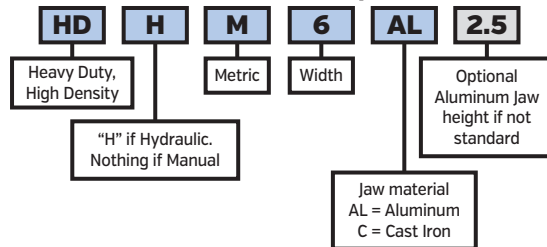

HD and HDL Cluster Tower Examples:

CTHDM643AL [Manual 6" short tower with 4 sides, 300mm base with standard height aluminum jaws.]

CTHDHM645AL2.5 [Hydraulic 6" tower with 4 sides, 500mm base with optional height aluminum jaws.]

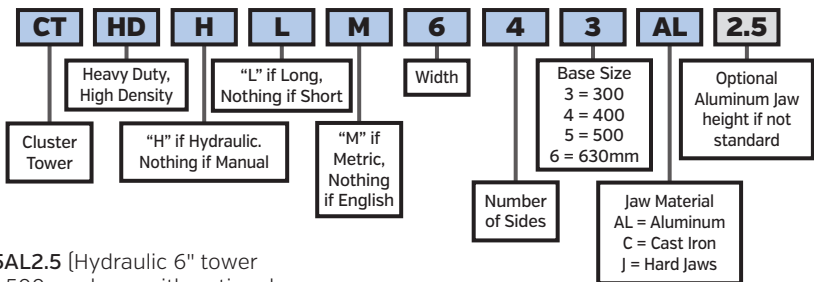

HD Back-To-Back Vises Examples:

THDM63AL [Manual 6" short back-to-back vise, 300mm base with standard height aluminum jaws.]

THDHM66AL2.5 [Hydraulic 6" short back-to-back vise, 630mm base with optional height aluminum jaws.]

Estimated weight: 88.9 Kgs/196 Lbs

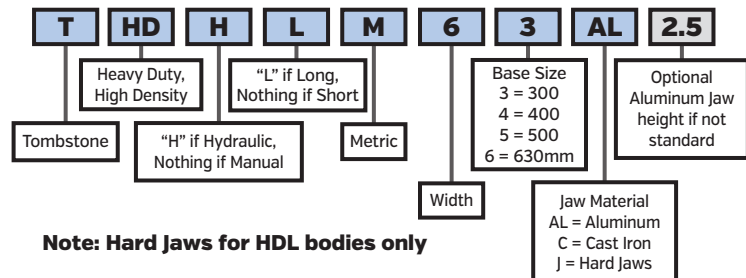
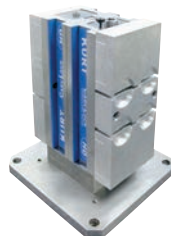

Note: Hard Jaws for HDL bodies only

HD & HDL Jaw Kits & Fixture Plates See Pages 44-47

ClusterLock Cluster Tower®

Model: CT2DC4B

Features:

- Made from ductile iron and steel, a stiffness of 2.5 times aluminum is achieved. Vibration damping of ductile iron is 20 times higher than aluminum. Includes hardened bed and jaws.
- Four double vises with 50mm [1.968"] wide jaw and 50mm [2"] opening.
- Pilot [0.8768"] in both ends. Four and six bolt mounting hole pattern fits all indexers. Has 60° center in outboard end.
- Convertible to single station large opening vise.
- Options include machinable jaws, tail support, workstops, and conversion kit.
- Chip guards included.
- 45 Lbs.

CT2DC4B Cluster Tower Double Manual Vise Clamping Force	
Torque-Ft. Lbs.	Lbs.
9	1,000
14	1,500
19	2,000
25	3,000
Maximum Force	3,000

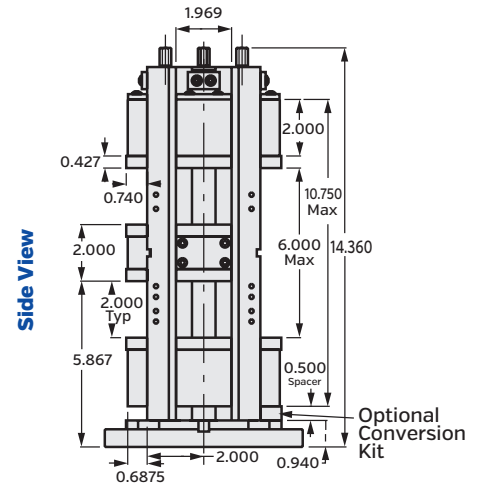
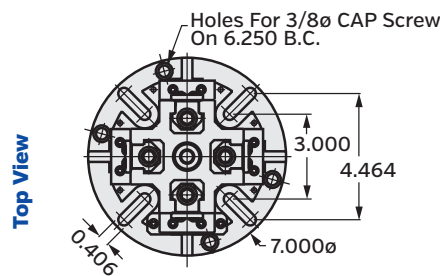

ClusterLock Cluster Tower®

Model: CT2SH4A

Features:

- Made from ductile iron and steel, a stiffness of 2.5 times aluminum is achieved. Vibration damping of ductile iron is 20 times higher than aluminum. Includes hardened bed and jaws.
- Four single vises with 50mm [1.968"] jaws and 50mm [2"] opening.
- Pilot [0.8768"] in both ends. Four and six bolt mounting hole pattern fits all indexers. Has 60° center in outboard end.
- Options include machinable jaws, tail support, workstops.
- Does not require tail support.
- Chip guards included.
- Internal hex screw standard.
- 25 Lbs.

CT2SH4A Cluster Tower Single Manual Vise Clamping Force	
Torque-Ft. Lbs.	Lbs.
10	1,000
15	1,500
20	2,000
25	3,000
Maximum Force	3,000

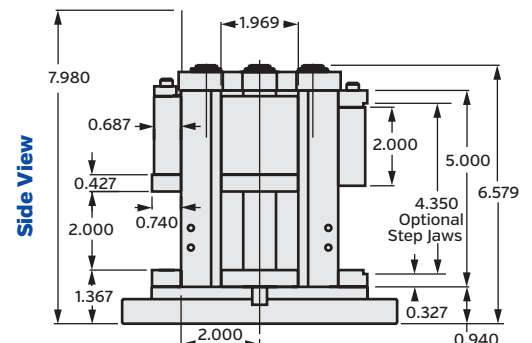
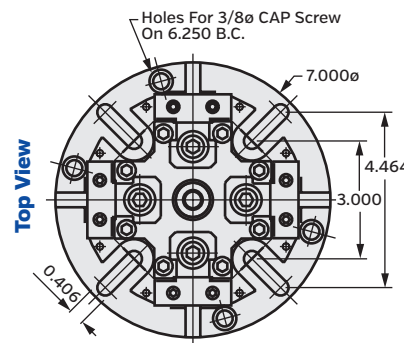
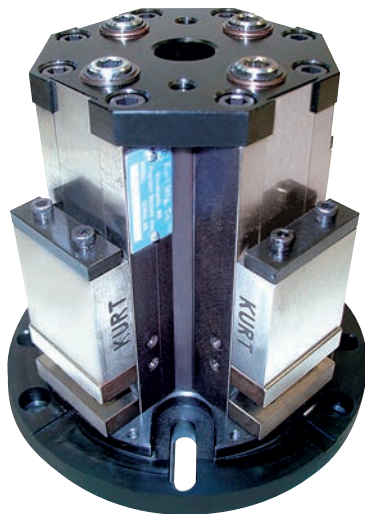



Modular ToolBlox™

2 Face Modular ToolBlox

Here's a new lighter weight building block module to add high density and versatility to most model horizontal machining centers. It is over 30% lighter than comparable size tombstones with aluminum sub-plates. Provides a lower cost alternative to dedicated fixtures. Features bolt holes and dowel pattern on each face for fast installation and removal of sub-plates and other workholding components. Class 30 Grey Iron.

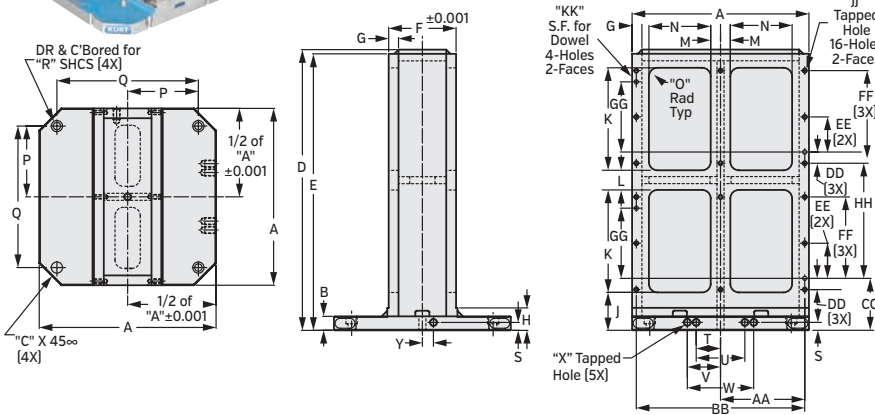

	2-Sided Tombstone Cage Dimensional Data		4-Sided Tombstone Cage Dimensional Data	
	TC2C40616	TC2C50820	TC4C40808	TC4C51010
A	400mm	500mm	400mm	500mm
B	1.250	1.250	1.250	1.250
C	1.970	2.360	1.970	2.360
D	25.000	28.000	25.000	28.000
E	24.625	27.625	24.625	27.625
F	6.000	8.000	8.000	10.000
G	0.875	0.875	0.875	0.875
H	2.000	2.000	2.000	2.000
J	3.375	3.375	3.375	3.375
K	9.125	10.500	9.500	10.625
L	1.750	2.000	1.000	1.750
M	0.875	1.000	2.500	3.375
N	5.500	7.125	5.000	6.750
O	0.750	0.750	0.750	0.750
P	6.299	7.874	6.299	7.874
Q	12.598	15.748	12.598	15.748
R	5/8	5/8	5/8	5/8
S	0.709	0.709	0.709	0.709
T	2.165	2.165	2.165	2.165
U	4.330	4.330	4.330	4.330
V	2.953	2.953	2.953	2.953
W	5.906	5.906	5.906	5.906
X	5/8-11NC x 1" DP	5/8-11NC x 1" DP	5/8-11NC x 1" DP	5/8-11NC x 1" DP
Y	0.984	0.984	0.984	0.984
AA	7.500	9.4375	3.625	4.625
BB	15.000	18.875	7.250	9.250
CC	4.625	4.625	5.125	5.125
DD	1.000	1.000	1.000	1.000
EE	4.125	4.625	4.125	4.625
FF	8.250	9.250	8.250	9.250
GG	6.250	7.250	1.500	1.500
HH	11.250	12.750	4.125	4.625
JJ	3/8-16NC x 0.88 DP	3/8-16NC x 0.88 DP	8.250	9.250
KK	0.3750 x 0.75 DP	0.3750 x 0.75 DP	5.750	6.750
LL	-	-	11.250	12.750
MM	-	-	3/8-16NC x 0.88 DP	3/8-16NC x 0.88 DP
NN	-	-	0.3750 x 0.75 DP	0.3750 x 0.75 DP
Est Weight	326 Lbs	546 Lbs	245 Lbs	361 Lbs
Est Weight	148 Kgs	248 Kgs	112 Kgs	164 Kgs



Modular ToolBlox™

4 Face Modular ToolBlox

This 4 sided tombstone is another lower cost option over dedicated fixtures. It is over 30% lighter than comparable size tombstones with aluminum sub-plates and is designed to reduce setup time. Provides versatility for mounting manual and hydraulic vises and most clamping devices. Standard and custom sub-plates are also available. Class 30 Grey Iron.

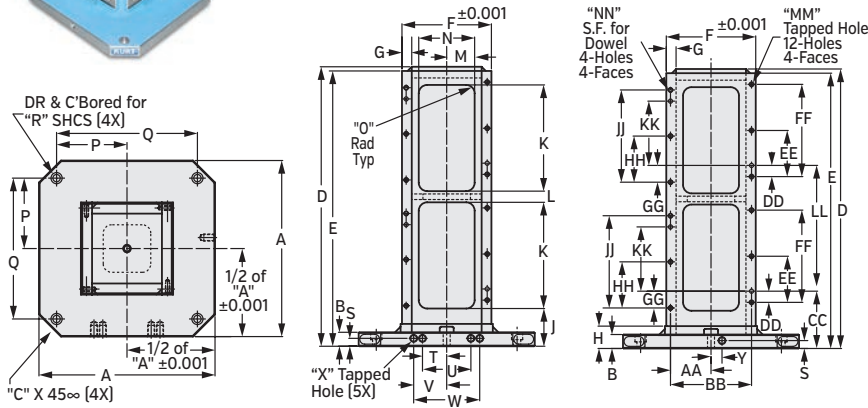

Fixture Plates

- Please specify material as A36 HRS, 7075 Aluminum or ATP-5 Aluminum Jig Plate
- Each plate is furnished with all necessary dowels & screws for mounting to ToolBlox
- Customized hole patterns & features can be supplied upon request
- Fixture plate thickness tolerances are: A36 = ±0.001, 7075 = ±0.001, ATP-5 = ±0.005
- Fixture plates are ground flat & parallel to: A36 = 0.001, 7075 = 0.001, ATP-5 = 0.005
- You can permanently mount Kurt vises to the ToolBlox fixture plates for fast, easy set-up changes on milling machines.

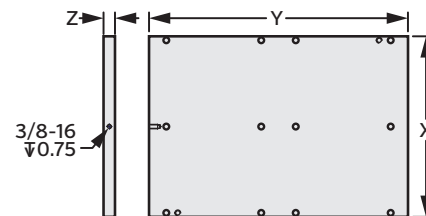

Model	TC2C40616	TC2C50820	TC4C0808	TC4C51010
Part #	FP416	FP520	FP408	FP510
X	15.688	19.625	8.000	10.000
Y	22.500	25.500	22.250	25.500
Z	1.000	1.000	1.000	1.000

Note: Outside dimensions [X&Y] are cut dimensions

ToolBlox™ 2 Face ToolBlox



The Kurt 2 face ToolBlox is ideal for mounting vises. Sub-plates may be bolted and doweled on either side for quick, easy set-up. All vises or collet chucks may be mounted directly on Kurt ToolBlox faces. Made of Class-35 cast iron. Consult our factory for other sizes.

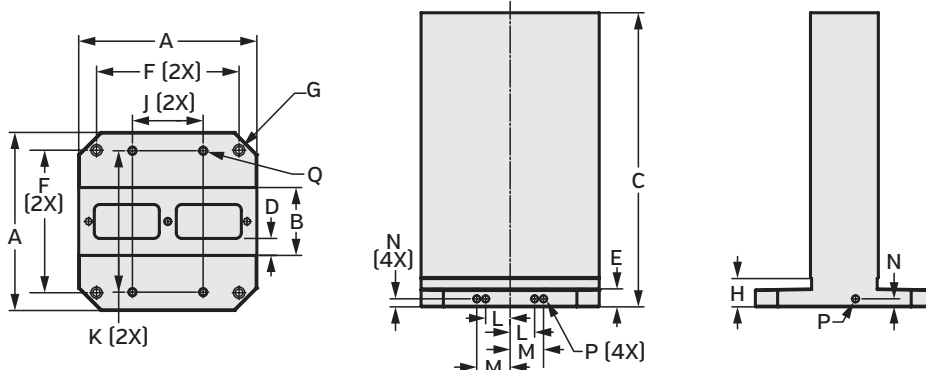

Model	A	B	C	D	E	F	G [SHCS]	H	J	K	L	M	N	P	Q [SHCS]	Est. Wt Kgs/Lbs.	Surface Datum A Base Flatness	Face Perp. To Base	Edge Locator Perp	Face Dimension	Face Locator to Edge Parallelism
TB2C40616	400 mm	6.00	26.00	1.50	1.50	320 mm	5/8" or M16	2.50	6.25	12.50	55 mm	75 mm	18 mm	5/8-11UNC	1/2" or 13 mm	235 / 516	0.001	0.003	0.0015	6,000 ±0.002	0.001
TB2C50820	500 mm	8.00	34.00	1.50	1.75	400 mm	5/8" or M16	2.75	8.00	16.00	55 mm	75 mm	18 mm	5/8-11UNC	1/2" or 13 mm	412 / 908	0.001	0.003	0.0015	8,000 ±0.002	0.001
TB2C60825	630 mm	8.00	38.00	2.00	2.00	500 mm	5/8" or M16	3.00	10.00	20.00	-	100 mm	18 mm	5/8-11UNC	1/2" or 13 mm	663 / 1461	0.001	0.003	0.0015	8,000 ±0.002	0.001

Note: ToolBlox can be cut down to any height.

ToolBlox™ 4 Face ToolBlox



The Kurt 4 face ToolBlox is ideal for mounting vises of any size. Made of Class-35 cast iron. Consult our factory for other available sizes.

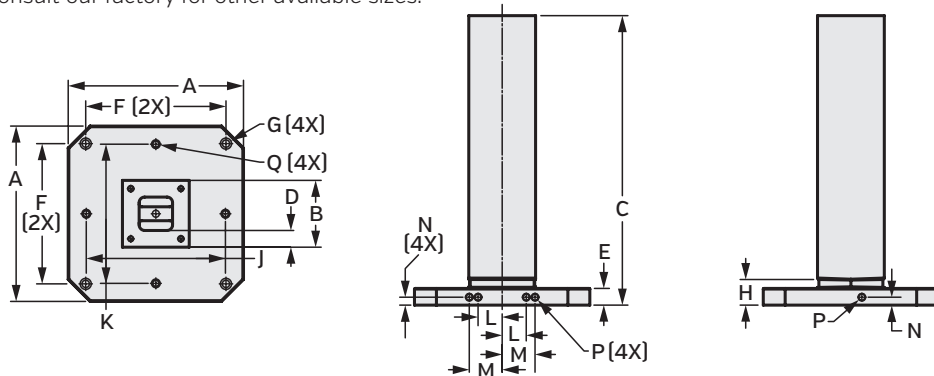

Model	A	B	C	D	E	F	G [SHCS]	H	J	K	L	M	N	P	Q [SHCS]	Est. Wt Kgs/Lbs.	Surface Datum A Base Flatness	Face Perp. To Base	Edge Locator Perp	Face Dimension	Face Locator to Edge Parallelism
TB4C40606	400 mm	6.00	26.00	1.50	1.50	320 mm	5/8" or M16	2.50	12.50	12.50	55 mm	75 mm	18 mm	5/8-11UNC	1/2" or 13 mm	128 / 282	0.001	0.003	0.0015	6,000 ±0.002	0.002
TB4C40808	400 mm	8.00	26.00	1.50	1.50	320 mm	5/8" or M16	2.50	12.50	12.50	55 mm	75 mm	18 mm	5/8-11UNC	1/2" or 13 mm	163 / 359	0.001	0.003	0.0015	8,000 ±0.003	0.002
TB4C41010	400 mm	10.00	26.00	1.50	1.50	320 mm	5/8" or M16	2.50	12.50	12.50	55 mm	75 mm	18 mm	5/8-11UNC	1/2" or 13 mm	198 / 436	0.001	0.003	0.0015	10,000 ±0.004	0.002
TB4C50808	500 mm	8.00	34.00	1.50	1.75	400 mm	5/8" or M16	2.90	16.00	16.00	55 mm	75 mm	18 mm	5/8-11UNC	1/2" or 13 mm	237 / 522	0.001	0.003	0.0015	8,000 ±0.004	0.002
TB4C51010	500 mm	10.00	34.00	1.50	1.75	400 mm	5/8" or M16	2.90	16.00	16.00	55 mm	75 mm	18 mm	5/8-11UNC	1/2" or 13 mm	284 / 626	0.001	0.003	0.0015	10,000 ±0.005	0.002
TB4C51212	500 mm	12.00	34.00	1.50	1.75	400 mm	5/8" or M16	2.90	16.00	16.00	55 mm	75 mm	18 mm	5/8-11UNC	1/2" or 13 mm	333 / 734	0.001	0.003	0.0015	12,000 ±0.007	0.002
TB4C51414	500 mm	14.00	34.00	1.50	1.75	400 mm	5/8" or M16	2.90	16.00	16.00	55 mm	75 mm	18 mm	5/8-11UNC	1/2" or 13 mm	440 / 970	0.001	0.003	0.0015	14,000 ±0.008	0.002
TB4C61010	630 mm	10.00	38.00	1.50	1.75	500 mm	5/8" or M16	3.20	20.00	20.00	-	100.00	18 mm	5/8-11UNC	1/2" or 13 mm	369 / 812	0.001	0.003	0.0015	10,000 ±0.009	0.002
TB4C61818	630 mm	18.00	38.00	2.00	2.00	500 mm	5/8" or M16	3.20	20.00	20.00	-	100.00	18 mm	5/8-11UNC	1/2" or 13 mm	778 / 1715	0.001	0.003	0.0015	18,000 ±0.010	0.002

Note: ToolBlox can be cut down to any height.

SideWinder™

Model: SDW35

The Kurt SDW35 SideWinder is a vise that mounts vertically to the back of any Kurt industry standard 6 or 8" vise. The SideWinder includes a stabilization leg that will mount to the table on the movable end of the vise and a workstop to position the height of the part.

Purpose:

For doing 2nd op work holding the part vertically rather than horizontally.

Advantages:

- Saves set up time for 2nd op vertical work
- Machining can be done on both vises in the same setup
- Vise is at an elevated position which is more conducive to longer reach machining
- Has a stabilizer foot for vibration control
- Can be mounted to the back of any Kurt industry standard 6" or 8" vises. (Included spacer required when mounting to a 3800 series vise)
- Does not interfere with the host vise
- Pull type vise
- AngLock design
- Patented

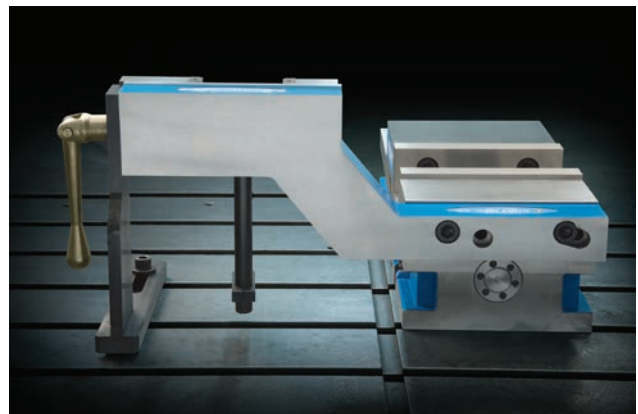

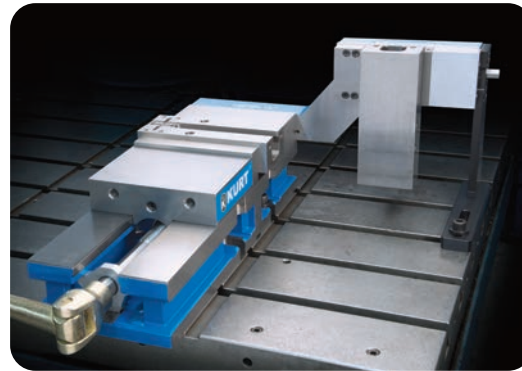
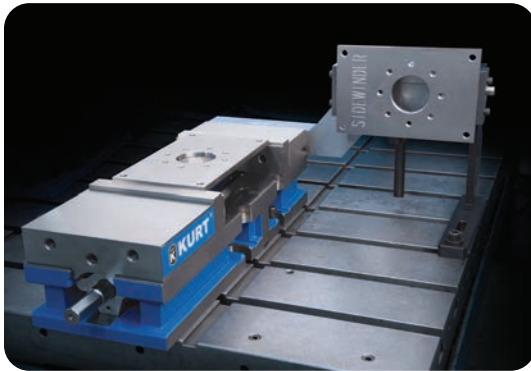
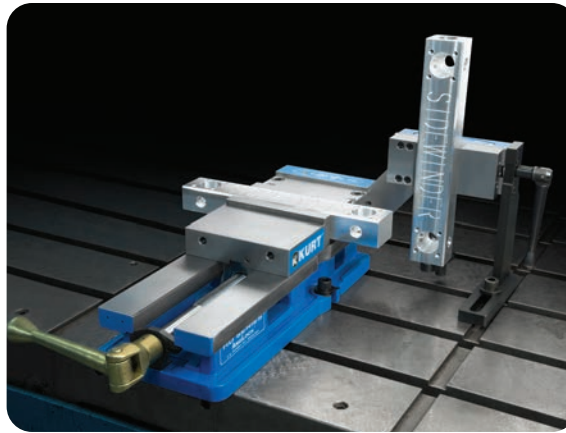
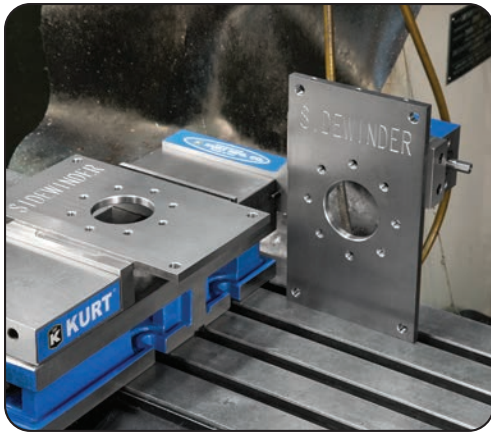

SideWinder Dimensions

SDW35

A	20.86
B	9.80/10.70
C	19.81
D	1.235
E	3.47
F	3.56
G	2.38
H	0.0/3.75
J	0.25/4.00
K	3.875
L	6.000
M	4.750
N	8.00
P	7.17
Q	2.000
R	2.30
S	0.80
T	9/16
U	1/2-13
V	5/8-11
W	5.75
Weight	45 Lbs.

Clamp Force

SDW35 SideWinder

Torque-Ft. Lbs.	Clamping Force-Lbs.
5	500
10	1,000
15	1,500
20	2,000
25	2,500
30	3,000
35	3,500
40	4,000

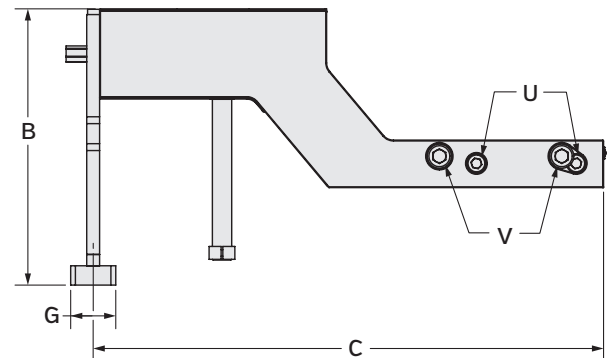
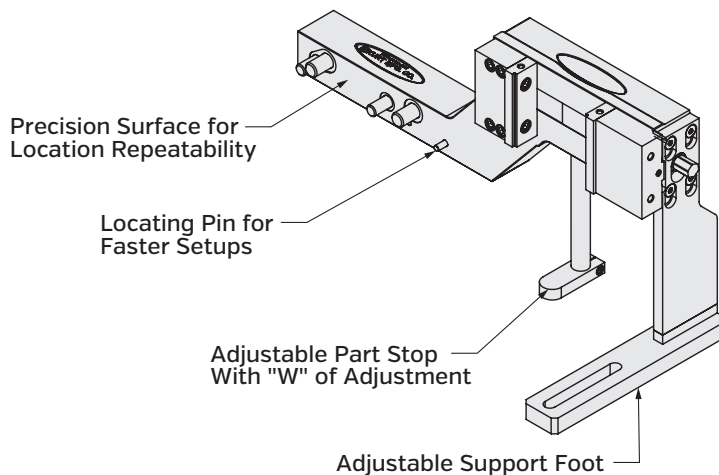
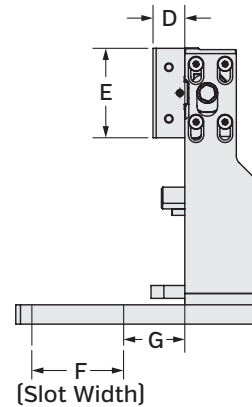
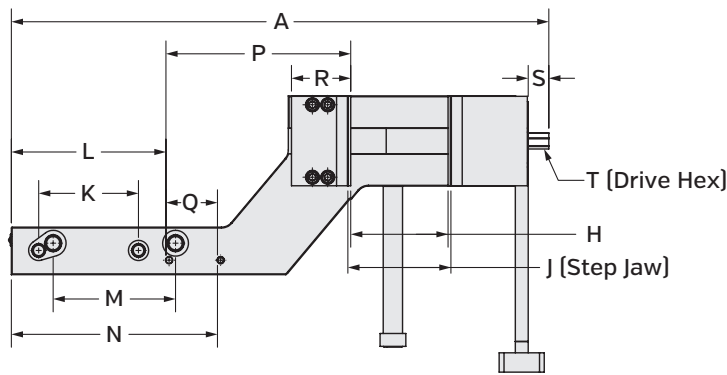

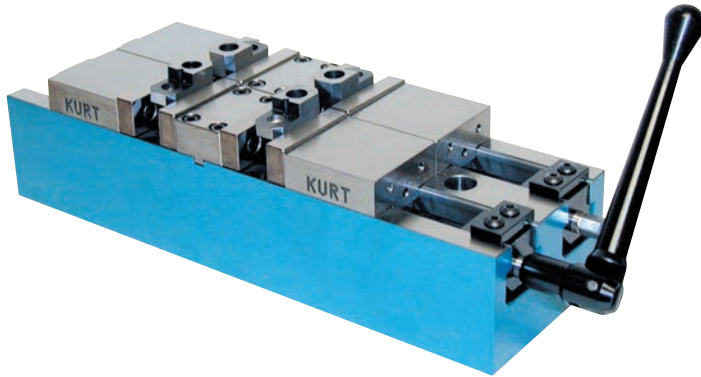

ClusterLock

Model: CL2D2-2A

ClusterLock is a precision double vise, configured from 1 to 10 units in a common base. The AngLock principle ensures that the movable jaw will not lift.

Features:

- 80,000-PSI ductile iron construction.
- Hardened bed ways and hardened steel jaw plates.
- Standard spacing is 1.968" (50mm). Consult the factory for other spacing.
- Vise bed surface is ground parallel to within 0.001".
- Ideal for small VMC's with pallet changers.
- Suitable for tombstone mounting on HMC's.
- Can be converted to single opening [6" maximum] with the optional convertible kit.

Part #	Weight Lbs.	ClusterLock Manual Vise Clamping Vise	
		Torque- Ft. Lbs.	Lbs.
CL2D1-2A	12	9	1,000
CL2D2-2A	24	14	1,500
CL2D4-2A	48	19	2,000
CL2D6-2A	72	25	3,000
CL2D8-2A	96		
CL2D10-2A	120		

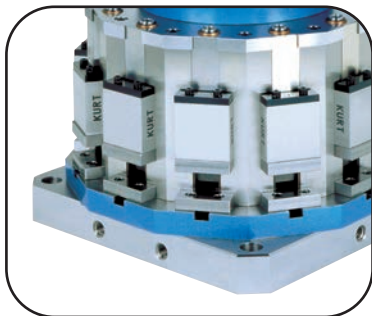

Top View

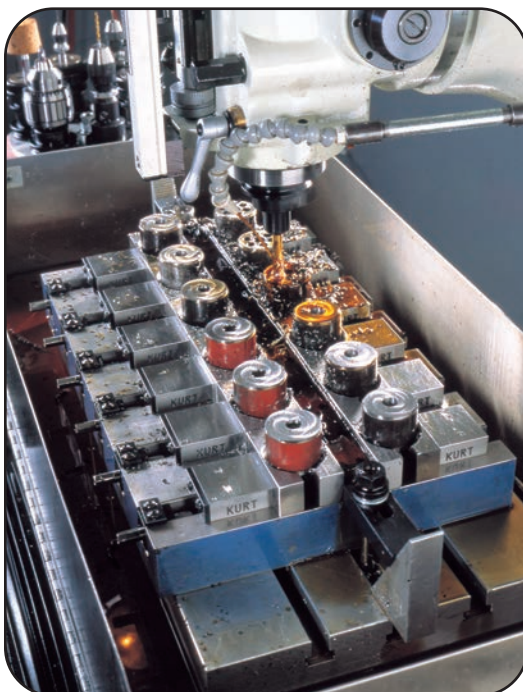
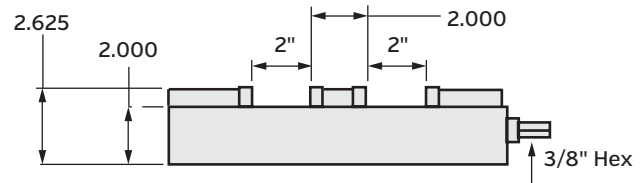

Side View

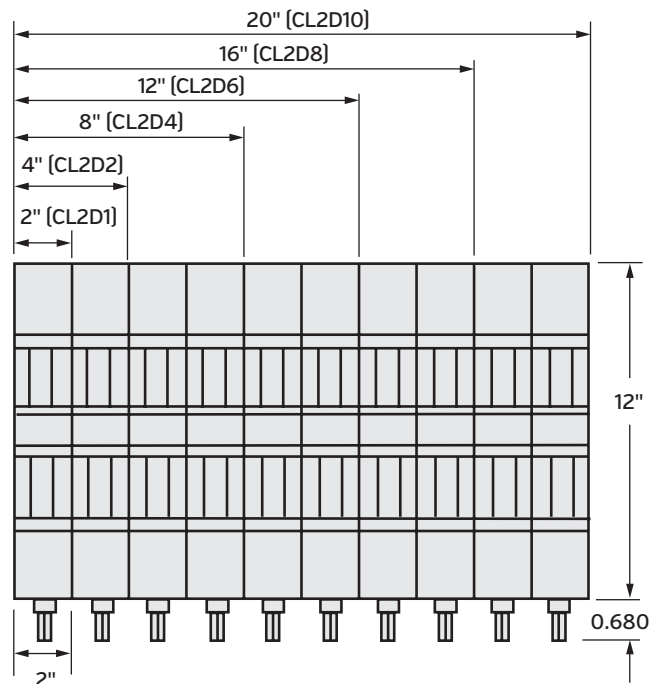

Kurt Toolroom Vise

Model: KTR35

An extremely versatile vise that can fit on the smallest machine tables with ease. The overall length including hex is 10.125" and weighs only 20 pounds. The jaw is 3.470" wide with a maximum opening of 3.81" on the bed, and 4.06" in step of jaw. The vise is fully chip guarded. Mounting can be accomplished through the body or with outrigger toe clamps mounted to the outside of the body (sold separately). All sides of the vise are ground and can easily be mounted on its side with the toe clamps (sold separately). Four cavities in the ends of the body make mounting this vise with the toe clamps very quick and easy. By using a receiver vise this vise can be used as a sine vise with 30, 45 and 60° angles built into the side of the body on the stationary side. To utilize this feature remove the triangular shaped magnets and place the dowel pins in the proper holes to get the angle you desire.

Features:

- Jaw Width: 3.470"
- Jaw Height Overall: 1.235"
- Jaw Height to Step: 1.118"
- Max Clamping Force: 4,500 Lbs.
- Hex Size: 0.561"
- Overall Vise Length: 10.125"
- Base Height: 2.000"

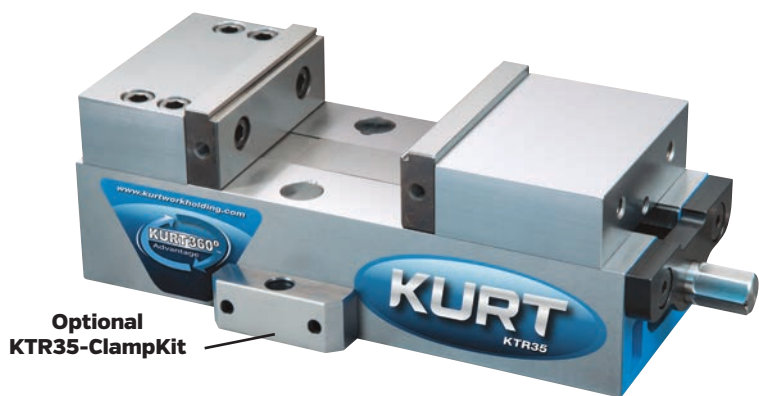

Optional KTR35-ClampKit

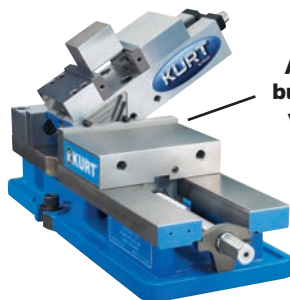

Angles are built into the vise body.



Mounts on side with optional KTR35-ToeKit



Optional KTR35-ToeKit



Optional KTR35-ClampKit (3/8")
Optional KTR3512-ClampKit (1/2")



Optional KTR35-KeyKit

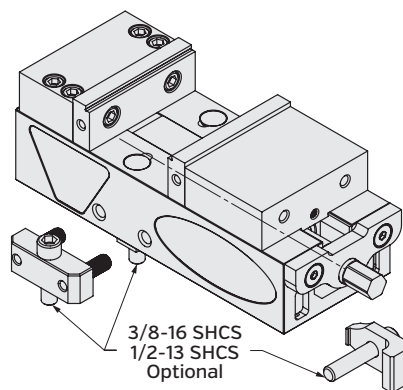

3/8-16 SHCS
1/2-13 SHCS
Optional

KTR35 Clamp Force	
Torque-Ft. Lbs.	Clamping Force-Lbs.
5	500
10	1,000
15	1,500
20	2,000
25	2,500
30	3,000
35	3,500
40	4,000
45	4,500
Weight	20 Lbs.

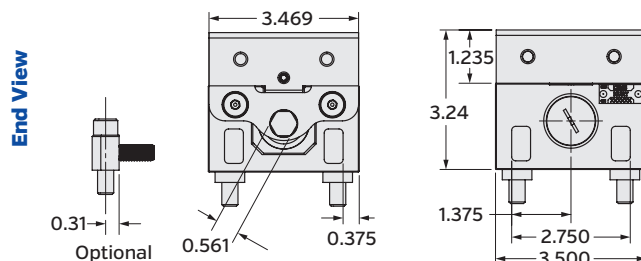
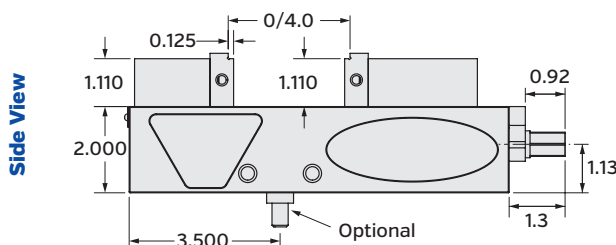
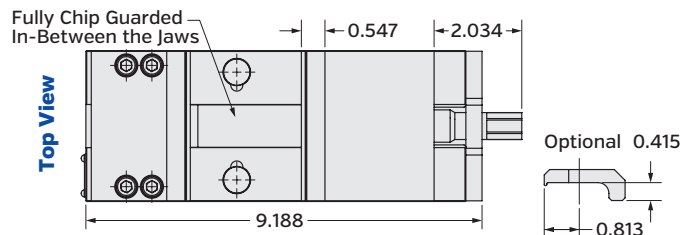
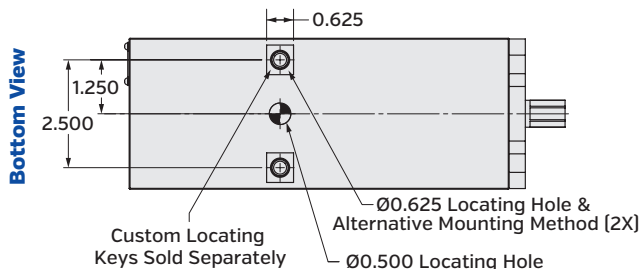

Self-Centering Vise

Models: SCD430 | SCD640

Kurt has two Self-Centering vises, a 4" jaw width [SCD430] and a 6" jaw width [SCD640]. Jaw opening on the 4" model is 6.25" and 8" on the 6". Centering accuracy from minimum to maximum opening is 0.0006" with 0.0002" repeatability. Both movable jaws are AngLock design with zero lift. A unique feature is an adjustment that allows the centerline of the jaws to be set. This is especially important when mounting several vises on one machine and all centerlines must match.

Features:

- Lip seals on main screw.
- Chip guards.
- Hardened jaws.
- Hardened bed ways.
- 80,000-PSI ductile iron construction.



Top View

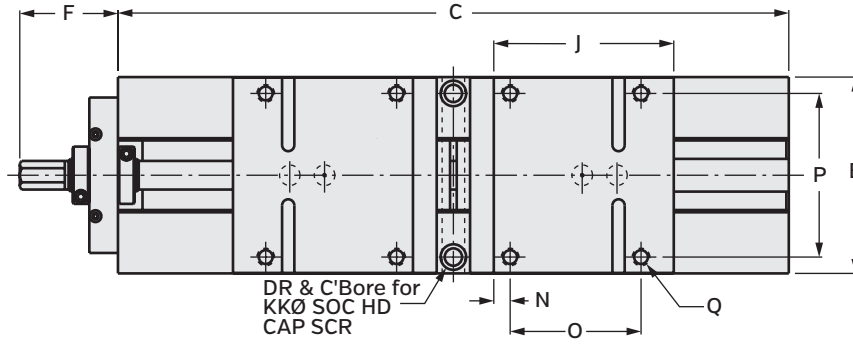

Side View

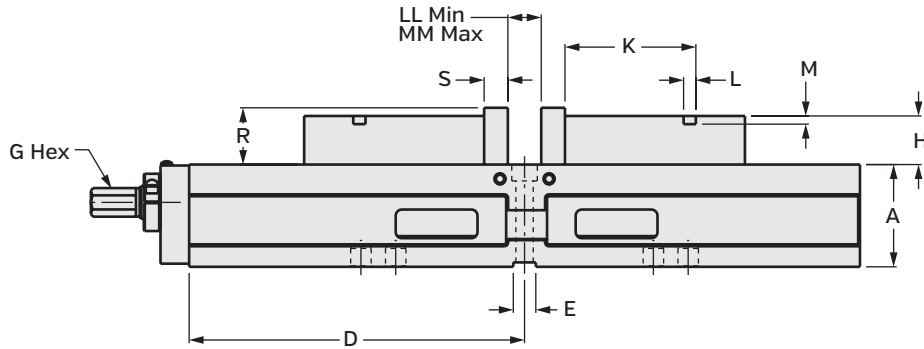

Bottom View
(Mounting hole pattern)

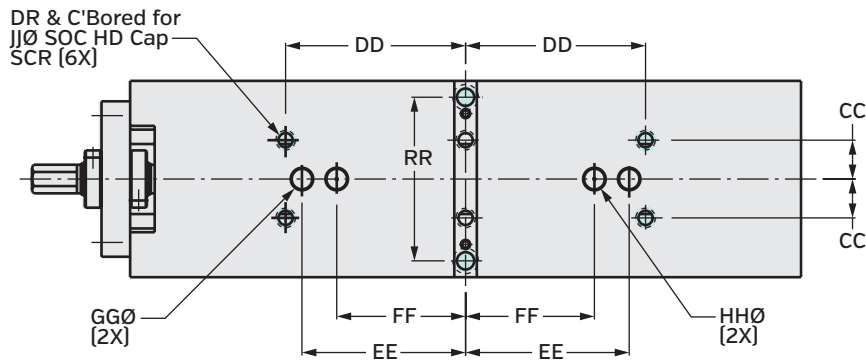

Front View

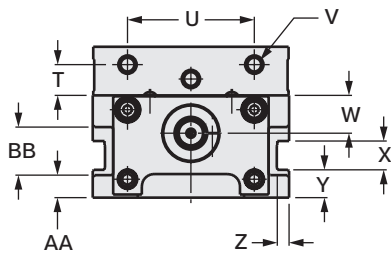

Jaw Position

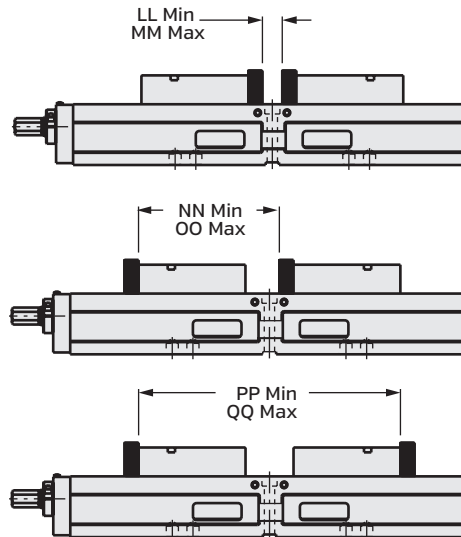

VISE CLAMPING FORCE-LBS.		
Torque-Ft. Lbs.	SCD430	SCD640
10	500	985
20	1,100	1,760
30	1,800	2,576
40	2,500	3,770
50	3,300	4,382
60	4,100	5,764

Dimensional Data		
	SCD430	SCD640
A	2.375	3.125
B	4.000	6.000
C	15.500	20.500
D	7.750	10.250
E	0.5005	0.6880
F	2.400	3.000
G	9/16	3/4
H	1.115	1.485
J	4.000	5.500
K	3.000	4.000
L	0.250	0.375
M	0.188	0.250
N	0.312	0.500
O	3.000	4.000
P	3.312	5.000
Q	5/16-18	1/2-13
R	1.235	1.735
S	0.547	0.725
T	0.687	0.940
U	2.500	3.875
V	3/8-16	1/2-13
W	0.871	1.156
X	0.690	0.880
Y	0.700	0.850
Z	0.250	0.360
AA	0.550	0.690
BB	1.000	1.470
CC	0.813	1.188
DD	3.750	5.500
EE	5.000	5.000
FF	3.370	3.937
GG	0.625	0.625
HH	0.630	0.630
JJ	5/16	3/8
KK	3/8	1/2
LL	1.000	1.000
MM	6.250	8.000
NN	5.540	7.240
OO	10.790	14.240
PP	10.090	13.470
QQ	15.340	20.470
RR	3.000	5.000
Est. Weight	40 Lbs	100 Lbs

Extra Capacity 6" XL Vises

Models: XL6 | XL6R | XL6H | XL6HR | XL6A | XL6AR

Kurt XL vises are designed for precision clamping of very large parts for both tool and die and production CNC applications. With up to a 28.750" jaw opening, these vises lock precisely, even for high horsepower "hogging out" operations. All sides of Kurt XL vises are accurate to within 0.001" for precise, easy alignment in multiples. XL vises may be mounted and used as receivers for other workholding devices.

Features:

- AngLock design reduces jaw lift.
- 80,000-PSI ductile iron body.
- "Pull-Type" clamping means high precision and repeatability.
- Great for high horsepower "hogging out" applications.
- Reverse model reduces "reach-over" distance making part loading safer and easier for the operator. Also part programming is easier in the "Y" axis positive direction.
- Manual, air and hydraulic models available.
- Air and hydraulic feature a 1/4" stroke.
- Air power option provides a precise and repeatable "gentle touch" for delicate parts.
- Internal hex screw available.



XL6 Manual Version



XL6R Manual Reverse Version

XL6H and XL6HR

- New hydraulic model is capable of: Single acting with spring return for unclamp, or Double acting with hydraulic unclamp. Includes fittings for both configurations.
- Threaded ports on body: Female 1/8" NPT
- Included adapters: Male 1/8" NPT to Male #4 JIC, quantity of two

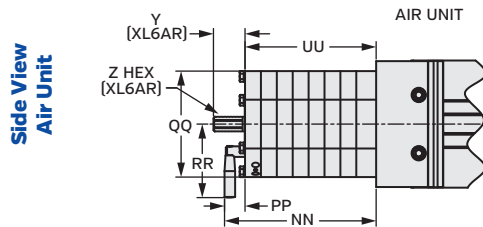

Side View
Air Unit

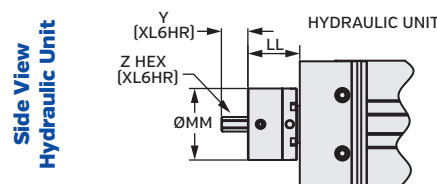

Side View
Hydraulic Unit

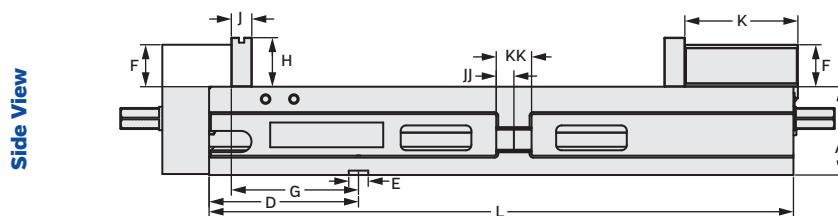

Side View

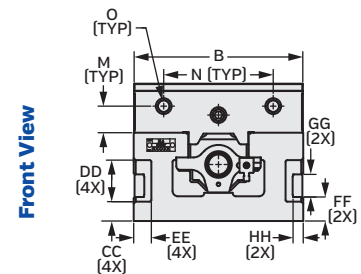

Front View

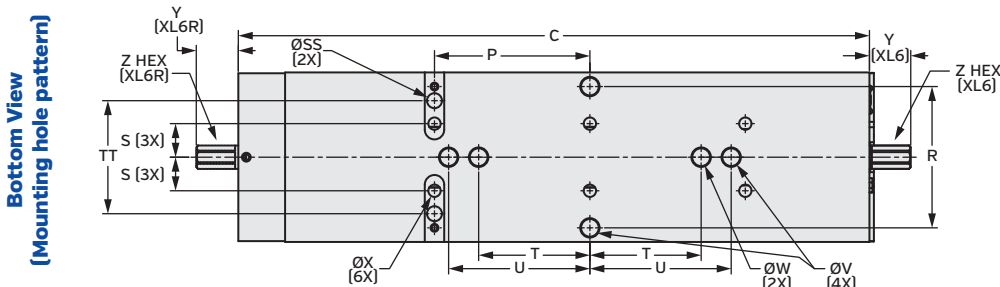

Bottom View
(Mounting hole pattern)

Vise Mounting Options - See page 80

	Dimensional Data					
	Standard	Reverse	Hydraulic	Hydraulic Reverse	Air	Air Reverse
	XL6	XL6R	XL6H	XL6HR	XL6A	XL6AR
A	3.125	3.125	3.125	3.125	3.125	3.125
B	6.000	6.000	6.000	6.000	6.000	6.000
C	22.40	22.40	22.40	22.40	22.40	22.40
D	5.287	5.287	5.287	5.287	5.287	5.287
E	0.688	0.688	0.688	0.688	0.688	0.688
F	1.485	1.485	1.485	1.485	1.485	1.485
G	4.500	4.500	4.500	4.500	4.500	4.500
H	1.735	1.735	1.735	1.735	1.735	1.735
J	0.725	0.725	0.725	0.725	0.725	0.725
K	4.00	4.00	4.00	4.00	4.00	4.00
L	20.68	20.68	20.68	20.68	20.68	20.68
M	0.94	0.94	0.94	0.94	0.94	0.94
N	3.875	3.875	3.875	3.875	3.875	3.875
O	1/2-13	1/2-13	1/2-13	1/2-13	1/2-13	1/2-13
P	5.500	5.500	5.500	5.500	5.500	5.500
R	5.000	5.000	5.000	5.000	5.000	5.000
S	1.188	1.188	1.188	1.188	1.188	1.188
T	100 MM	100 MM	100 MM	100 MM	100 MM	100 MM
U	5.000	5.000	5.000	5.000	5.000	5.000
V	0.625	0.625	0.625	0.625	0.625	0.625
W	16 MM	16 MM	16 MM	16 MM	16 MM	16 MM
X	0.438	0.438	0.438	0.438	0.438	0.438
Y	1.500	1.500	1.500	1.500	1.500	1.500
Z	0.750	0.750	0.750	0.625	0.750	0.625
AA	14.50	14.50	14.50	14.50	14.50	14.50
BB	19.25	19.25	19.25	19.25	19.25	19.25
CC	0.69	0.69	0.69	0.69	0.69	0.69
DD	1.47	1.47	1.47	1.47	1.47	1.47
EE	0.63	0.63	0.63	0.63	0.63	0.63
FF	0.85	0.85	0.85	0.85	0.85	0.85
GG	0.80	0.80	0.80	0.80	0.80	0.80
HH	0.375	0.375	0.375	0.375	0.375	0.375
JJ	0.63	0.63	0.63	0.63	0.63	0.63
KK	1.25	1.25	1.25	1.25	1.25	1.25
LL	-	-	2.500	2.500	-	-
MM	-	-	3.38	3.38	-	-
NN	-	-	-	-	7.20	7.20
PP	-	-	-	-	1.00	1.00
QQ	-	-	-	-	5.00	5.00
RR	-	-	-	-	3.50	3.50
SS	0.531	0.531	0.531	0.531	0.531	0.531
TT	4.000	4.000	4.000	4.000	4.000	4.000
UU	-	-	-	-	6.187	6.187
Weight	100 Lbs	100 Lbs	105 Lbs	105 Lbs	106 Lbs	106 Lbs
Hydraulic Displacement Cu. In.	-	-	0.69	0.69	-	-

Vise Clamping Force-Lbs.		
Manual Torque Ft.-Lbs.	Manual	
	XL6	XL6R
10	786	786
20	1,800	1,800
30	2,508	2,508
40	3,423	3,423
50	4,210	4,210
60	5,020	5,020
70	6,287	6,287
80	6,884	6,884

Vise Clamping Force-Lbs.		
Hydraulic PSI	Hydraulic	
	XL6H	XL6HR
400	900	900
800	1,525	1,525
1,200	2,750	2,750
1,600	3,650	3,650
2,000	4,600	4,600
2,400	5,500	5,500
2,800	6,425	6,425
3,200	7,350	7,350

Note: Clamping force is only estimated

Vise Clamping Force-Lbs.		
Air PSI	Air	
	XL6A	XL6AR
10	320	320
20	840	840
30	1,280	1,280
40	1,780	1,780
50	2,200	2,200
60	2,720	2,720
70	3,240	3,240
80	3,800	3,800
90	4,380	4,380
100	5,000	5,000

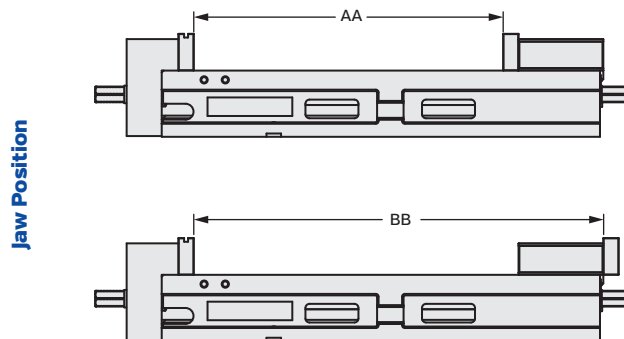



8XLPTLSS Manual Version

Extra Capacity 8" XL Vises

Kurt XL vises are designed for precision clamping of very large parts for both tool and die and production CNC applications. With up to a 28.750" jaw opening, these vises lock precisely, even for high horsepower "hogging out" operations. All sides of Kurt XL vises are accurate to within 0.001" for precise, easy alignment in multiples. XL vises may be mounted and used as receivers for other workholding devices.

Features:

- AngLock design reduces jaw lift.
- 80,000-PSI ductile iron body.
- "Pull-Type" clamping means high precision and repeatability.
- Great for high horsepower "hogging out" applications.
- Reverse model reduces "reach-over" distance making part loading safer and easier for the operator. Also part programming is easier in the "Y" axis positive direction.
- Manual, air and hydraulic models available.
- Air and hydraulic feature a 1/4" stroke.
- Air power option provides a precise and repeatable "gentle touch" for delicate parts.
- Internal hex screw available.

8XLPTLSHS and 8XLPTLSHR

- New hydraulic model is capable of: Single acting with spring return for unclamp, or Double acting with hydraulic unclamp. Includes fittings for both configurations.
- Threaded ports on body: Female 1/8" NPT
- Included adapters: Male 1/8" NPT to Male #4 JIC, quantity of two

Standard (S)

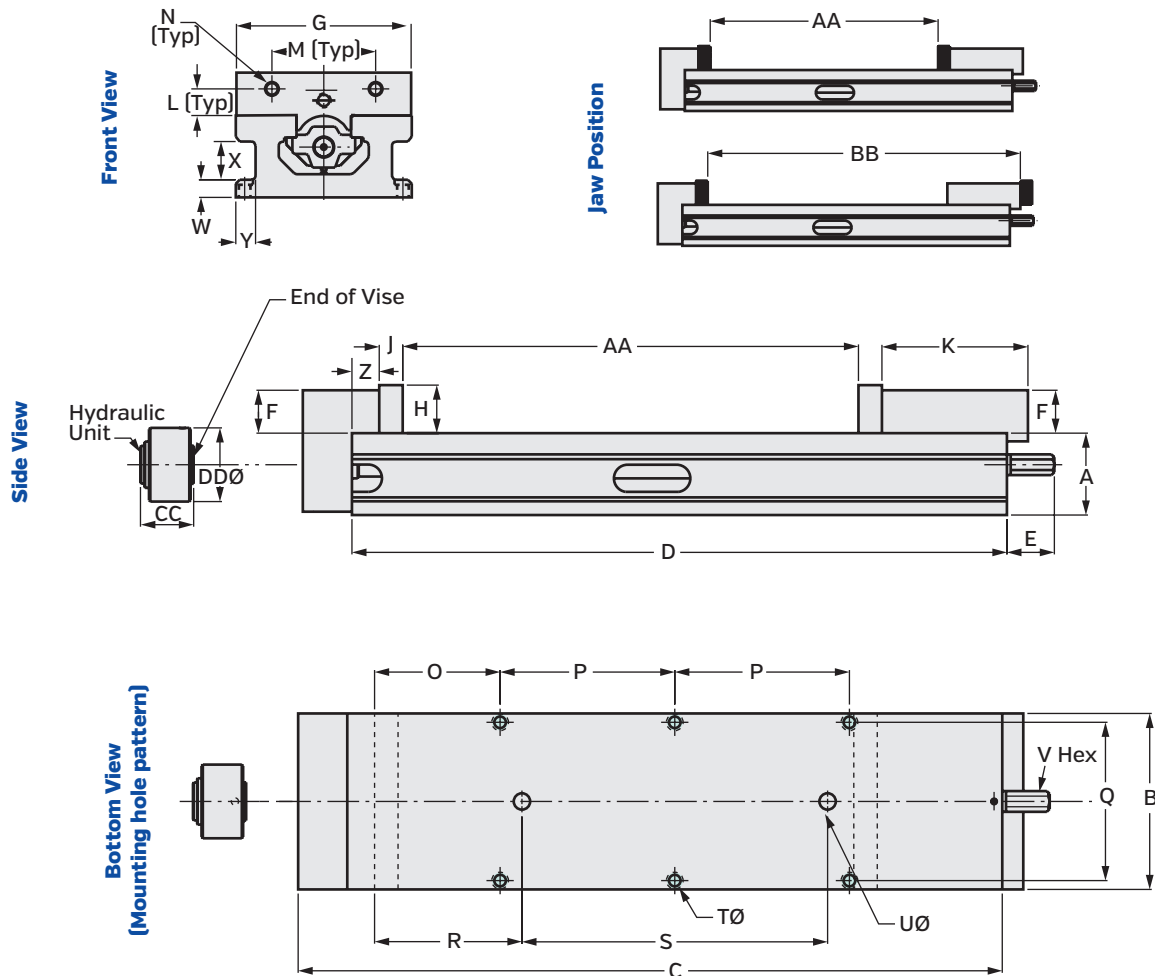

Vise Clamping Force-Lbs.		
Hydraulic PSI	Hydraulic	
	8XLPTLSHS	8XLPTLSHR
400	900	900
800	1,525	1,525
1,200	2,750	2,750
1,600	3,650	3,650
2,000	4,600	4,600
2,400	5,500	5,500
2,800	6,425	6,425
3,200	7,350	7,350

Note: Clamping force is only estimated

Vise Clamping Force-Lbs.		
Manual Torque Ft.-Lbs.	Manual	
	8XLPTLSS	8XLPTLSR
20	2,904	2,904
40	5,664	5,664
60	7,872	7,872
80	10,824	10,824
100	13,848	13,848
120	16,632	16,632
140	19,008	19,008
160	20,376	20,376

	Dimensional Data			
	Manual		Hydraulic	
	8XLPTLSS	8XLPTLSR	8XLPTLSHS	8XLPTLSHR
A	3.750	3.750	3.750	3.750
B	8.060	8.060	8.060	8.060
C	32.250	32.250	32.250	32.250
D	30.000	30.000	30.000	30.000
E	2.170	1.890	2.160	-
F	1.965	1.965	1.965	1.965
G	8.000	8.000	8.000	8.000
H	2.200	2.200	2.200	2.200
J	1.075	1.075	1.075	1.075
K	6.690	6.690	6.690	6.690
L	1.220	1.220	1.220	1.220
M	4.750	4.750	4.750	4.750
N	5/8-11	5/8-11	5/8-11	5/8-11
O	5.750	5.750	5.750	5.750
P	8.000	8.000	8.000	8.000
Q	7.250	7.250	7.250	7.250
R	6.750	6.750	6.750	6.750
S	14.000	14.000	14.000	14.000
T	1/2	1/2	1/2	1/2
U	0.750	0.750	0.750	0.750
V	7/8	3/4	7/8	-
W	0.810	0.810	0.810	0.810
X	1.750	1.750	1.750	1.750
Y	0.900	0.900	0.900	0.900
Z	1.250	1.250	1.250	1.250
AA	21.000	21.000	21.000	21.000
BB	28.765	28.765	28.765	28.765
CC	-	-	2.500	2.500
DD	-	-	3.375	3.375
EE	-	-	-	1.940
FF	-	-	-	5/8
Weight	230 Lbs	235 Lbs	230 Lbs	235 Lbs
Hydraulic Displacement Cu. In.	-	-	0.69	0.69

Note: Keyway slots can be machined in. Call CEW group for quotation 1-877-226-7823

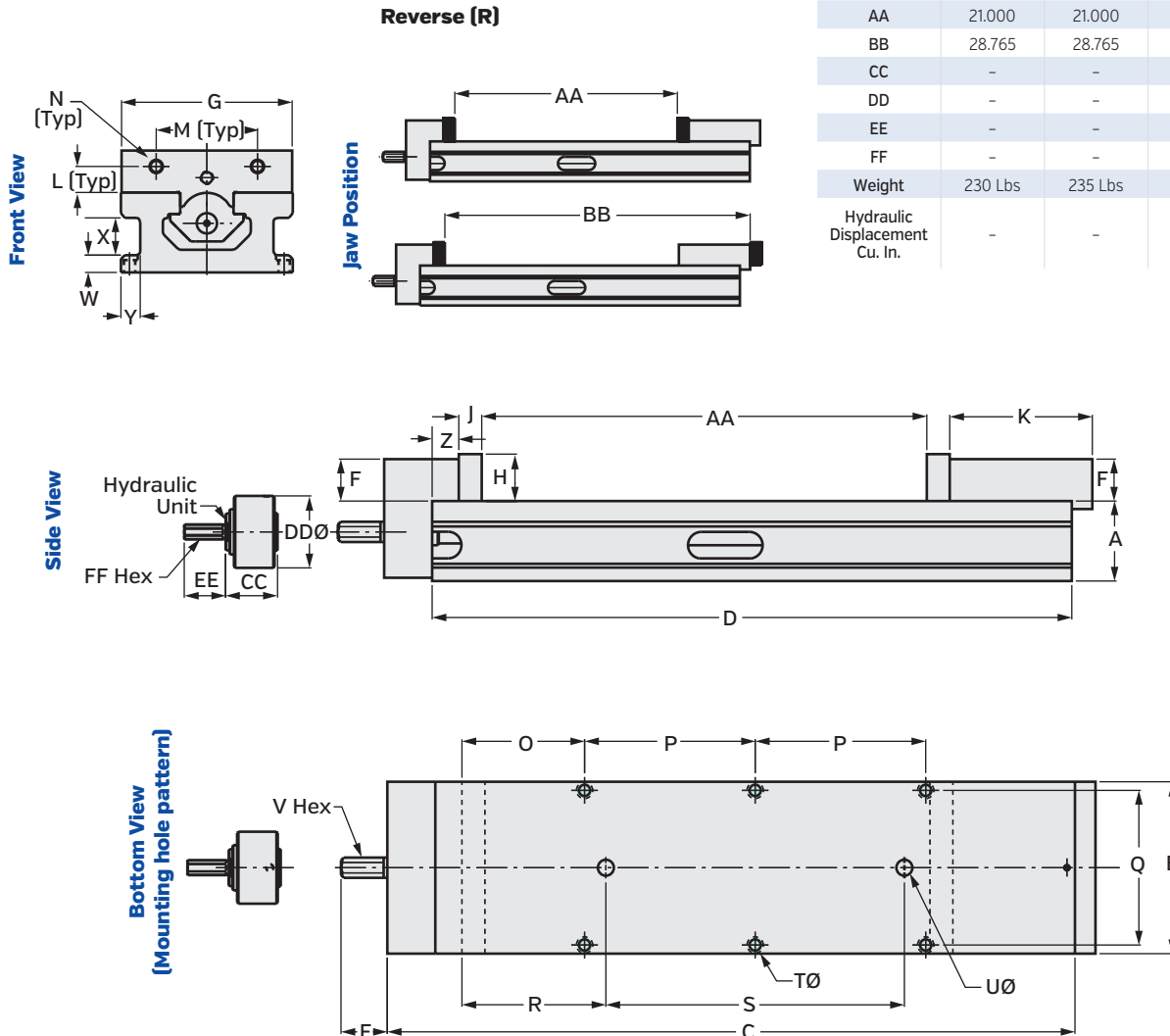

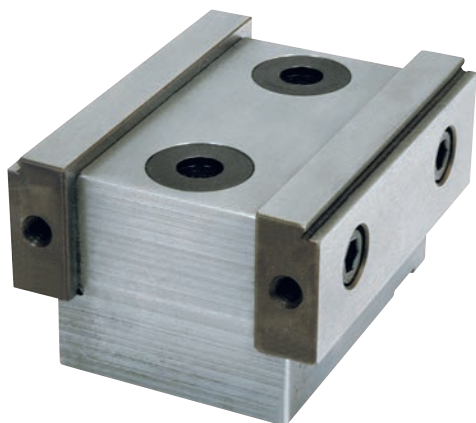

Stationary Jaw MLS351



Manual Movable Jaw ML35



Hydraulic Movable Jaw MLH35

MoveLock Modular System

This high precision two-piece vise is the first of its type to utilize the famous Kurt AngLock concept to prevent jaw lift during clamping. As power is applied to the piston, it is driven forward to locate on an internal segment. While the lateral force is clamping the part, downward pressure is being applied to the movable jaw, which minimizes or prevents part lift. For every pound of clamping force on the jaw, there is a half pound of force exerted down on the movable jaw.

Features:

- Movable and stationary jaws sold separately.
- Movable jaws are available in either manual or hydraulic actuation.
- May be used as a single or double station vise, and can be mounted side by side.
- Can be configured into high density fixturing. [See SeraLock pages 64-65]
- Features a 5/16" stroke.
- Mounts on a 2" x 2" grid system, T-slot sub-bases with a 2" pitch, standard sub-plates and machine tables and SeraLock system.
- Clamps large workpieces - jaw opening limited only by the work envelope.
- Light weight.
- Small footprint - 3.500" jaw width.
- Patented

Special jaw plates and workstops are available. Contact the factory for pricing and availability.

MLH35 Hydraulic Pressure To Clamping Force Chart		ML35 Torque/Clamping Force Chart	
Hyd. Pressure (PSI)	Clamping Force (Lbs)	Torque (Ft Lbs)	Clamping Force (Lbs)
400	200	5	750
800	500	10	1,550
1,200	850	15	2,600
1,600	1,200	20	3,550
2,000	1,550	25	4,450
2,400	1,850	30	5,400
2,800	2,150	35	6,300
3,200	2,500	40	6,900

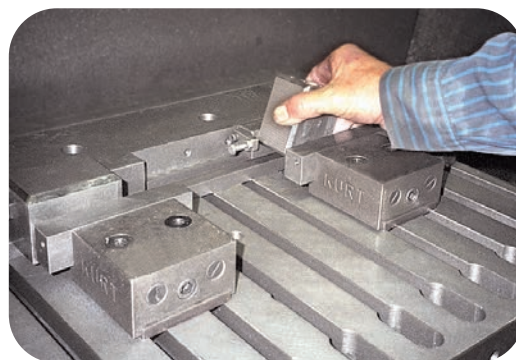

Stationary Jaw MLS351
Serrated Stationary Jaw SMLS351

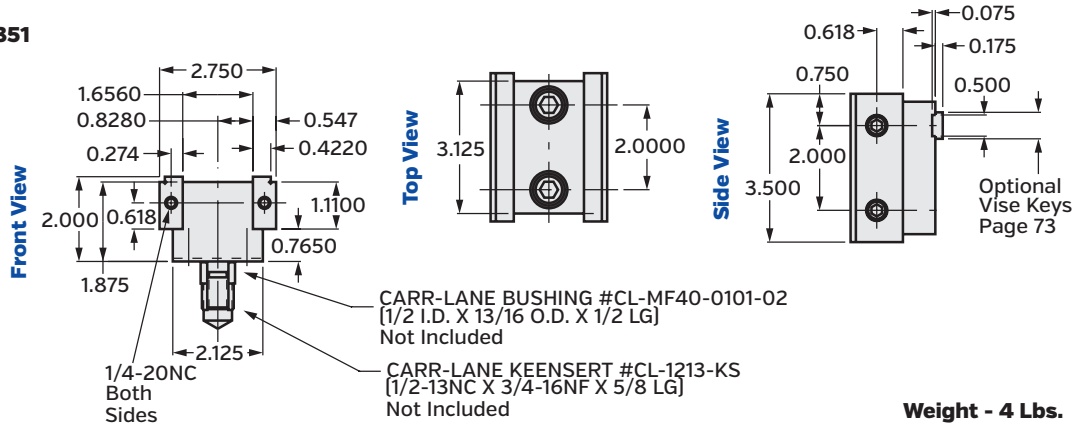
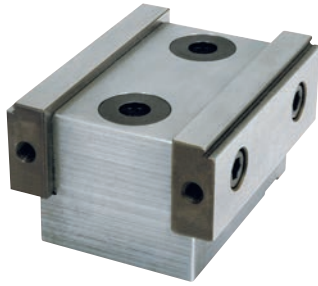

Manual Movable Jaw ML35
Serrated Manual Movable Jaw SML35

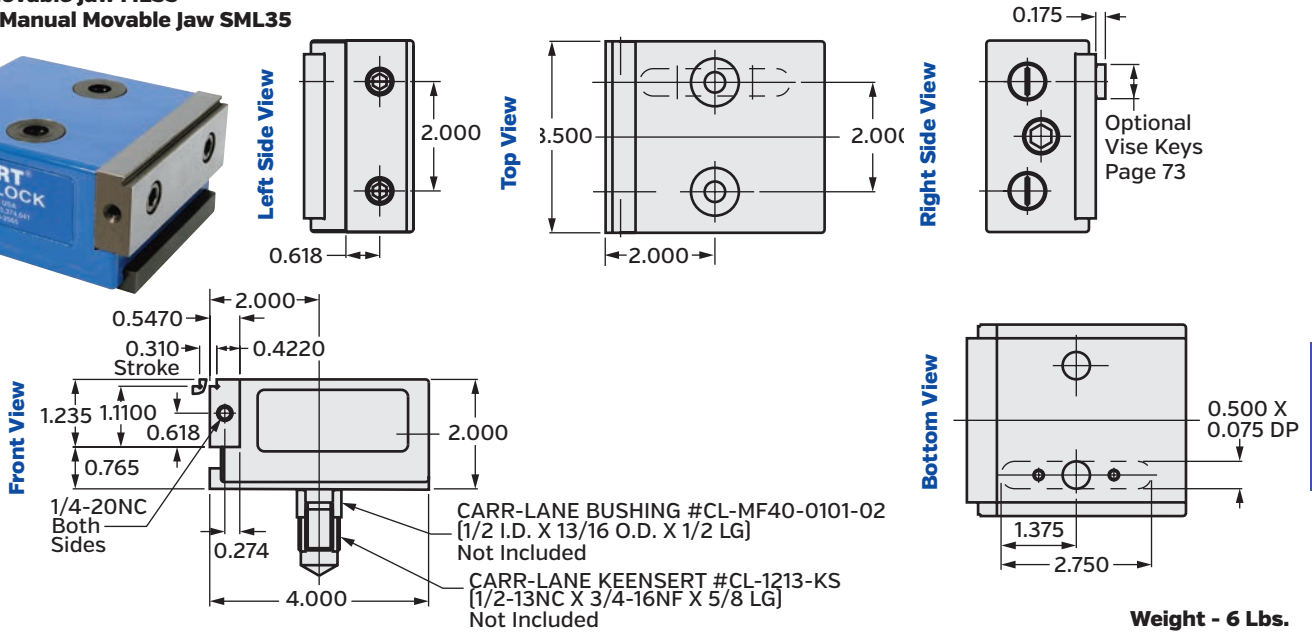

Hydraulic Movable Jaw MLH35
Serrated Hydraulic Movable Jaw SMLH35

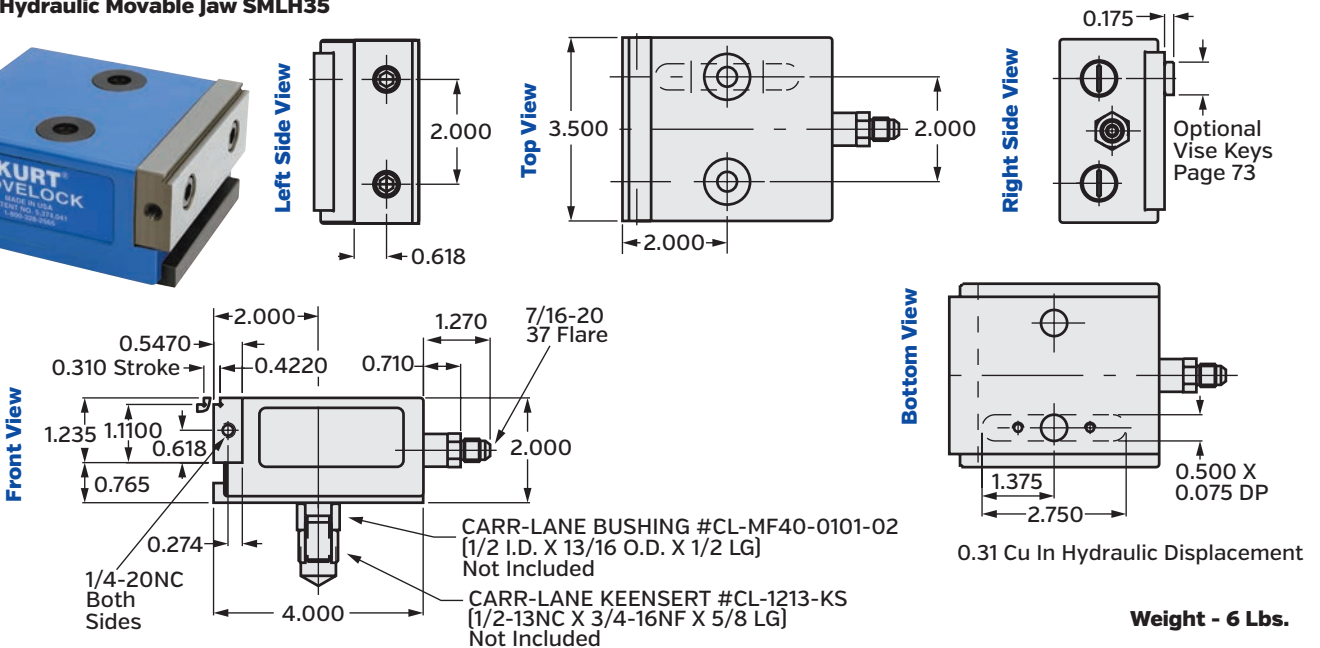

SeraLock® Foundations

SeraLock Tower Options

The SeraLock Towers, SeraLock Pallets, WedgeLock Module system and MoveLock Modular System are the latest innovation for achieving high density, highly repeatable part clamping.

SeraLock Towers and SeraLock Pallets are designed with interlocking "V" shaped serrated surfaces for precise and repeatable alignment of WedgeLock and MoveLock clamping modules.

SeraLock Towers are available in four sided, two sided and single sided towers with a base that will mount to your HMC or an indexer for VMC applications. SeraLock pallets are available in sizes that will accommodate most vertical machining centers. A custom, high density workholding system can be configured quickly when our WedgeLock modular system of single and double sided clamping jaws are used with the SeraLock Tower or SeraLock Pallet.

SeraLock features:

- Self-aligning.
- Multiple components may be used at the same time.
- Like and unlike workpieces may be machined all in the same setup.
- Mix and match components.
- Allows creation of the equivalent of a custom fixture in less time than the custom fixture can be designed.
- Modular components can be used over and over again.
- Very economical.

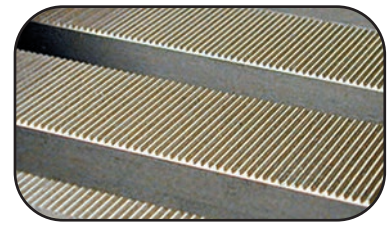

Tower & Base Options (Single)

Tower & Base Options (Double)

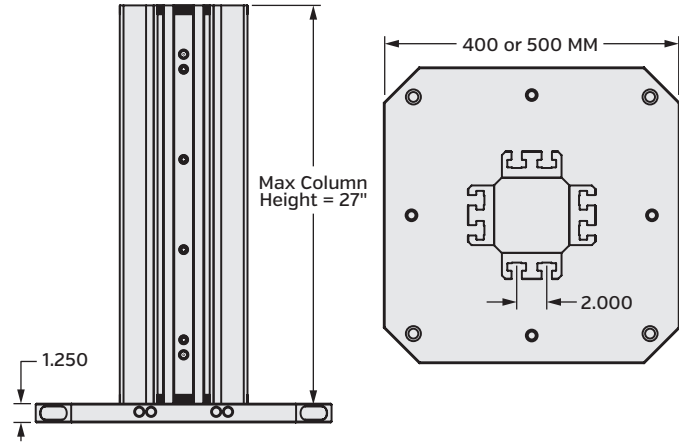
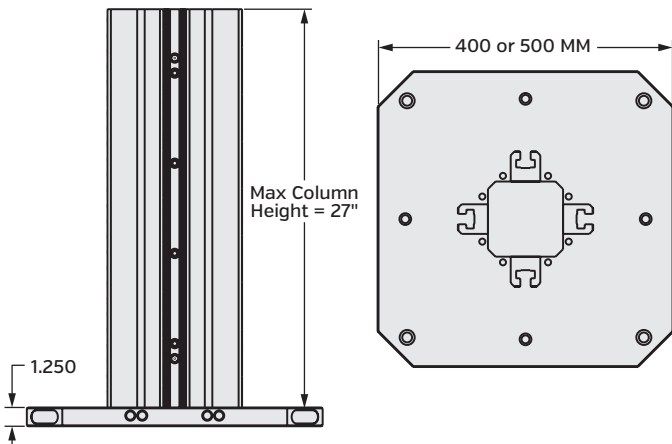

Pallet Length Options

Pallet T-Slot Options

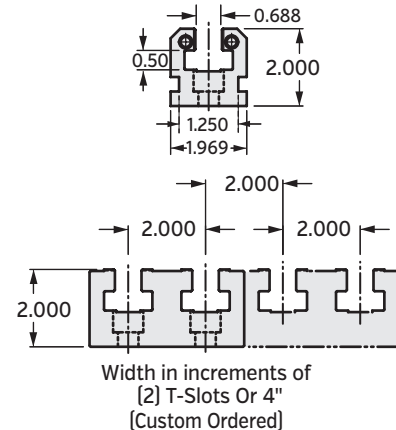
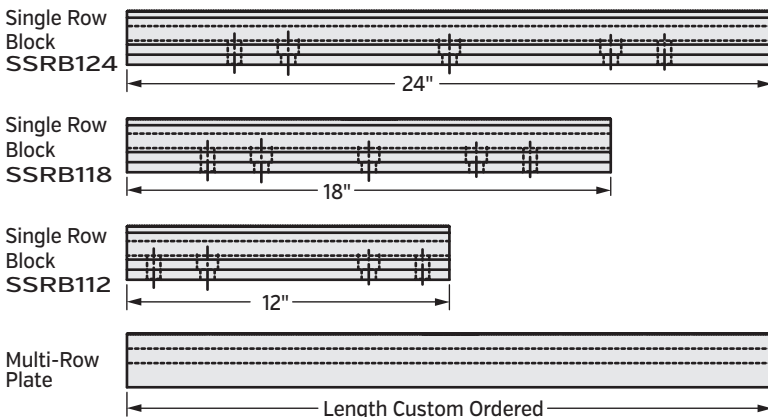

Serrated WedgeLock Clamping Modules

WedgeLock Clamping Options

SWSC1 Single Clamp

1.25 Wide Body. Contains stationary jaw on one side and movable jaw on back side.

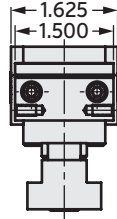
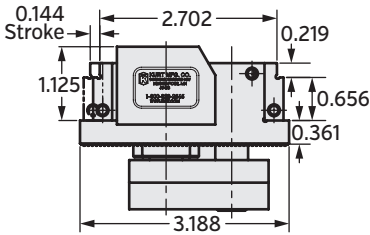

SWSC1

SWDC1 Double Clamp

1.25 Wide Body. Contains two movable jaws. Used with stationary block to become a high density workholding solution. Clamp two parts with one screw.

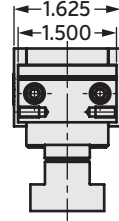
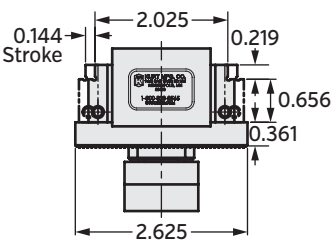

SWDC1

SWSB1 Stationary Block

1.25 Wide Body. Used with single or double clamp.

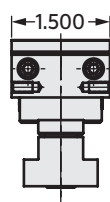
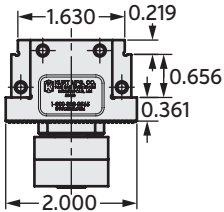

SWSB1

SWDSB1 Double Stationary Block

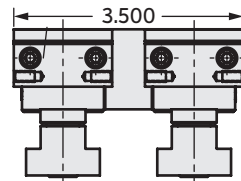
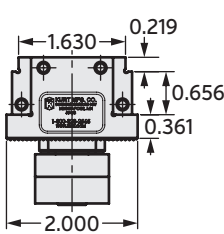

SWDSB1

SWDJ1 Dividing Jaw

1.25 Wide Body. Use in between movable and stationary jaw when milling several identical parts. Jaw floats to accommodate slight part difference. Allows several parts to be clamped with one movable jaw.

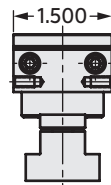
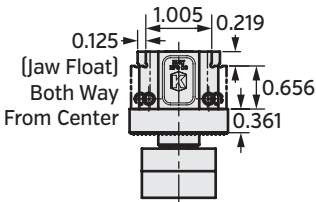

SWDJ1

Jaw Plates

Standard Length

SW1-7-SAMAG Flat Jaw Plate w/Magnet

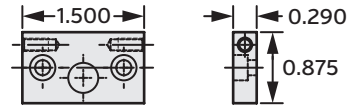

SWSC1-32A Stepped/Reversible Jaw Plate

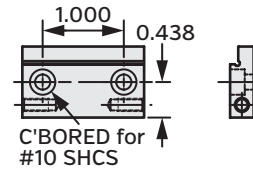

SW1-47-SAMAG Serrated Jaw Plate w/Magnet

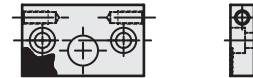

SW1-317 Carvable/Reversible Aluminum Jaw Plate

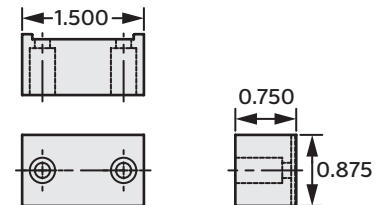

SW1-237 "V" Jaw Plate

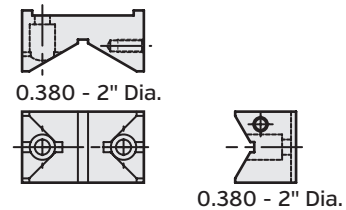

Clamping Force	
Ft. Lbs.	Lbs. Force
5	550
10	870
20	1,590
30	2,300
40	3,000



MoveLock System
see page 62



MiniLock

Unlike many competitive cam action models, this product employs the same AngLock concept as the world famous Kurt vises. When a quarter turn is applied to the screw, the split clamp jaw is forced both laterally and down, precisely clamping the part and preventing part lift at the same time. In-house tests showed zero lift when the MiniLock was used in several grinding operations.

Models: (Inch)
MT4 | MT5 | MT6 | MT8

Models: (Metric)
MTM4 | MTM5 | MTM6 | MTM8

Features:

- By using stationary blocks or pins, two parts may be clamped by a single MiniLock.
- The versatile MiniLock can be used in single holding, double holding or multiples of both single and double holding applications.
- Ideal for dedicated fixturing as well as for palletizing small parts to be loaded into receivers on machine tables.
- Through the use of a variety of locating blocks, workstops and MiniLocks, several similar parts or a part "family" can be located on a single pallet.
- Clamping jaw made from rugged Ampco 18 aluminum bronze.
- Actuating screw is made from a special alloy steel.
- While one pallet of parts is being machined, the operator can be unloading and loading a second similarly configured pallet away from the machine tool.
- Steps may be machined into the clamp jaw for operations that require parts to be raised above the pallet or machine table.
- The low profile allows for machining of complete top surfaces of parts without having to re-clamp.
- Conveniently uses standard thread sizes and standard hex keys.
- One MiniLock package contains six MiniLocks.
- Patented



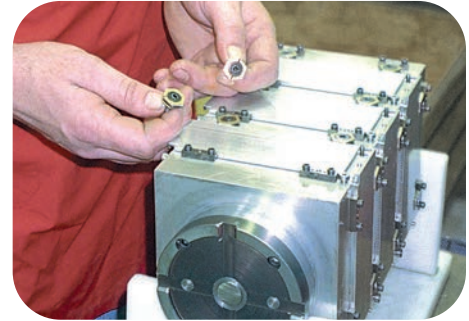
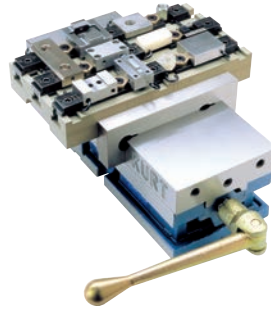
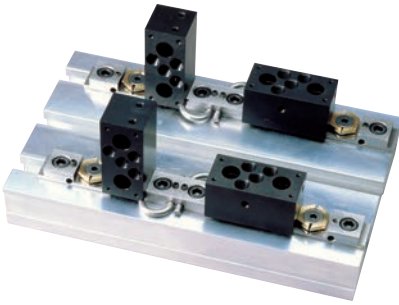

MiniLock											Optional C'Bored Tapped hole use for Larger part Tolerance Differential				Torque Ft. Lb.	Clamping Force Lbs.
Model Number	Hex Size	Hex Thickness	Screw Size	Hex Wrench Size	Screw Length	Suggested Tapped Hole Loc. From Edge of Part	Min. Distance From Screw CL	Max Distance From Screw CL	45° Thread Chamfer Dia.	Max part Size Differential Double Clamp	C'Bore Dia. +0.015-0.005 (-0.39-0.13mm)	C'Bore Depth +0.020 (-+50mm)	Max part Size Differential Double Clamp	Approx. Thread Engagement		
Inch Models																
MT4	0.688	0.188	1/4-20	0.156	0.625	0.324	0.308	0.350	0.300	0.010	0.281	0.156	0.020	0.250	11	987
MT5	0.875	0.250	5/16-18	0.188	0.750	0.412	0.384	0.442	0.368	0.010	0.344	0.203	0.020	0.283	18	1,400
MT6	0.938	0.312	3/8-16	0.218	1.000	0.439	0.400	0.482	0.437	0.010	0.406	0.375	0.020	0.307	30	2,200
MT8	1.125	0.375	1/2-13	0.312	1.250	0.528	0.492	0.584	0.500	0.010	0.531	0.468	0.020	0.384	83	2,600

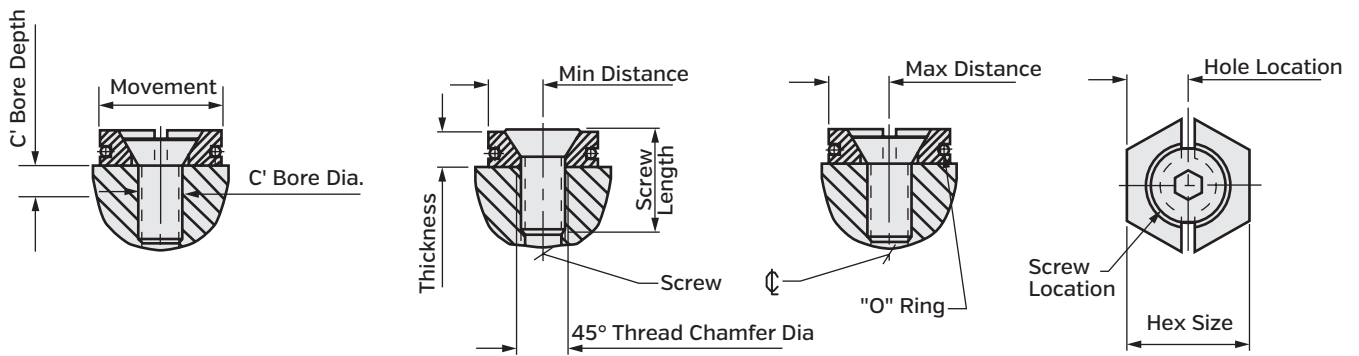

Option:

To allow a greater differential between workpieces, it is suggested you create a thread free zone to allow more sideways movement for the screw head.

Important Notice: Full thread is required when MiniLock is used clamping only on one side.

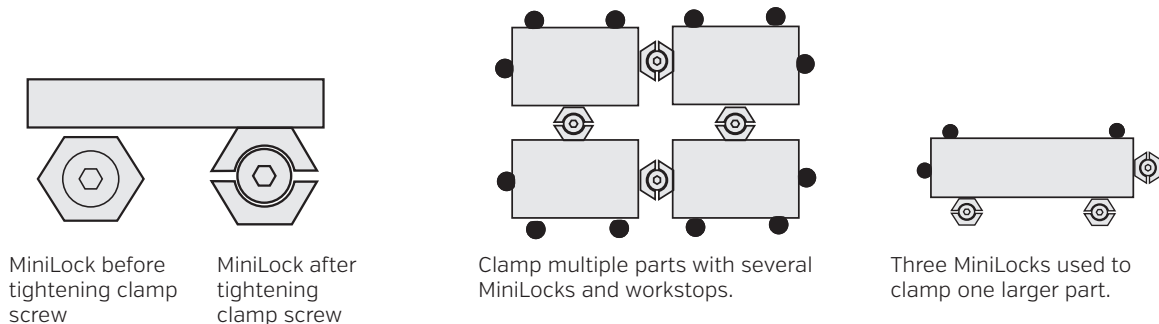

VB DockLock

The VB DockLock system is the original zero-point workholding system. The patented zero-point design increases productivity and reduces setup and changeover. The VB DockLock system integrates with new or existing workholding devices such as Kurt vises and fixtures, and provides fast, ultra accurate setup on machining centers. Time consuming setup, alignment and bolt down tasks are eliminated.

The system consists of a patented locking cylinder device that positions and locks the vise or fixture onto the machine worktable. It allows the user to locate or remove the workholding from a machine, or move it offline or to another machine and/or back again in just seconds with zero-point positioning accuracy every time. The system engages mechanically and disengages hydraulically or pneumatically.

For complete details request a copy of the VB DockLock catalog, or download a digital catalog at <http://www.kurtworkholding.com/downloads.php>

The leading zero-point workholding system on machining centers, proven in thousands of applications

Advantages:

- Set-up changes parallel to machining
- Work interruption possible at any time without losing "zero point"
- Zero-point repeat accuracy ± 0.0002 "
- 5 face processing without unclamping
- Further usage of existing fixtures
- Inexpensive plug for clamping and centering
- Dynamical, form-fit clamping
- Cylinders for direct integration into machine tables
- Built-in cylinders
- Built-up cylinders

Benefits:

- Lowers machine setup time by 90% and increases productivity
- Flexibility for urgent orders
- Interruption anytime without losing the zero-point
- Obstruction free machining
- Huge time and cost savings
- Simple mounting to fixtures, pallets or workpieces
- Improved surfaces, increased tool life and high security
- No distortion forces in the machining table
- Allow any configuration in spacing on plates, set-up tables and CMM's
- For a flexible arrangement on every machine

Comparison of average loss on set-up changes! (machining hour \$ 90.-)

Conventional

with VB DockLock

(a) Vise

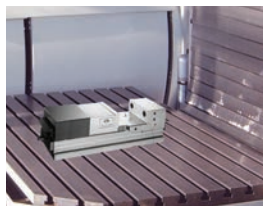

20 min. \$30.-

(b) Fixture



40 min. \$60.-

(a) Vise



2 min. \$3.-

(b) Fixture

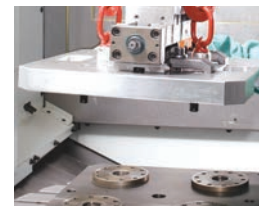

2 min. \$3.-

Increased efficiency with VB DockLock zero-point workholding system (assumption 200 working days) Based on Published Averages

(a) With Vise

Savings in One Year

	1 Machine	5 Machines	5 Machines
Savings \$27.00	1 Machine	5 Machines	5 Machines
With Every Change	1 Shift	1 Shift	3 Shifts
1 Set-Up Change Per Day	\$ 5,400	\$ 27,000	\$ 81,000
2 Set-Up Changes Per Day	\$ 10,800	\$ 54,000	\$ 162,000
4 Set-Up Changes Per Day	\$ 21,600	\$ 108,000	\$ 324,000

(b) With Fixture

Savings in One Year

	1 Machine	5 Machines	5 Machines
Savings \$57.00	1 Machine	5 Machines	5 Machines
With Every Change	1 Shift	1 Shift	3 Shifts
1 Set-Up Change Per Day	\$ 11,400	\$ 57,000	\$ 171,000
2 Set-Up Changes Per Day	\$ 22,800	\$ 114,000	\$ 342,000
4 Set-Up Changes Per Day	\$ 45,600	\$ 228,000	\$ 684,000

Only available through KURT in the Americas

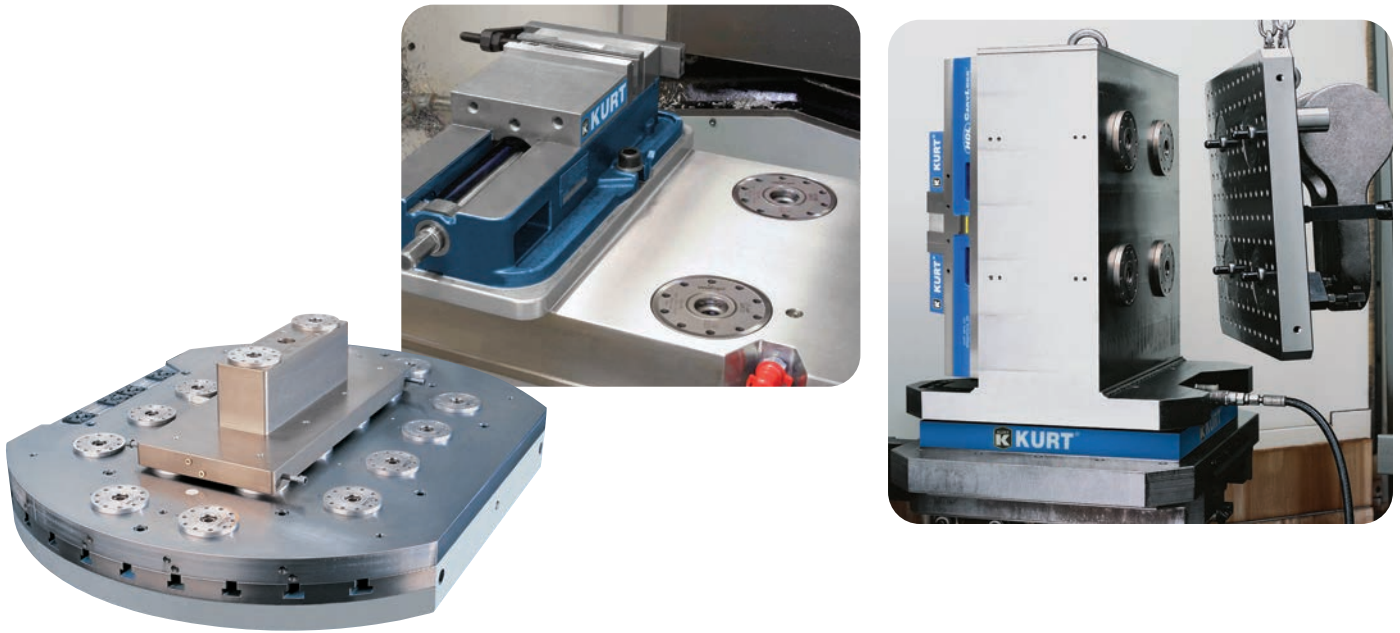

Fixtures / workpieces

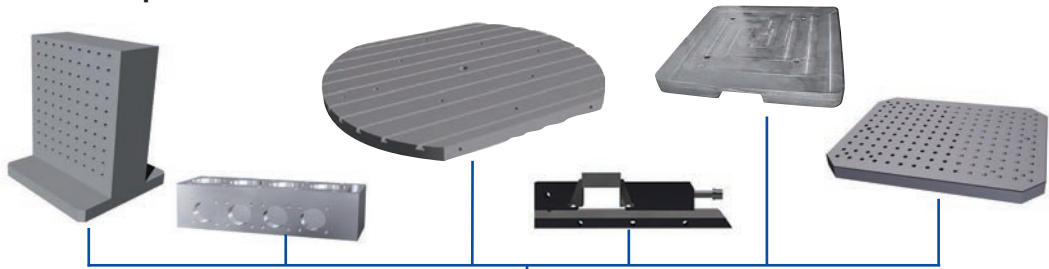

Plug mounting

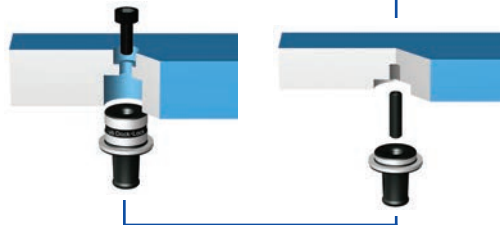

Integrated cylinders

Base plate with built-in cylinders

Built-up cylinders

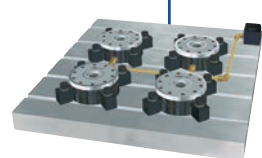
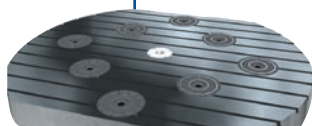

Machine level

Aluminum Master Jaw Kit
[DJ6 Shown]



Steel Master Jaw Kit
[DJ6S Shown]

DoveLock™ Quick Change Jaw System

Models available for 3.5", 4", 6", and 8" jaw widths

- Quick change for fast setups in under 1 minute. DoveLock jaws are changed from the top by loosening 3 quick-clamps. Jaws can be removed from the front or side.
- Workstop for position repeatability to $\pm 0.001"$.
- Aluminum jaws are machined not extruded.
- Jaws are machinable for part profile or steps.
- Jaws can be turned 180° to do 2 different setups.
- Master jaw set and jaw kits machined of 6061 aluminum. Steel master jaws and jaw kits are made of 4140 prehard.
- Patent Pending design.
- Fits all Kurt industry standard 3.5", 4", 6" & 8" vises and towers.

Master jaw set includes:

- 2 master jaws, 4 cap screws,
- T-handle hex key.

Jaw kits include:

- 2 jaws.

Jaw can be flipped 180° for 2nd setup

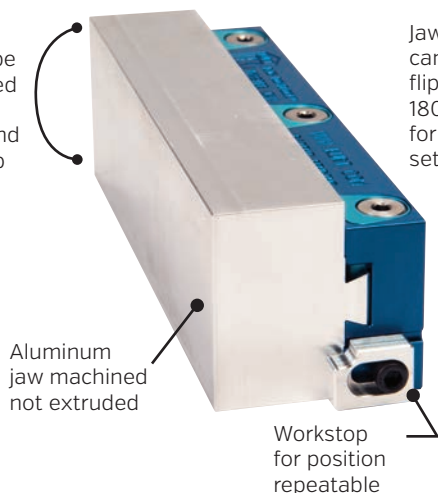

Jaw can be flipped 180° for 2nd setup

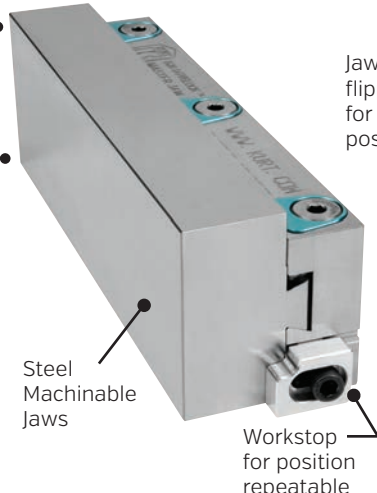

Jaw can be flipped 180° for higher position

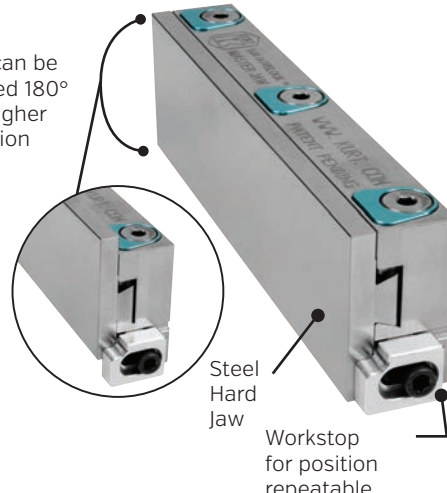

	Part Number	Length	Width	Height	Weight
3.5" AI	DJ3.5 Master Jaw Kit	3.500	0.630	1.250	1 Lb.
	DL3.5AL-JAWKIT	3.500	1.062	1.250	1 Lb.
4" Aluminum	DJ4 Master Jaw Kit	4.000	0.630	1.307	1 Lb.
	DJ4SK Starter Jaw Kit	4.000	N/A	N/A	3 Lbs.
	DJ404AL-JAWKIT	4.000	1.275	1.414	2 Lbs.
	DL406AL-JAWKIT	6.000	1.275	1.414	3 Lbs.
6" Aluminum	DJ6 Master Jaw Kit	6.000	0.775	1.725	2 Lbs.
	DJ6M (Metric) Master Jaw Kit	6.000	0.775	1.725	2 Lbs.
	DJ6SK Starter Jaw Kit	6.000	N/A	N/A	6 Lbs.
	DJ606AL-JAWKIT	6.000	1.250	1.980	4 Lbs.
	DJ607AL-JAWKIT	7.000	1.500	1.980	5 Lbs.
	DJ608AL-JAWKIT	8.000	1.500	1.980	6 Lbs.
	DJ610AL-JAWKIT	10.000	1.500	1.980	7 Lbs.
6" Steel	DJ606S-JAWKIT Machinable Steel Jaw Kit	6.000	1.000	1.980	7 Lbs.
	DJ6STFJ-JAWKIT Steel Hard Jaw Kit	6.000	0.250	1.715	2 Lbs.
8" Aluminum	DJ8 Master Jaw Kit	8.000	1.075	2.220	4 Lbs.
	DJ8SK Starter Jaw Kit	8.000	N/A	N/A	11 Lbs.
	DJ808AL-JAWKIT	8.000	1.475	2.450	7 Lbs.
	DJ810AL-JAWKIT	10.000	1.475	2.450	8 Lbs.

Starter Kits for Aluminum Jaws



DJ6HT T-Handle Hex Key



DJ6-35-SA



DJ6-45-SA



Machinable Aluminum Jaw Kits



Machinable Steel Jaw Kits



Steel Hard Jaw Kits



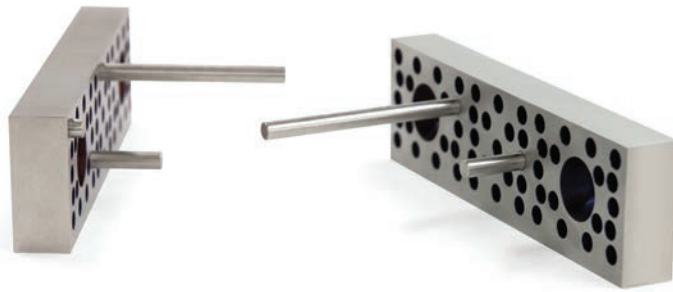

3-In-One System Jaw Plates

Models:
KSJ6 (for 6 Inch vise)
KSJ8 (for 8 Inch vise)

Features:

- Ideal for quick setups of common angle cuts.
- Preset patterns in jaws provide for these 7 popular angles: 5°, 10°, 15°, 20°, 25°, 30°, 45°.
- Tolerance between holes 0.0004" [0.01mm]
- Jaw dimensions:
KSJ6 6" x 1.735" x 0.725" ±0.000787" [±0.02mm]
KSJ8 8" x 2.20" x 1.075" ±0.000787" [±0.02mm]
- Pins Sets Included are:
 - 4 ea 6mm x 22mm
 - 3 ea 6mm x 40mm
 - 3 ea 6mm x 58mm
 - 3 ea 6mm x 76mm
- Pin Sets Dimensional Tolerance: ±0.0007" [0.018mm]
- Doubles as a convenient workstop, Triples as parallel. Does the work of 3 products.
- Made for Kurt in Sweden.
- Weights: **KSJ6** 4 lbs. / **KSJ8** 9 lbs.

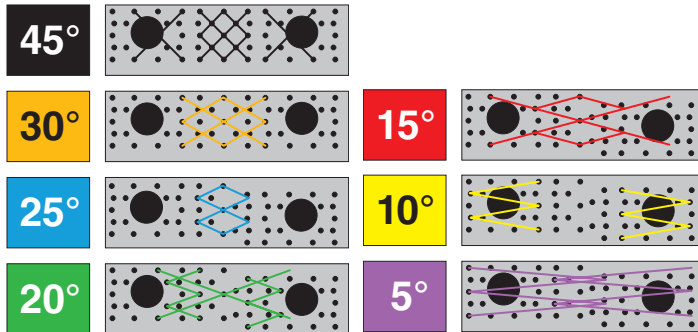

InnerLock Jaw Plates



With the InnerLock jaw plates, it takes only 40 seconds to change. By minimizing down time, the unique reversible feature saves you money on the jaw plates. Each jaw plate can be mounted in two directions, giving you two jaw plates for the price of one. For instance, the plain jaw plate when in the inverted position has a step for holding small parts closer to the spindle. Our small through-hole design allows for greater gripping surface.

InnerLock Individual Jaws	4" Vise		6" Vise		8" vise	
Jaw Type	Part #	Weight	Part #	Weight	Part #	Weight
Single Step	AJ400-32	1 Lb.	AJ600-32	2 Lbs.	AJ800-32	6 Lbs.
Double Step	AJ400-236	1 Lb.	AJ600-236	2 Lbs.	AJ800-236	5 Lbs.
Aluminum	AJ400-234	1 Lb.	AJ600-234	1 Lb.	AJ800-234	2 Lbs.
Semi-Hard Steel [4150]	AJ400-235	1 Lb.	AJ600-235	3 Lbs.		
Serrated	AJ400-47	1 Lb.	AJ600-47	2 Lbs.	AJ800-47	6 Lbs.
V Jaw Hardened & Ground	AJ400-237	2 Lbs.	AJ600-237	5 Lbs.	AJ800-237	10 Lbs.
*Bolts-D Pieces 2/Plate	00-3353	1 Lb.	00-3417	1 Lb.	00-3481	1 Lb.
*Bolts-PT Pieces 2/Plate	00-3353	1 Lb.	00-3417	1 Lb.	00-3481	1 Lb.
*Bolts-DL Pieces [Stationary] 2/Plate	00-3348	1 Lb.	00-3412	1 Lb.	-	-
*Bolts-DL Pieces [Movable] 2/Plate	00-3353	1 Lb.	00-3417	1 Lb.	-	-

Metric LHSCS For HDL Vises	Part #	Dimensions
HDL Series Vise - Movable [4]	AJ600-89	LHSCS M12 x 1.75 30mm Lg
HDL Series Vise - Stationary [4]	AJ600-143	LHSCS M12 x 1.75 16mm Lg

Part #	InnerLock Jaw Plate Dimensions																						
	Aluminum			Semi Hard			Single				Double Step				Serrated			V-Jaw					
	W	L	H	W	L	H	W	L	H	STEP	W	L	H	ST 1	ST 2	W	L	H	W	L	H	SMØ	LGØ
AJ400	0.730	3.969	1.374	0.730	3.969	1.374	0.570	3.969	1.374	0.125	0.547	3.969	1.374	0.250	0.500	0.547	3.969	1.374	1.125	3.969	1.374	0.100	1.500
AJ600	0.9810	5.969	1.880	1.125	5.969	1.880	0.725	5.969	1.880	0.188	0.735	5.969	1.880	0.375	0.750	0.725	5.969	1.880	1.875	5.969	1.880	1.125	3.000
AJ800	1.230	7.969	2.440	-	-	-	1.075	7.969	2.440	0.250	1.075	7.969	2.440	0.500	1.000	1.075	7.969	2.440	2.375	7.969	2.440	1.500	4.500

*InnerLock jaws require low profile cap screws (LPCS). Sold as each.

Machinable Aluminum Jaw Plate For All Kurt 6" Vises



XJAB6A-318

- 6" Aluminum [6061-T6] soft jaw. Fits all Kurt 6" vises.
- Reversible top to bottom and front to back, [Counter bore both sides].
- Extra thickness for carving part shapes into jaw plate.
- 5.969" L x 1.500" W x 1.874" H.
- Weight 2.00 Lbs

Standard Individual Jaw Plates

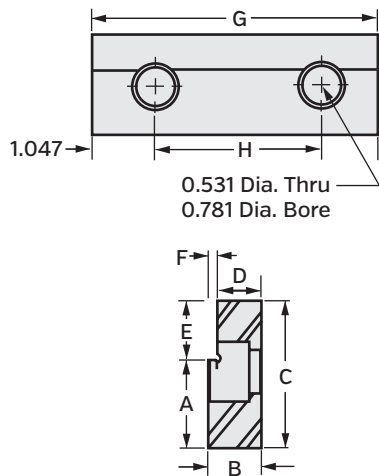

Part #	Dim "A"	Dim "B"	Dim "C"	Dim "D"	Dim "E"	Dim "F"	Dim "G"	Dim "H"	Description	Weight
D40-7	N/A	0.547	1.235	N/A	N/A	N/A	3.969	2.500	Std. Hard Jaw	1 Lbs.
D40-7 SOFT	N/A	0.562	1.250	N/A	N/A	N/A	3.969	2.500	Std. Soft Jaw	1 Lbs.
D60-7	N/A	0.725	1.735	N/A	N/A	N/A	5.969	3.875	Std. Hard Jaw	2 Lbs.
D60-7 SOFT	N/A	0.735	1.750	N/A	N/A	N/A	5.969	3.875	Std. Soft Jaw	2 Lbs.
60-32-1	1.693	0.725	1.880	0.610	0.187	0.115	5.969	3.875	Std. Step Jaw	2 Lbs.
60-236-1	1.505	0.725	1.880	0.610	0.375	0.115	5.969	3.875	Std. Step Jaw	2 Lbs.
60-236-2	1.130	0.725	1.880	0.610	0.750	0.115	5.969	3.875	Std. Step Jaw	2 Lbs.
*60-234-1	N/A	0.980	1.880	N/A	N/A	N/A	5.969	3.875	Aluminum	1 Lbs.
*60-235-1	N/A	1.125	1.880	N/A	N/A	N/A	5.969	3.875	4140 Pre-Hard	3.5 Lbs.
LP60-32	1.469	0.725	1.635	0.610	0.166	0.115	5.969	3.875	Low Profile Step Jaw	2 Lbs.
*60-47-1	N/A	0.725	1.735	N/A	N/A	N/A	5.969	3.875	Std. Serrated	2 Lbs.
D80-7	N/A	1.105	2.200	N/A	N/A	N/A	7.969	4.750	Std. Hard jaw	5 Lbs.
D80-7 SOFT	N/A	1.105	2.200	N/A	N/A	N/A	7.969	4.750	Std. Soft Jaw	5 Lbs.
D100-7	N/A	1.320	2.937	N/A	N/A	N/A	10.125	5.750	Std. Hard Jaw	6 Lbs.
D100-7 SOFT	N/A	1.350	2.957	N/A	N/A	N/A	10.125	5.750	Std. Soft Jaw	6 Lbs.
D100-47	N/A	1.375	3.000	N/A	N/A	N/A	10.125	5.750	Std. Serrated	6 Lbs.

*60-234-1 is a carve your own pocket jaw plate.
 *60-235-1 is a carve your own pocket jaw plate.
 *60-47-1 Serrations are aggressive and will mark parts.

8" Parallel Sets (IMPORTED)



8PS6 6 Pair Set Features:

- 1.000", 1.250", 1.500", 1.750", 2.000", 2.125" Heights.
- 0.250" ±0.002" Thickness.
- 0.0002" Parallelism.
- Hardened RC 52-58
- 1 ea. Plastic storage box.
- Weight 12 Lbs.

8PS9 9 Pair Set Features:

- 1.000", 1.250", 1.375", 1.500", 1.625", 1.750", 1.875", 2.000", 2.125" Heights
- 0.250" ±0.002" Thickness.
- 0.0002" Parallelism.
- Hardened RC 52-58
- 1 ea. Plastic storage box.
- Weight 17 Lbs.

8" Parallel Sets	
Part #	Description
8PS6	6 Pair Set
8PS9	9 Pair Set

6PJS Magnetic Jaw Plate and Parallel Set (Imported)

This 6" magnetic jaw set from Kurt comes complete with two jaw plates with an embedded rare earth magnet for holding the parallels in place, leaving hands free to hold and clamp the workpiece. Genuine Kurt Groove Lock workstops are also included, all in it's own convenient plastic storage box. Patented



This 11 Piece Set Includes:

- 2 ea. 3/16" x 1" x 6" ground steel parallels.
- 2 ea. 3/16" x 1-1/4" X 6" ground steel parallels.
- 2 ea. 3/16" x 1-1/2" x 6" ground steel parallels.
- 1 ea. D60-7-SAMAG hardened jaw plate with rare earth magnet.
- 1 ea. D60-315-SAMAG hardened Groove Lock jaw plate with rare earth magnet.
- 1 ea. WSRL46 Kurt Groove Lock workstop.
- 1 ea. WSRLE46 Kurt Groove Lock extended workstop.
- 1 ea. plastic storage box.

Features:

- Fits all Kurt 6" vises.
- Powerful rare earth magnets hold the parallels in place securely.
- Genuine Kurt Groove Lock workstops are included.
- Storage box helps keep you organized.
- Ground steel jaw plates and parallels.
- 8 Lbs.

6" Magnetic Jaw Plates

Features powerful rare earth magnets for holding parallels securely in place, leaving hands free to hold and clamp the workpiece. Fast and accurate set-ups. Patented



6" Magnetic Jaw Plates				
Part #	Description	Length	Width	Height
D60-7-SAMAG	6" Magnetic Jaw Plate	5.969	0.725	1.735
D60-315-SAMAG	6" Magnetic Jaw Plate Accepts Groove Lock Workstops	5.969	0.725	1.735

Workstop sold separately

Groove Lock® Reversible Style Step jaw plates

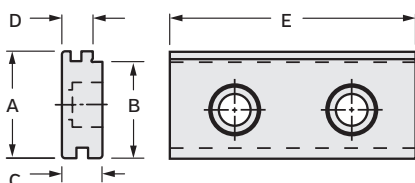

Reversible Style Step Jaw Plates						
Vise Size	Part #	Dim "A"	Dim "B"	Dim "C"	Dim "D"	Dim "E"
4"	D40-316	1.374	1.250	0.672	0.547	3.969
6"	D60-316	1.880	1.700	0.735	0.547	5.969

Groove Lock® Workstop



D60-315



WSRL46



WSRLE46

Features:

- Simple, functional, integral workstop system.
- Workstop does not interfere with part or spindle.
- Single bolt design for tightening workstop.
- Multiple parts can be located on the same jaw plate.
- Patented

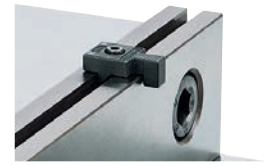

Item	Part #	Description
1	WSRL46	Workstop assembly, suitable to use with 2" thru 6" jaw plates
2	WSRLE46	Extended length workstop assembly, suitable to use with 4" thru 6" jaw on outside. Can be used on right or left end of jaw. Note: To use in center of jaw length, locating ear must be shortened to clear the top of the stationary jaw area.
3	D60-315-P	6" Groove Lock jaw plate [Not reversible] 1.735 x 0.7250 x 5.969
4	D40-315	4" Groove Lock jaw plate [Not reversible] 1.235 x 0.5470 x 3.969
5	WSRL46-86-SA	Replacement clamp assembly

All items sold separately

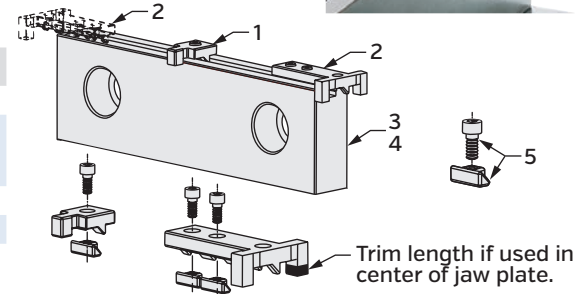

Trim length if used in center of jaw plate.

Vise Keys



Sold in pairs

Hardened vise keys are used to align your Kurt vise to your milling machine table. Step keys are used when the keyway in the vise is different than that of the machine T-slot. Standard keys are used when they are the same width.

Hardened Standard Keys (Pair)			Hardened Step Keys (Pair)		
Vise Model	Key Size	Part #	Vise Model	Key Size	Part #
4" Vise	1/2 x 1/2	D30-50	4" Vise	1/2 x 5/8	D30-33A
6" Vise	11/16 x 11/16	D50-50	6" Vise	11/16 x 5/8	D50-33A
8" & 10" Vises	13/16 x 13/16	D80-50		11/16 x 13/16	D50-33B
				11/16 x 3/4	D50-33C
				11/16 x 9/16	D50-33D
			11/16 x 1/2	D50-33E	
Hardened Metric Keys (Pair)			8" & 10" Vises	13/16 x 7/8	D80-33A
Vise Model	Key Size	Part #		13/16 x 11/16	D80-33B
4" Vise	1/2 x 18 mm	D30-33M18		13/16 x 3/4	D80-33C
6" Vise	11/16 x 16 mm	D50-33M16		13/16 x 5/8	D80-33D
6" Vise	11/16 x 18 mm	D50-33M18			
8" Vises	13/16 x 16 mm	D80-33M16			
8" & 10" Vises	13/16 x 18 mm	D80-33M18			

Sine Keys (Non-Expandable O-Ring Style)

• 32-37 RC Hardness



Rectangle Style

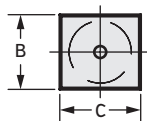
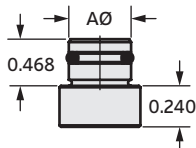

Round Style Diamond Style

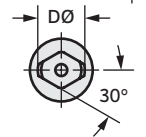
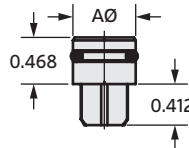
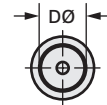
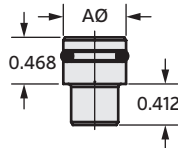

Sine Keys - Non-Expandable O-Ring Style - English (Each)

P/N	Style	AØ	B	C	DØ
SKOA8.9	Rectangle	0.6250	0.4995	0.5620	
SKOA10.11	Rectangle	0.6250	0.6245	0.6870	
SKOA12.13	Rectangle	0.6250	0.7495	0.8120	
SKOA14.16	Rectangle	0.6250	0.8745	0.9995	
SKOA8RD	Round	0.6250			0.4998
	Diamond	0.6250			0.4998
SKOA10RD	Round	0.6250			0.6250
	Diamond	0.6250			0.6250

Sold in pairs

Sine Keys - Non-Expandable O-Ring Style - Metric (Each)

P/N	Style	AØ	B	C	DØ
SKOAM14.16	Rectangle	0.6250	14mm	16mm	
SKOAM18.20	Rectangle	0.6250	18mm	20mm	
SKOAM20.22	Rectangle	0.6250	20mm	22mm	

Sold in pairs

Swivel Base



T-Bolt and Washer

Swivel Base			
Part #	T-Bolt and Washer	Fits These Vise Models	Weight
D40-4-SA	D40-27-SA	D40	16 Lbs.
D50-4-SA	D50-27-SA	DX6, HD690	20 Lbs.
D60-4-SA	D60-27-SA	D60, D675, D688	26 Lbs.
D80-4-SA	D80-27-SA	D80, D810	80 Lbs.

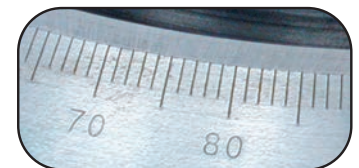

Swivel base allows positioning in 1 degree increments.

2MWS Magnetic Workstop



Features:

- Fast, accurate positioning of parts.
- Rare earth magnet attaches anywhere on the workholding setup without the need for connecting bolts or screws.
- Removes quickly to clear spindle travel when necessary.
- 12 Lbs of pull.
- Body is 2 5/8" long with 2" adjustable stop pins on both ends of body.
- Ideal for single, multiple station vises and high density workholding setups.
- 1 Lb. weight.

AngLock Workstop



Versatile, quick mounting workstops will work above jaws when gang mounting vises and space for a workstop does not exist. These Kurt workstops permit fast, accurate positioning on repetitive work. They team up with your AngLock precision vise for accurate parts production.



AngLock Vise Workstops		
Part #	Vise Size	Weight
D30-45	4" Vise	1 Lb.
360PWS	6" Vise	3 Lbs.
D80WS	8" Vise	4 Lbs.

6AWS Workstop

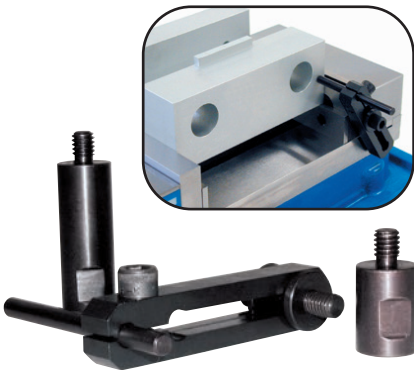

New adjustable workstop can be used on all Kurt high-density vises. The body clamp has a 2" adjustment and features a 3" long stop pin for fast and easy set-ups. A long and short spacer is also available to fit almost any application.

Features:

- Versatile.
- Economical.
- Fast, easy set-up.
- Black oxide finish.
- Fast accurate positioning of parts.

Workstops	
English Vise 5/16-18	Metric Vise m8 x 1.25
6AWS-Kit	6AWSM-Kit
6AWS Workstop	6AWSM Workstop
6AWS-288 1" Short Spacer	6AWSM-288 25.4mm Short Spacer
6AWS-289 2" Long Spacer	6AWSM-289 50.8mm Long Spacer

Kits include the workstop and both long and short spacers.

Parallel Keeper

Models:
KPS-6000
KPS-8000

Place your parallels in the vise against the jaws. Take the Parallel Keeper, squeeze it together and place it inside the parallels. Release the Parallel Keeper, it will push against the parallels, holding them against the jaws of the vise. It's that simple! KPS-6000 model opens to 6" and has an overall size of 8" x 14". KPS-8000 model opens to 8" and has an overall size of 10" x 14". Your new revolutionary labor saver, your "machinists third hand," is at work, saving part change time. 1 Lb. weight.



Shown with 3610V

Kurt Speed Handle D60SH



The Kurt Speed handles reduce set-up and clamp times. The **D60SH** with a 3/4" internal hex will fit all our 6 inch model vises. Our handles do not interfere with the milling machine giving you rapid part loading and unloading. You get Kurt's quality in a custom steel designed product. There is no aluminum hex to strip. 4 Lbs.

Kurt Torque Handle TH6



The Kurt Torque Handle provides repeatable clamping for small delicate parts. The Torque Handle fits a 3/4" Hex and gives you a precise feel while providing an audible "click". The small 10-3/4" overall length will not interfere with most table set-ups and the steel construction will give you the versatility and reliability demanded by today's modern machine shops. A set screw allows your Torque Handle to become an integral part of your vise. 4 Lbs.

Torque Vs. Position				
Position	1	2	3	4
Torque Ft. Lbs.	6	8	10	20

Torque Tolerance ±2 Lbs.

Replacement Vise Handles



Kurt original equipment handles are solid cast iron for strength and durability and are plated for rust protection. The handle portion is one-piece with a cast ergonomic ball on the end.

Part #	Hex	Length
D40I-10-SA	9/16	6 in.
D60I-10-SA	3/4	8-5/8 in.
D80I-10-SA	7/8	16-1/8 in.
D100I-10-SA	1	16-1/8 in.

KH6 and KH8 Handle Hangers

Never lose a vise handle again. New Kurt Vise Handle Hanger.

- Models KH6 [for 6" handles] and KH8 [for 8" handles]
- Made from high strength Thermoplastic
- Mount to workbenches, tool carts, cabinets or any surface near machine tables.
- Creates a convenient holding spot for quick access to vise handles.



Vise Screw Hex Extension



Features:

- Vise screw hex extensions become useful when the vises are mounted on large machines where extending the hex will allow better access.

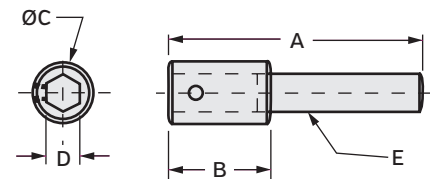

Vise Screw Hex Extension								
Vise Size	Handle Size	Part #	Dim "A"	Dim "B"	Dim "C"	Dim "D"	Dim "E"	Weight
6"	6	HEX6	5.000	2.000	1.250	0.750	0.750	1 Lb.

Spanner Wrench

Model No. DL430-307-SA – 4"
Model No. DL640-307A-SA – 6"

Features:

- Adjust the preload on your Kurt DoubleLock vise simply and quickly
- All Aluminum
- Knurled end for better grip
- Two models available: 4" and 6"





KHP3 Pneumatic/Hydraulic Pumps

Kurt's KHP3 Hydraulic pump is powered by normal shop air versus an electric motor. The pump uses 40-100 psi input pressure and sustains up to 3,400 psi of constant pressure into the hydraulic vises.

The KHP3 pump uses an internal load-limiting valve for protection against overload, a common problem with other hydraulic pumps. The special load-limiting valve allows the piston mechanism to cycle automatically when the systems ask for hydraulic flow at low pressures. This performance-on-demand feature keeps the pump pressurized and ready to give hydraulic flow whenever it is needed.

Other features:

- Air exhaust muffler for noise suppression
- Compact foot-print of the pump is 6" x 8"
- Each pump kit comes with all the necessary fittings, oil and choice of foot switch or hand switch.
- Weight: KHP3 = 21 Lbs., KHP3H = 26 Lbs., KHP3F = 31 Lbs., KHP3T = 25 Lbs.
- Useable Oil Volume is 75 Cu. In.

KHP3 Complete Pump Shown



KHP3H Complete Pump and Hand Kit Shown



KHP3F Complete Pump and Foot Kit Shown



KHP3T Toggle Pump Shown

Flow and Pressure Performance Guides

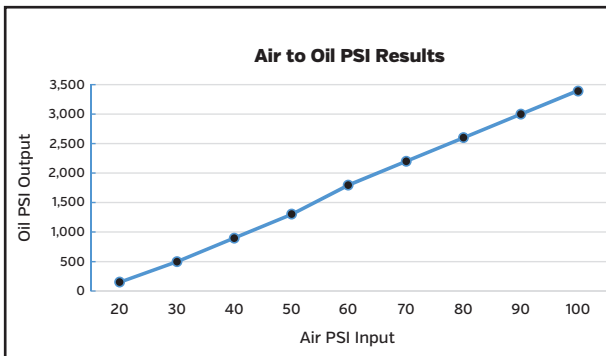
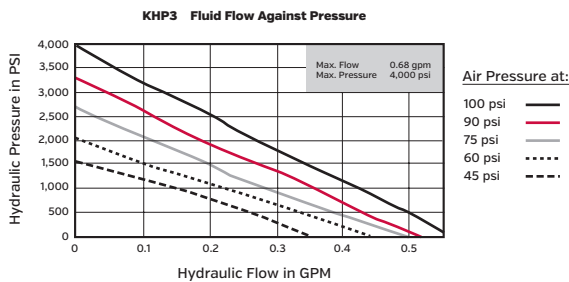

Air PSI Input	Oil PSI Output
20	150
30	500
40	900
50	1,300
60	1,800
70	2,200
80	2,600
90	3,000
100	3,400



Hydraulic Pump Components for Automation

(Sold Separately)

The Kurt automation pump system is custom configurable to match customer applications. It features fully integrated design for plug & play operation. Just add the appropriate connectors that fit your specific CNC controller or other I/O device.

Solenoids (Sold Separately)

- Poppet-type, "leak free," up to 350 bar [5100 PSI], 24V DC
- D03 Valve Mounting Pattern, mounting hardware included
- Wire connector not included [See KHS-391]



KHS-379 Solenoid Double Acting



KHS-381 Solenoid Normally Open



KHS-380 Solenoid Normally Closed

Valve Blocks (Sold Separately)



KHM4-303-SA 4 Valve Manifold Block



KHM2-303-SA 2 Valve Manifold Block



KHM-53-SA Cover

- D03 Valve Mounting Pattern [top]
- Pressure and Return ports on 3 sides
- Actuated ports on remaining side
- Mounting hardware included

Pressure Switch and Wire Connectors (Sold Separately)



- KHM-386 Pressure Switch**
- SAE 4 Male Port
 - Pressure Adjustment Range: 250-5500 PSI
 - Electrical Rating: -10 amp @ 125/250 VAC, -10 amp @ 12/24 VDC
 - Wire connector not included - [See KHM-391]



- KHM-391 Wire Connectors**
- M12 connector, 15' cord
 - For use with KHM-386 Pressure switch



- KHS-391 Wire Connectors**
- ISO connector, 15' cord, lighted
 - 24V DC, 50/60 HZ
 - For use with KHS-379, -380, and -381

KHP5000 Hydraulic Pump



- Dump Pump for single acting systems
- 1 HP Motor, 115/208-230 VAC
- Max Amps 11.1 @ 5,000 PSI
- External safety relief is user adjustable from 500-5,000 PSI
- Internal safety relief set at 5,000 PSI
- Auto dump valve
- 127 Cu. In. [0.54 gal] total capacity
- 75 Cu. In. [0.32 gal] usable capacity
- Weight 82 Lbs
- Average Pump Output Volume 31.3 Cu. In.

KHP5000BP Hydraulic Pump



- Demand Pump for double or single acting systems
- 1 HP Motor, 115/208-230 VAC
- Max Amps 11.1 @ 5,000 PSI
- External safety relief is user adjustable from 500-5,000 PSI
- Internal safety relief set at 5,000 PSI
- Auto dump valve
- 127 Cu. In. [0.54 gal] total capacity
- 75 Cu. In. [0.32 gal] usable capacity
- Weight 82 Lbs
- Average Pump Output Volume 31.3 Cu. In.
- Does Not Include Foot Pedal
- Optional 3-Way Valve [Part #KDC-M035NS]

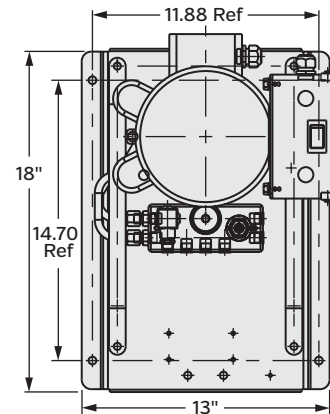
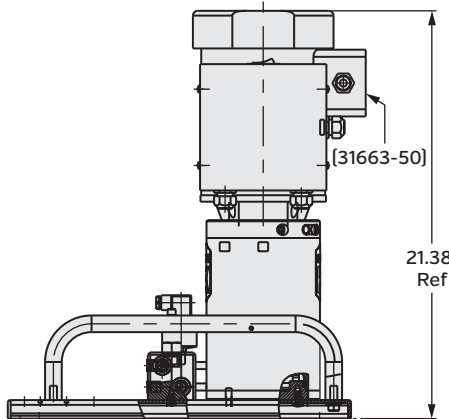

Overview of pump styles:

Dump Pump: Generally used where the fixture is to be disconnected from the pump for cycling. Most commonly used with a "pallet" valve. Run the pump with the foot valve until clamped and then close the pallet valve and release the foot valve.

Demand Pump: Used where the fixture will stay connected to the pump during the cycle. If the pump loses approximately 200PSI of pressure then it will start back up on its own to bring up the pressure to the set level. Move the lever forward to pressure up and clamp. Pull the lever back to release the pressure.

Note: The Kurt KHP5000BP pump is used with the Kurt KDC-M035NS directional control valve (sold separately) if the customer does not have their own.

Kurt Hydraulic Pump Chart

Part Number	Pump Type		Actuation	Max PSI	Usable Oil Cap. C.U.	Single Acting Systems	Double Acting Systems	Power Type	Wt. Lbs.
	Demand	Dump							
KHP5000		X	Foot	5,000	75	Y	N	115/208-230 VAC	82
KHP5000BP	X		Hand	5,000	75	Y	Y	115/208-230 VAC	82
KHP3F	X		Foot	3,400	85	Y	N	Pneumatic	31
KHP3H	X		Hand	3,400	85	Y	N	Pneumatic	26
KHP3T	X		Toggle	3,400	85	Y	N	Pneumatic	25

KHP5000PF-KIT Optional Vise Connection Kit

Kurt Part #	Qty	Unit	Description
1HLZ8	1	Each	Coupler, Male, Air
219-00-RM	5	Foot	Tubing, Polyethylene, 1/4"
226-02	2	Each	Fitting, 1/4", Straight
312.06	1	Each	FRL W/ Gage, Micro-Fog MOD
APD50-309	1	Each	#4 SAE Fitting, 7/16-20UNF
APD60-109-1	1	Each	Fitting, 1/4"-18, Straight
APD60-109-2	1	Each	Fitting, 1/8"-27, Straight
AT-L4	1	Each	Oil, Air Tool

KDC Series Directional Control Valves

**Model: KDC-M035NS KDC-M045NS KDC-M075NS
KDC-M143NP KDC-M173NP**

KDC Series valves are constructed of heat treated alloy steel and aluminum components. They are compact, lightweight (12 oz.) and shift easily even under maximum pressure. The valves have extremely low leakage, less than one (1) drop per two (2) minutes at rated pressure.

The working pressure rating available is 6,000 psi. The CV factor is .26 for the -4 SAE. Temperature range is -40°F to + 160°F. The manifold mounting conforms to D03 mounting pattern. For panel mounting, the hole should be 1-13/32" diameter and with a maximum thickness of 5/16".

The -7 configuration manipulator provides a special 4 way flow pattern which is ideal for pilot applications. In the neutral position, P is blocked and A and B are connected to tank. There is a restriction in neutral between A, B and tank, and this valve cannot be used where return flow through A and B is high.

High strength mounting bolts are included with the manifold mount version valve.

The KDC Series valves are used in a broad range of OEM applications, including instrumentation systems for power plants, jet engine transport trailers and testing systems.



3-Way



4-Way

KDC Valves Configuration

Series	Pressure Rating PSI	Port Location	Flow Configuration	Port Size	Seals	Panel Mount
KDC	M 6,000	0 Manifold	3 3 Way	3 -4 SAE	N Nitrile	S Standard
		1 Side	4 4 Way Closed	4 Manifold		P Panel
			7 Manipulator			

-3 3 Way

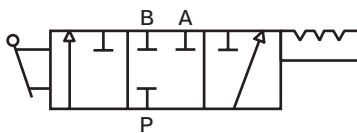

-4 4 Way Closed Center

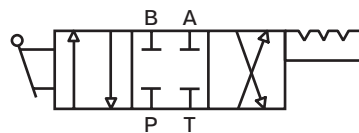

-7 4 Way Manipulator

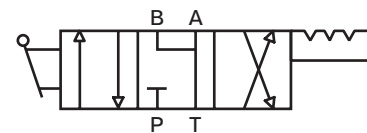

Side Port Panel Mount Model

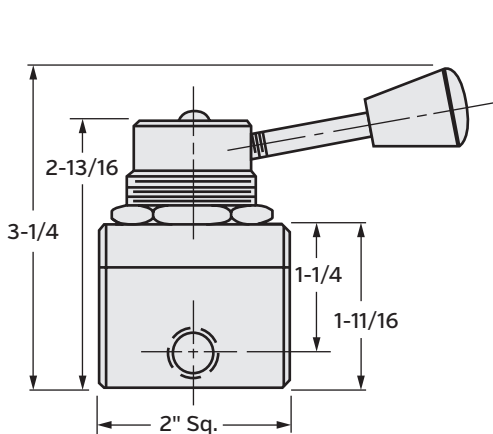

Manifold Mount Model

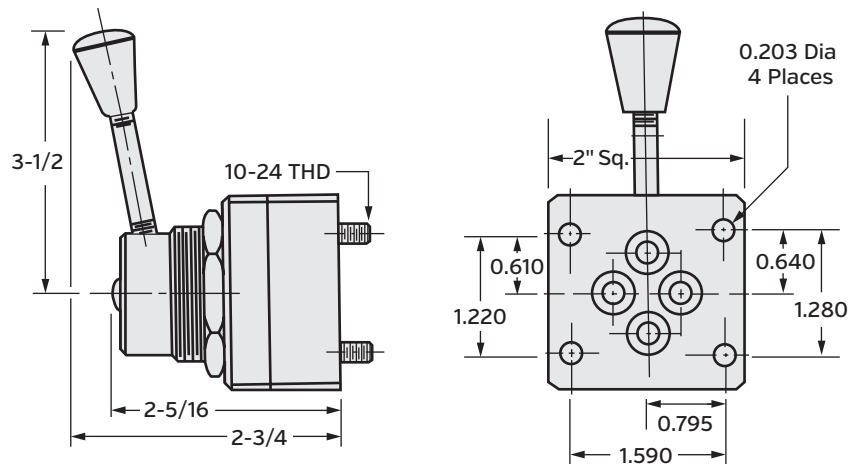



FCV Series Valves

Model: FCV-01

Valve provides for repeatable oil flow control. The internal design allows for flow in one direction and free flow in the opposite direction.

Application:

Use the FCV Series flow control valves to protect your components from damage due to high flow rates.

- Provide repeatable oil flow control.
- Internal design allows for flow in one direction and free flow in the opposite direction.
- Adjustment knob can be locked.

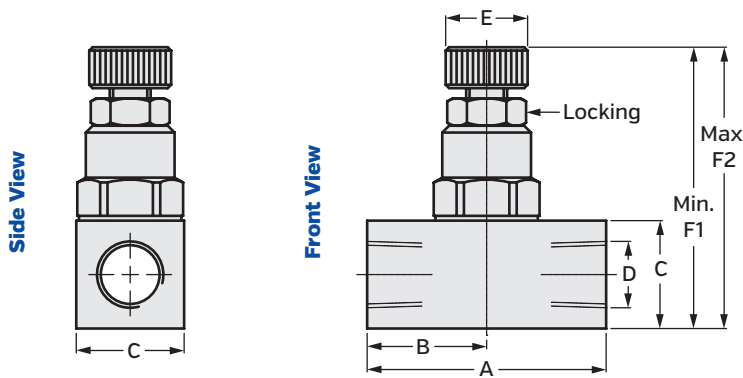

FCV-01	
A	1.38 [35]
B	0.75 [19]
C	0.62 [15.9]
D	PT 1/8
ØE	0.47 [12]
F1	1.61 [41]
F2	1.75 [44.5]
Weight (lbs/kg)	0.18 [0.08]

2404-06-06 Adapter



- 3/8" Male NPT to #6 Male JIC [6MJ] - 6MP)
- For use on KHP3 pumps bought BEFORE October 2017 with a Female NPT Swivel on the high pressure outlet.
- Adapter converts pre October 2017 pump outlet from 3/8" Female NPT to #6 Male JIC to make them compatible with current hoses options.

Kurt Part #	Optional Hydraulic Hoses (sold separately)
KTH3	36" Kurt Tuff Hydraulic Hose W/Fittings, #6 Male Pipe, #4 Female JIC
KTH6	72" Kurt Tuff Hydraulic Hose W/Fittings, #6 Male Pipe, #4 Female JIC
KTH12	144" Kurt Tuff Hydraulic Hose W/Fittings, #6 Male Pipe, #4 Female JIC



For use on KHP3 pumps bought BEFORE October 2017 with a Female NPT Swivel on the high pressure outlet.

Kurt Part #	Description
KHA040364 - Hose Assembly	1/4' x 3' LG 6FJX - 4FJX
KHA040664 - Hose Assembly	1/4' x 6' LG 6FJX - 4FJX
KHA041264 - Hose Assembly	1/4' x 12' LG 6FJX - 4FJX

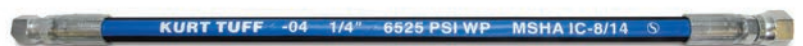

Vise locating with Bolt-on Keys vs Sine Keys

Bolt-on keys are a traditional way to locate vises to mills and beds which have t-slots. But today's machine shops also utilize grid plates with pre-machined hole patterns or mount vises to other style sub-plates and fixture plates for many applications. This usually requires machining mounting holes into the bottom of most vises for these applications.

New Kurt vise models have better and more flexible locating features than previous vise designs. They can still be located to t-slots using sine keys, plus they have additional mounting hole patterns to fit 2" x 2", 40mm x 40mm, 50mm x 50mm grid patterns.

Kurt vise models using the new Sine Key feature include: DX4 & 6 series, 3400, 3600 & 3800 series, HD690 series, XL6 series, HDL 4 & 6 series and HDM6 series.

Traditional vise keyways for t-slot mounting.

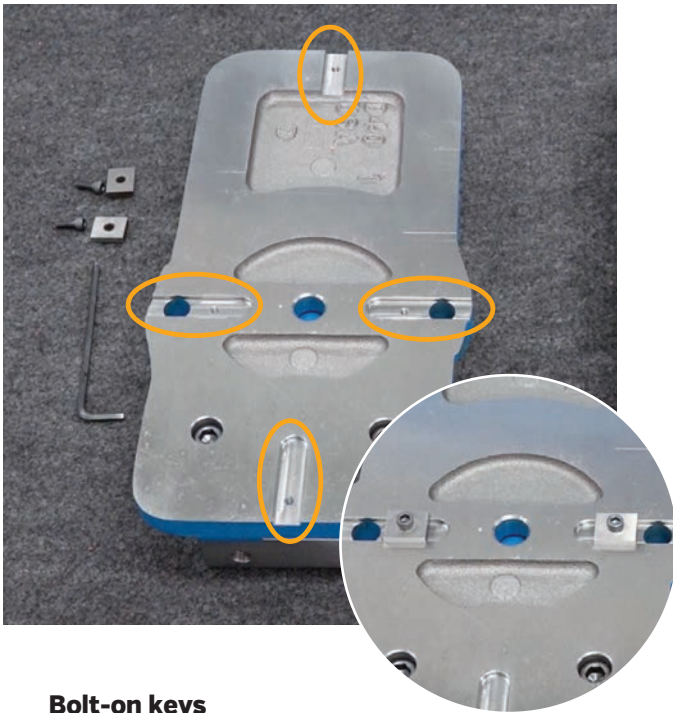

Bolt-on keys

1. Requires mounting with SHCS screws
2. Slow mounting: uses hex wrench for tightening
3. Slow unmounting: using hex wrench
4. No additional mounting features

Dowel holes for installing sine keys for t-slot mounting or for alternate mounting options listed below #5.



Sine keys

1. No screws required - o-ring holds securely
2. Fast mounting: inserts easily into dowel hole
3. Fast unmounting: sine keys quickly release
4. Precision mounting to grid plates: 2" x 2", 40mm x 40mm, 50mm x 50mm
5. Alternate mounting made easy. Mount to sub-plates fixture plates and tombstones. No need to drill additional holes in vise base.



IMPROVED MOUNTING OPTIONS
Scan QR code or visit
www.kurtworkholding.com/mounting

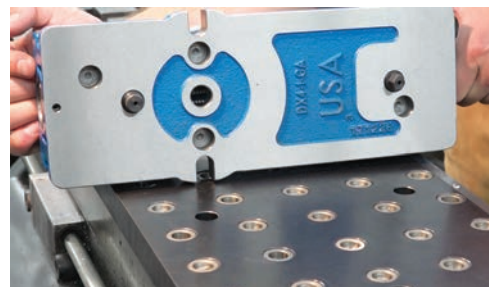

Automatic Drawbar



Mechanical Drawbar



PowerLock Drawbar

Available for most manual & CNC mills with standard R-8 collets or 30 or 40 taper tool holders. Automate your present "Knee-Type" milling machines by installing a Kurt PowerLock Drawbar. PowerLock Drawbars reduce tool change time and allow more cutting time in the cycle. This eliminates waste. The whole process using the Kurt automatic or mechanical PowerLock Drawbar cuts the tool change time to one-fourth the time required to change tools manually with wrenches. An added benefit is consistent torque on the drawbar rod. When you multiply the time savings for every tool change on all of your mills, it can really add up.

Features:

- Easy installation - operator can install with no special tools (instructions provided).
- Reduces operator fatigue - improves productivity and safety.
- Eliminates drawbar tapping to free tool in collet - reduces operator abuse.
- Convenient control - eliminates operator stretching to reach the drawbar.
- Assures uniform collet tightening - prevents under tightening and tool slip or over tightening and drawbar breakage.
- Operates on shop air supply - filter/lubricator, regulator and gauge included with most units. Provides clean oiled air to ensure long life.
- Safety interlock on automatic models prevents accidental engagement.
- Used with present tooling - operates R-8, #30 & #40 taper tool holders. Additional special tool holders not needed.
- Machine your own Drawbar Kits. Available for R-8 collets, #30 or #40 taper tool holders.
- Patented

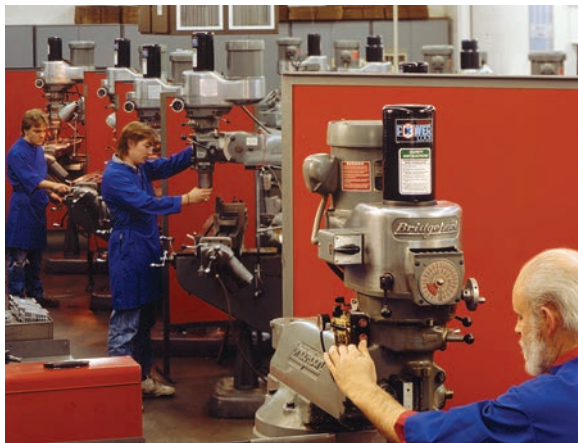

PowerLock Drawbar is available for these popular mills:

Acer	Lagun
Acramill	Mighty
Alliant	Millport
Bridgeport	Royal
Chevalier	Seiki
Clausing/Kondia	Sharp
Comet	Shizouka
DoAll	South Bend
Ex-Cell-O	Southwestern
Hurco	Supermax
Jet	Tri-Onics
Kent	Webb
Kondia	Willis

For manufacturers not listed, contact factory.

*Note: All machines that have Erickson Quick Change Spindle, and are converted to a Power Drawbar will have sharp threads and drive keys exposed near the spindle nose. We recommend the installation of a 194-00-SA Erickson Spindle Nose Guard.



You can also view a tutorial video on this process at the Kurt Workholding YouTube Channel.

www.youtube.com/kurtworkholding

Custom Engineered Workholding

Kurt brings more than five decades of experience in providing solutions to CNC machine workholding problems and a deep understanding of how workholding integrates into today's productivity and quality driven manufacturing process.

At Kurt, we provide the complete spectrum of workholding solutions with the same dedication that has produced the most successful vises for over 40 years. Our custom engineered workholding engineers have built an industry leading reputation assisting automotive, aerospace and other metalworking intensive industries to improve quality and reduce cycle times.

1 Year Iron Clad Warranty

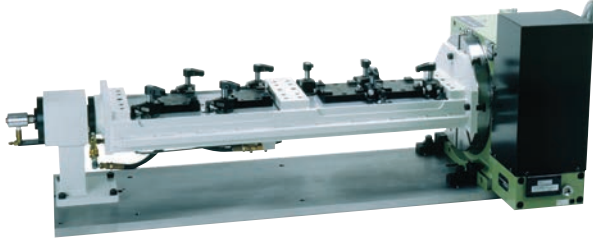

Application: Medical Device

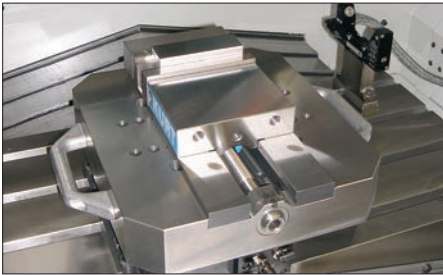

Solution: Custom pallet vise enhances VMC throughput for Device manufacturer.

Application: Commercial Industry

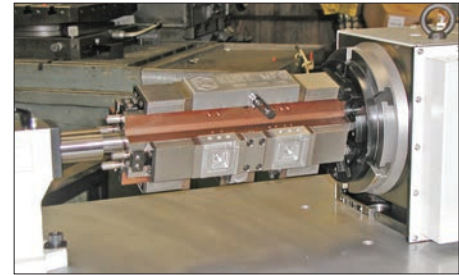

Solution: Eight station indexing trunnion fixture for high speed machining.

VMC Applications



Application: Hydraulic Industry



Solution: High density fixture clamping four parts per station.

Application: Machine Tool Industry

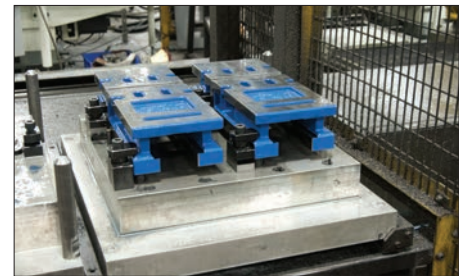

Solution: Grinding fixture increases holding power and improves accuracy.

Application: Aerospace component

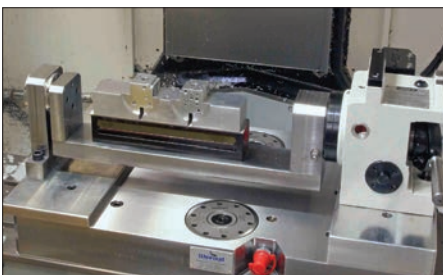

Solution: Rotary table fixtured with a zero-point docking system for repeatability.

Application: Machine Tool Industry



Solution: Second operation grinding fixture feeds productivity into FMS.

Application: Automotive Industry

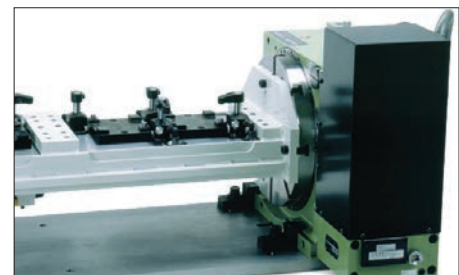

Solution: Up to three-sided machining using an indexing trunnion fixture.

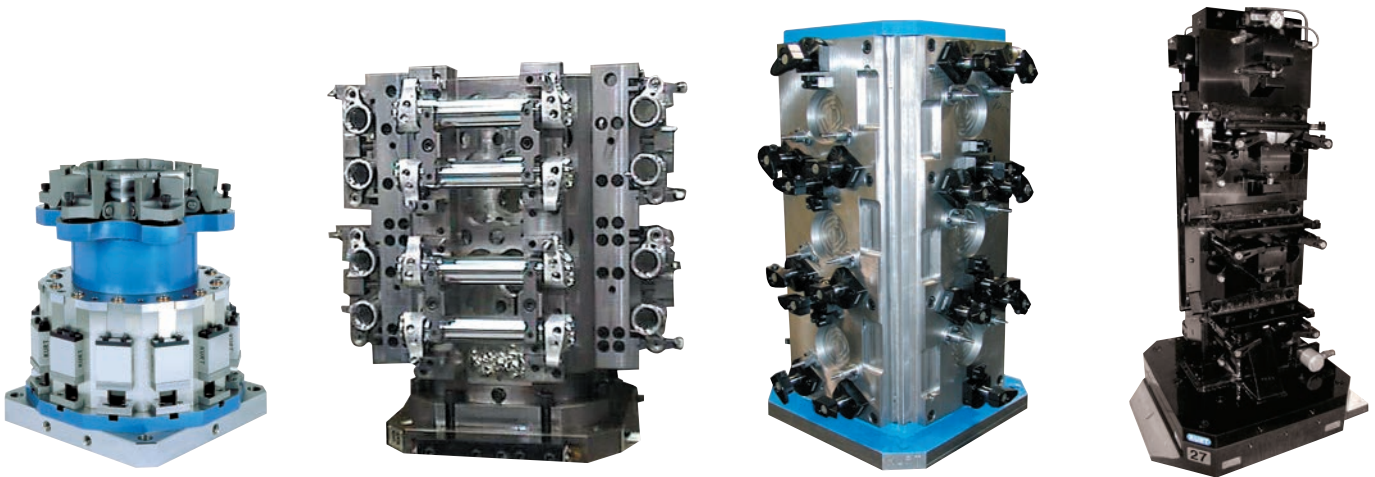

Application: Aerospace Industry



Solution: High density DoubleLock vise setup holds 18 parts for precision machining.

Application: Machine Tool Industry

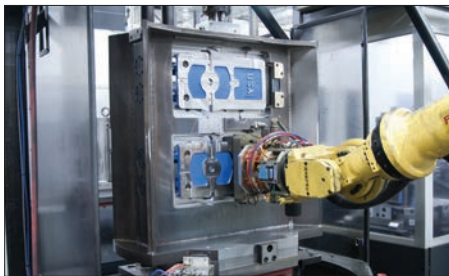

Solution: Window fixture for 2 sided machining enhances automated FMS line.

Application: Hydraulic Industry



Solution: Multiple towers with DoubleLock vises on palletized machining center for 24/7 production.

HMC Applications



Application: Hydraulic Industry

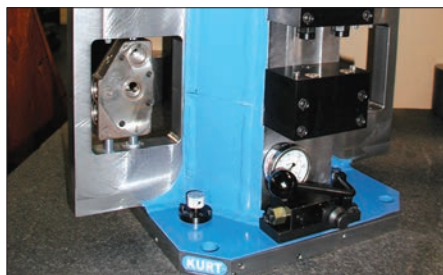

Solution: Window hydraulic (AB Load) fixture allows matching on five sides.

Application: Aerospace Industry

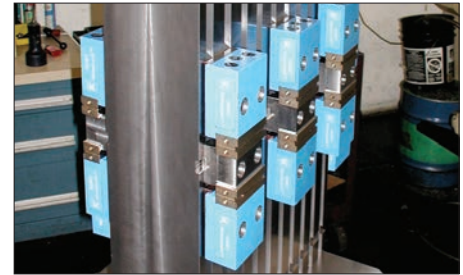

Solution: Two-sided tombstone with six MoveLock clamping stations handle wide range of part sizes.

Application: Automotive Industry



Solution: D100 movable and stationary jaws integrated onto a tower.

Application: Hydraulic Industry



Solution: Kurt serrated Double Station vise towers on palletized machining centers for 24/7 production.

Back to Back

Back to Back Models: D100, D810, HDLM6, 3600V
 Available with and without risers – consult factory for options.



36V2T400 - 3600V mounted back to back on a 400mm pallet

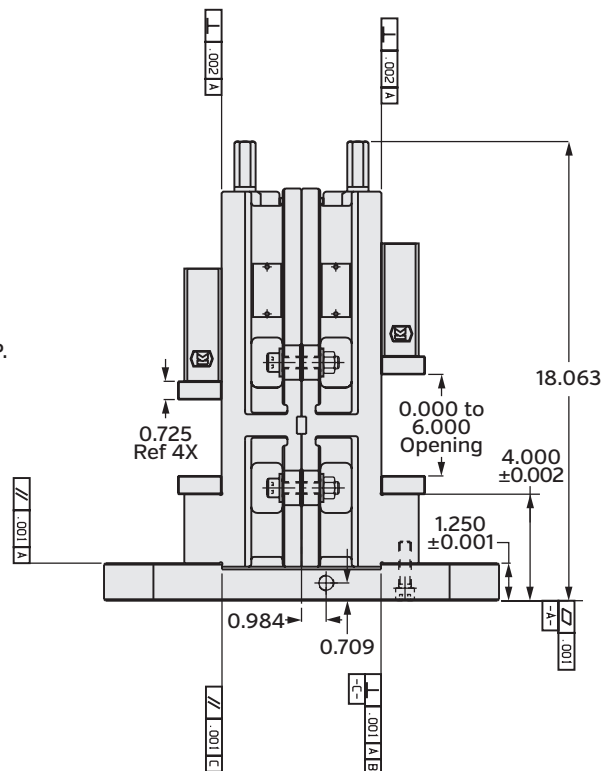
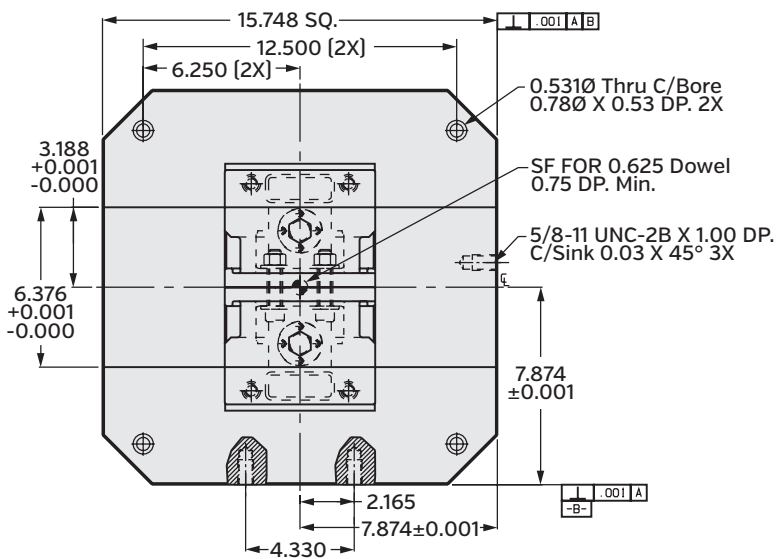

3600V Back to Back
 Available with and without riser - consult factory for options.

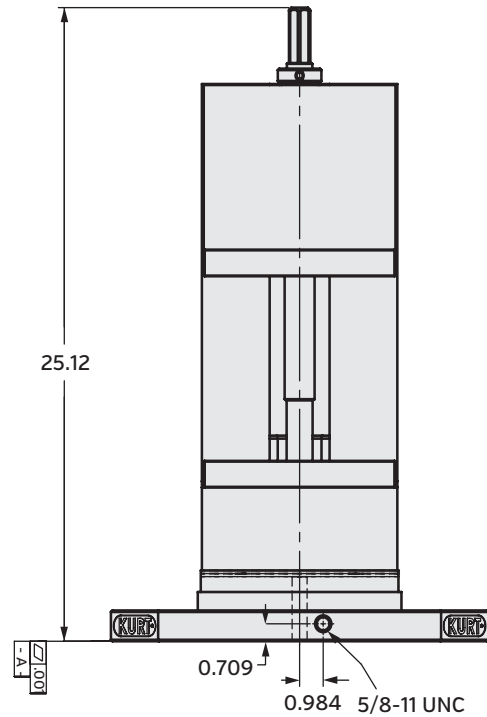
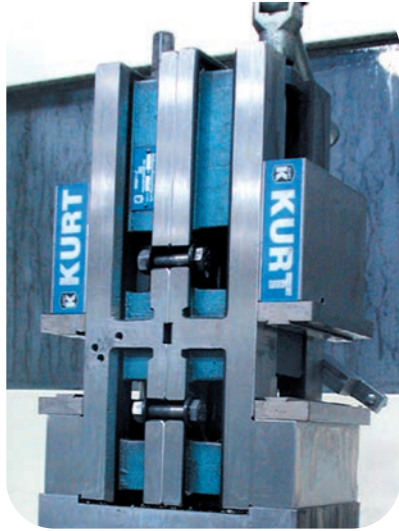

38V2T400-3800V back to back on a 400mm Base

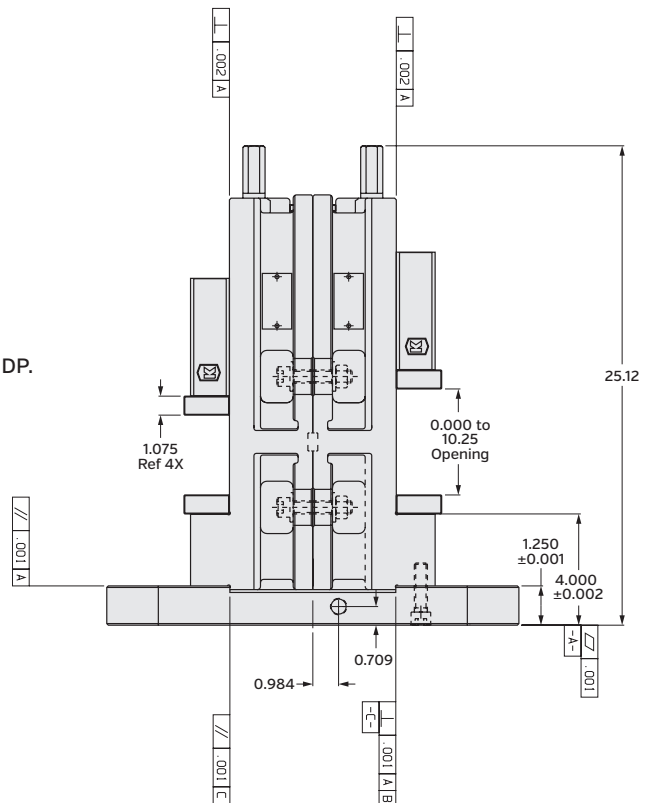
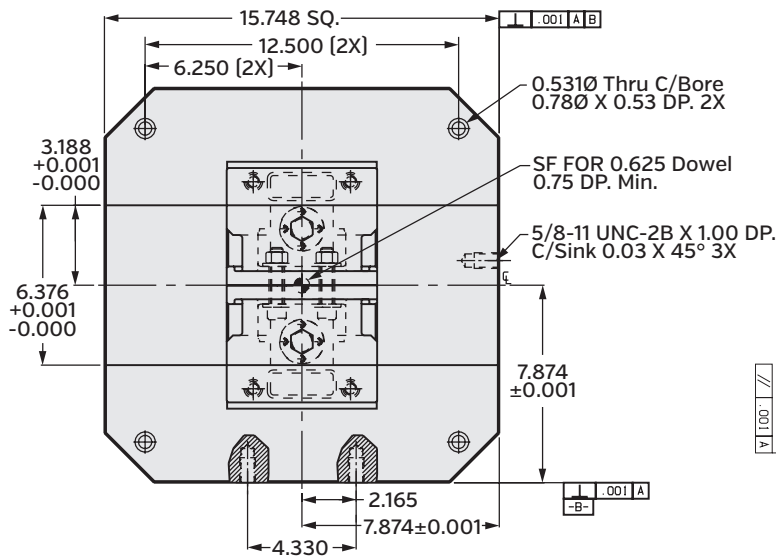

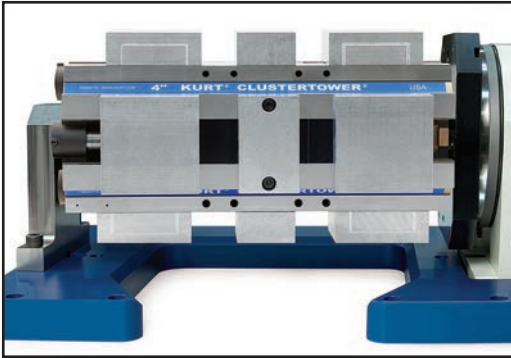

Add this tower to your indexer or have Kurt provide a turnkey solution.

Kurt Rotary Table Workholding Systems

Features:

- High density vise tower system. Hold multiple parts in eight clamping stations. Increase part volume.
- Repeatable clamping to 0.0002". Each station delivers up to 7,460 Lbs. of clamping force at 70 Ft Lbs of torque.
- Self-adjusting holding block of either front or back jaw for clamping the same or dissimilar sized parts. To further enhance fast operation, an adjustable pre-load feature reduces handle turns for opening and closing clamping stations.
- Ductile iron column insures strength, rigidity and long term accuracy.
- Jaw options available to fit your application. Select from hard jaws, machinable aluminum jaws, machinable ductile iron jaws and aluminum fixture plate.
- Jaws are indexable 180 degrees.
- Lifetime Iron Clad Warranty.
- Optional single-station convertible kit available for machinable jaws [CTHDLM4-CONVKIT] and hard jaws [CTHDLM4J-CONVKIT].

What comes with the kit:

- Four-sided column with jaw kits
 - End Support Assembly
 - Indexer Locator
 - T-Nuts
 - Face Plate
 - Locating Pin
 - Screws
- *Sub-plates not included. Can be quoted separately.

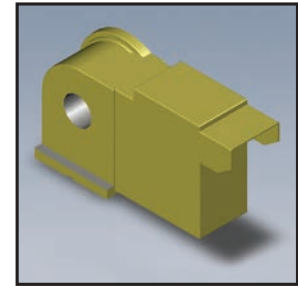
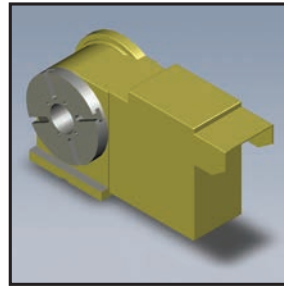
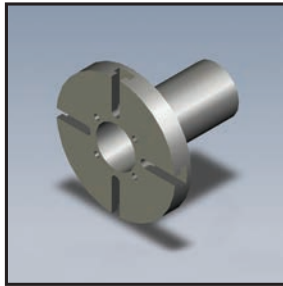
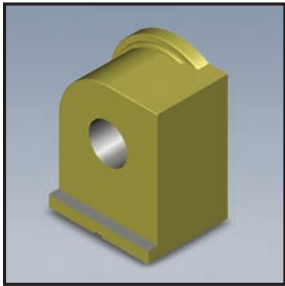

Kits are available for the following models:

Centroid (Golden Sun)	Haas	Hardinge	Nikken		SMW	Troyke	Tsudakoma		Yuasa	Yukiwa
RT-150 [CNC-151R]	HRT210	GD160	CNC180	CNC302	RT-225	DL-9	RN-150 [FP]	RNCM-301	DMNC-220	JNC170 [FP]
RT-200 [CNC-201R]	HRT310	GD210	CNC180B	CNC302B	RT-275	DL-10	RN-200 [FP]	RNCM-401	DMNC-280	JNC200 [FP]
RT-250 [CNC-251R]			CNC202	CNC320		DL-12	RN-250	RB-250	DMNC-320	JNC250 [FP]
RT-320 [CNC-321R]			CNC202B	CNC321			RN-300	RB-300	DRFT-220	YNC170 [FP]
			CNC200	CNC321B			RNCV-401	RZ-160 [FP]	DRFT-280	YNC200 [FP]
			CNC250	CNC400			RNCM-251	RZ-200 [FP]	DRFT-320	YNC250 [FP]
			CNC260	CNC401						
			CNC260B	CNC401B						

Available jaw and fixture options:

- Aluminum, cast iron, steel, and fixture plate.
- See Pages 44-47



Air Vise - Air Powered Vise for Automation

- Air powered motorized clamping provides consistent preset force and can be set to stop precisely on location
- Works great in automated systems and with Robotic workpiece handling
- Helps provide consistent clamping in unattended CNC operation
- Can be equipped with most Kurt vise models
- Air motor can be positioned under or on the side of the vise
- Operates on 20-100 PSI and requires air/oil mist
- Movable jaw can move through the entire stroke of the vise
- Air motor advantages include clean and easy pneumatic circuit hookup



640XL Air Motor Vise

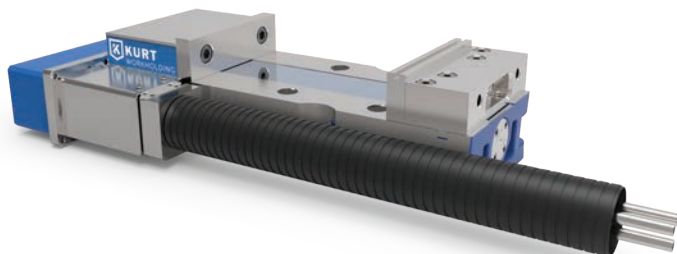

DX6 Air Motor Vise

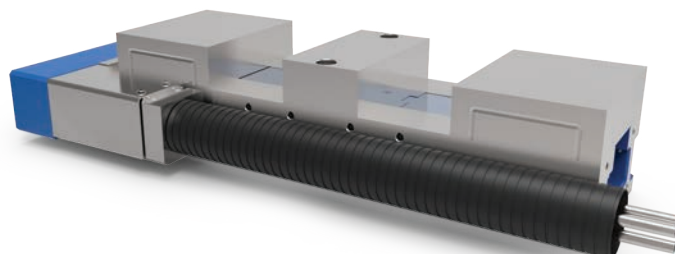

HDLM6C Air Motor Vise

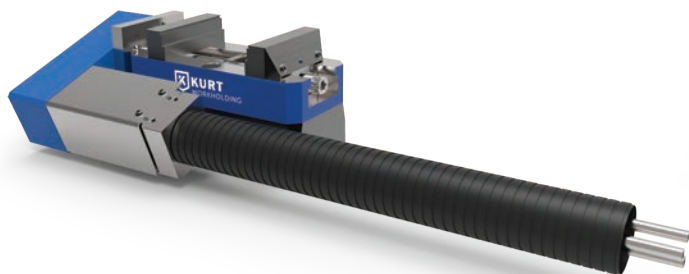

PF460 Air Motor Vise

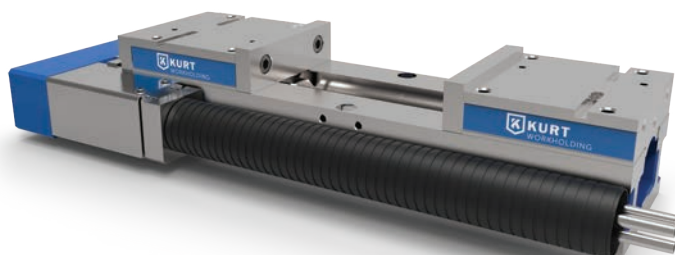

SCD640 Air Motor Vise

Servo Vise - For Automation

- Variable speed servo and position programable
- Servo powered vise with Allen Bradley 570 watt Servo Motor
- Capable of handling loads up to 80 ft-lbs torque (Max torque with most Kurt 6 inch vises)
- Encoder
- Gear Drive and Gear Box Assembly Included
- Ethernet Cable [8 Conductors] Included
- Optional Ethernet/IP Servo Drive and cable sold separately

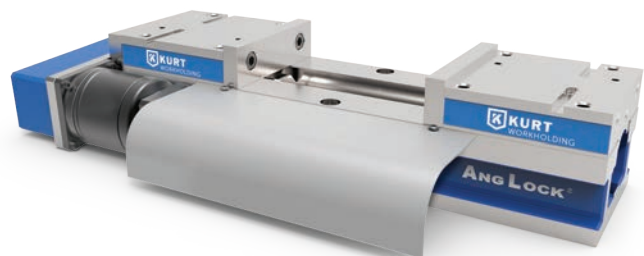

SCD640 Servo Motor Vise

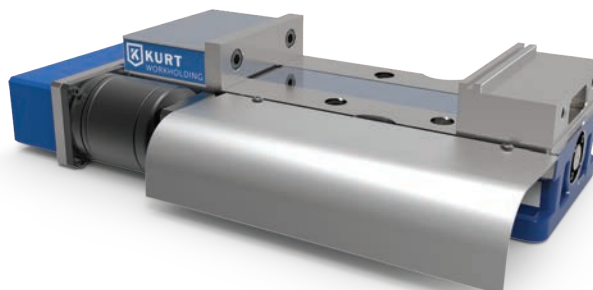

DX6 Servo Motor Vise

KURTSmart™ PROBE

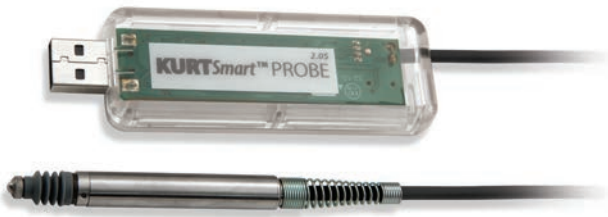

The KURTSmart™ PROBE is a standalone device that will provide a measurement result without being connected to any kind of computer station. The probe is completely linear over the entire stroke length. With a set of five small LED's on each side of the probe, the device can be programmed to visually show an operator if a part is good (green), trending bad (yellow) or bad (red). Each KURTSmart™ PROBE also has a single output port that can be utilized.

Specifications:

- 14 Bit Precision
 - 2.0mm probe travel, approximately 0.125 micron resolution
- Range from 0.5mm to 10.0mm
- Pre-calibrated - All devices measure identically over the full stroke
- On board dynamic scans: MAX, MIN, TIR, AVG
- LED indicators have a programmable scale to fit a tolerance range
 - Visible from Top or Side, mounted on both sides
- On board I/O for stand-alone operation
 - I/O is 5-24VDC Optically Isolated
 - Input: Programmable to trigger events such as data collection, re-mastering or others
 - Output: Programmable to trigger on LED or measurement status
- Namable for consistent identification by the software
- USB to COM port interface
 - Compatible with any software that can import RS-232 data
- Compatible with standard USB hubs allowing multiple probes per system

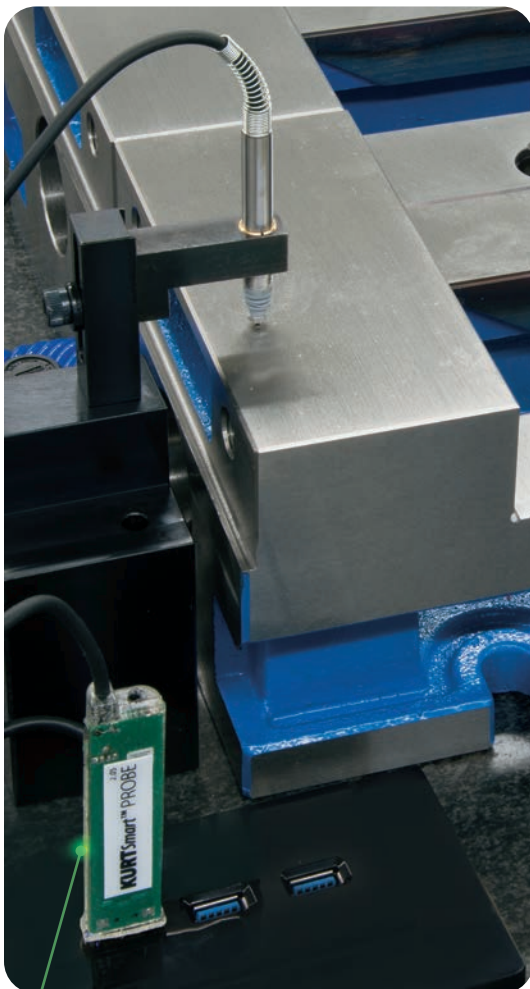

LED indicates whether a part is good (green), trending bad (yellow), or bad (red).



Kurt probes are available in many lengths and spring extended and pneumatically extended versions.

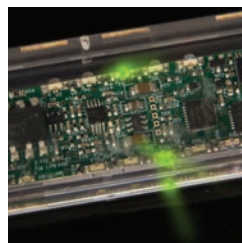

LED indicates: good (green)

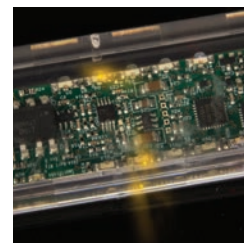

LED indicates: trending bad (yellow)

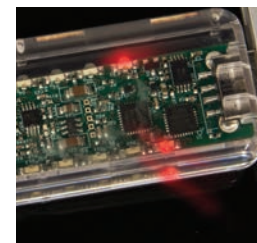

LED indicates: bad (red).

Gaging Products & Automation

Designed, built and tested by a manufacturer for manufacturing companies.

As manufacturing requirements continue to change, demanding higher precision, accuracy and output, gaging requirements have also changed. The need for precise, reliable gages, built to service the increasing demands of manufacturing has become a driving force for gage builders. Kurt has been responding to these demands since the late 80's by providing superior measurement solutions that include gaging hardware, software and electronics for virtually any measurement requirement.

Kurt's simple yet robust designs provide measurement resolutions in the millionths, with gage R&R capabilities of 10% or less in most cases. Kurt's Modular Gaging systems can measure your most challenging features on OD's, ID's and lengths, including GD&T callouts such as position and form, in systems for manually loaded post process fixtures to in-line fully automatic machines using contact or non-contact measurement technology.

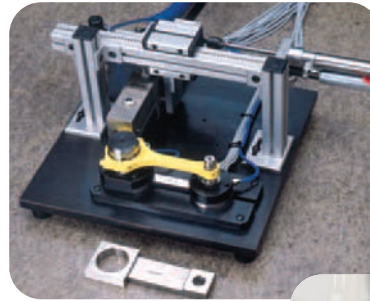

Bench-top, post-process gaging fixtures configured around any part

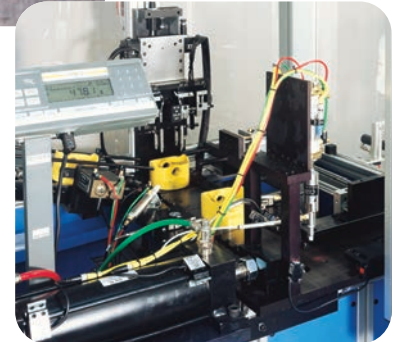

In-Line Fully Automated Gage Fixture

KurtPremium Data Collection Software

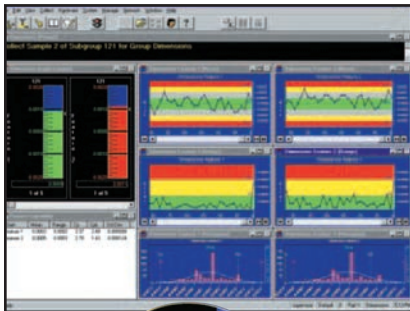

KurtICS Industrial Computers



Kurt USB Gaging Interfaces



KURT Smart™ DISPLAY and KURT Smart™ PROBE



KURT Automation & Gaging Solutions

The Kurt Integrated Technology (KurtKIT) provides automation integration of gaging, custom workholding and robotics. In addition to custom gaging and workholding, Kurt Engineered Systems now provides turn-key automatic cell integration robotic solutions using FANUC Robotic systems. As a stand alone robotics system or an integrated solution, the Kurt Integrated Technology systems provide you with a complete one-stop source for your manufacturing needs.

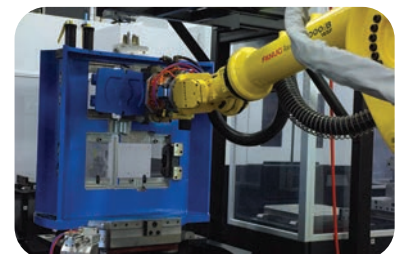
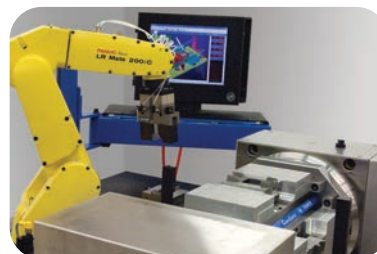

Repair Kits For Vises

Single Station Vises	*D40-KIT	*D50-KIT	D60-KIT	*D675-KIT	*D688-KIT	DX6-KIT	D80-KIT	*D810-KIT	D100-KIT
Cap, Plastic	D40-12A	D50-12A	D60-12A				D80-12A		D100-12A
Drive Type Grease Fitting				3300-C				3300-C	
Internal Brush Seal				D675-211	D688-211 [x2]	D688-211 [x2]		PT800-211 [x2]	
O-Ring	D40-68	D50-68		D675-68	D675-68	3600V-99 3600V-128		D810-68	
Plug, Grease Fitting				D675-292				D675-292	
Segment	D40-9	D50-9	D60-9	D60-9	D60-9		D80-9	D80-9	D100-9
Grease Fitting				3300-C					
Spiral Retaining Ring	D40-217A	D50-217A	D675-217A	D675-217A	D675-217A	3600V-147 [x2]		D810-217	
Thrust Bearing	D40-41	D50-41	D60-41	D60-41	D60-41	D80-41	D80-41	D80-41	D100-41
Thrust Bearing Washer	D40-42 [x3]	D50-42 [x3]	D60-42 [x3]	D60-42 [x3]	D60-42 [x3]	3600V-42 [x2]	D80-42 [x2]	D80-42 [x3]	D100-42 [x3]
Wave Spring						DX6-169 [x2]			

*= Same as Metric Vise

Single Station Vises	*3600V-KIT	3600H-KIT	HD690-KIT	PT400A-KIT	PT800A-KIT	PTH400A-KIT	PTH800A-KIT
Back Up Ring		PTH600-188 360HU-187				PTH400-188 PTH400-187	
Springs			HD6-197				
Guides			HDM6-142				
Screws			00-0251				
Cap, Plastic							
Internal Brush Seal	3600V-211 [x2]	3600V-211 [x2]	D688-211 [x2]	PT400-211 [x2]	PT800-211 [x2]	PT400-211 [x2]	PT800-211 [x2]
O-Ring and/or Backer Rings	3600V-99 3600V-128	3600V-99 3600V-128 360HU-98 PTH600-96	3600V-99 3600V-128 MT6-96	PT400-99	PT800-99A	PT400-99 PTH400-198 PTH400-197 PT400-97	PT800-99A PT800-97
Polypak Piston Seal							PTH800-198A PTH800-96A
Segment	D60-9	D60-9		D40-9	D80-9	D40-9	D80-9
Spiral Retaining Ring	3600V-147 [x2]	3600V-147 [x2] 360HU-231					
Thrust Bearing	D80-41	D80-41	D80-41	PT400-41	PT800-41	PT400-41	PT800-41
Thrust Bearing Washer	3600V-42 [x2]	3600V-42 [x2]	3600V-42 [x2]	PT400-42 [x2]	PT800-42 [x3]	PTH400-42	D80-42 [x2]
Thrust Washer							PTH800-42 [x2]

*= Same as Metric Vise



HDHL Nut & Screw Assembly



HDL Nut & Screw Assembly

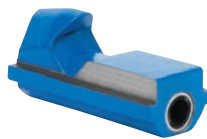

Vise Nut, D-Series



Vise Screw, D-Series



Vise Screw, HD-Series



Vise Repair Kit



D675 Repair Kit



Bearing Assembly



Thrust Bearing Washer



O-Ring



D675-292 Plug, Grease Fitting



3300-C Drive Type Grease Fitting



Plastic Cap



Spiral Retaining Ring



Internal Brush Seal



Segment



Movable Jaw w/jaw Plate



Rear Stationary Jaw



Clutch

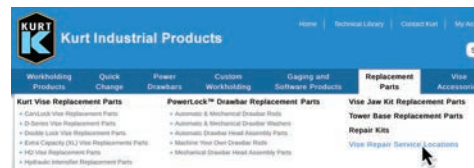

Find your local workholding service center by following the "Vise Repair Service Locations" link at www.kurtworkholding.com

Repair Kits For Vises

Double Station Vises	Serial # <-3300 DL430-KIT1	Serial # 3301- > DL430-KIT2	Serial # 1000-3734 *DL640-KIT1	Serial # 3735-4999 *DL640-KIT2	Serial # 5001- > *DL640-KIT3	HDL4-KIT1	HDHL4-KIT1
Back Up Ring							HDHLM4-187 HDHLM4-188
Friction Clamp	DL430-225A	DL430-225A-P					
O-Ring	DL430-128 DL430-68	DL430-127 DL430-128 DL430-129 DL430-68	DL640-128 DL640-68	DL640-128 DL640-68	DL640-128 DL640-68 DL640-129	DL430-127 DL430-128 DL430-129 DL430-68	360AU-99B 360OV-99 MT4-96 HDHLM4-68 HDHLM4-96
Pin, Dowel	04-0031	04-0030	04-0031	04-0031	04-0030	04-0030	
Pin, Roll	04-4138		04-4144	04-4144			
Protective Plug							HDLM4-191
Retaining Ring	DL430-217 DL430-217 DL430-231	DL430-147A DL430-217 DL430-231	DL640-147	DL640-147A DL640-147 DL640-217 DL640-231	DL640-217 DL640-231	DL430-147A DL430-217 DL430-231	
Seal, U-Cup			DLU6J-146				
Segment	D40-9	D40-9					
Spring		DL430-197 [x4]					
Spring Clutch	DL600-215A	DL640-215A [3]	DL600-215A [4]	DL600-215A [4]	DL640-215 [3]	DL640-215	KDLM4-169
Spring, Pre-Load	DL430-311A	DL430-311A	DL640-311A	DL640-311A	DL640-311A	HDLM4-311	HDHLM4-311
Thrust Bearing	D40-41	D40-41	D60-41	D60-41	D60-41	D40-41	
Thrust Bearing Washer	DL400-42A [x2]	DL400-42A [x3]	D60-42 [2]	D60-42 [2]	D60-42 [3]	DL400-42A	
Truarc Ext. Snap Ring					DL640-147B		
U-Cup Seal			DL640-180 [2]				
Wiper Ring Seal	DL430-331 [x2] DL430-97	DL430-97		DL640-331 [2] DL640-97	DL430-331 DL640-97	DL430-97	

*= Same as English/Metric Vise

Replacement Parts	HD6-KIT1	HDH6-KIT1	*HDLM6-KIT1	HDHLM6-KIT1	Hydraulic Intensifiers	
Back Up Ring		HDH6-187 HDH6-188		HDH6-187 HDH6-188	APD50-112-KIT	APD60-112-KIT
Friction Clamp					APD50-119 APD50-127 APD50-128 APD50-129 APD50-130 APD50-131	APD60-127 APD60-128 APD60-129 APD60-130 APD60-131
O-Ring	360OV-99 HD6-68 HD6-96	MLH35-173A PM43-96 HDH6-96 HDH6-68	DL640-128 DL640-68 DL640-129	HDH6-96 DLU4-96 HDH6-68		
Pin, Dowel			04-0030			
Plug, Nylon				HDHLM6-168		
Protective Plug				360OV-191		
Retaining Ring	DL640-217		DL640-217 DL640-231	DL430-217 DL430-231		
Spring Clutch/Compression			DL600-215 [x3]	HDHLM6-169		
Spring, Pre-Load			DL640-311A	HDHLM6-311A		
Thrust Bearing	D60-41		D60-41			
Thrust Bearing Washer	D60-42 [x2]		D60-42 [x2]			
Truarc Ext. Snap Ring	HD6-147		DL640-147B			
Wiper Ring Seal	DL640-97		DL430-331 DL640-97	DL430-97 DL430-331		

Power Drawbar Parts



500-00 Drawbar Assembly Cover



101-02 Powerhead Assembly



Mechanical Power Drawbar Assembly



212-1000 Drawbar Wrench



102-01A Valve Assembly w/FRL [312-06], Switch [102-04A]



Drawbar



202-03-SA Actuator Block Assembly



400-10 Universal Base



208-00 Drawbar Socket

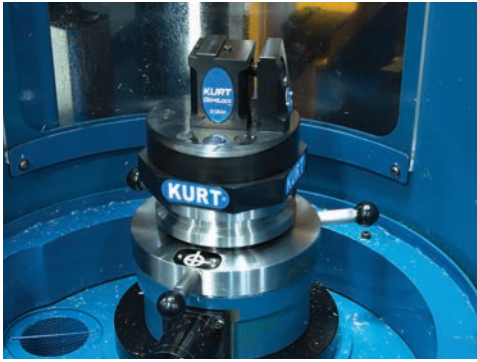

DTR DoveLock 5 axis vise mounted on a Kurt Pallet



XL vises mounted back-to-back

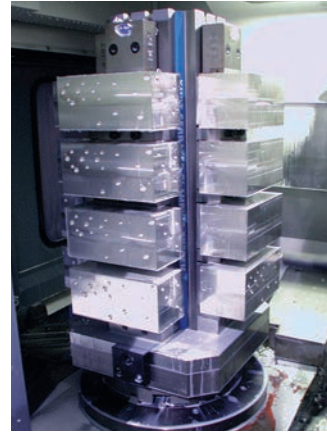

SeraLock Towers for high density



DoveLock jaws used for glass machining



MaxLock 5 axis vise mounted in a Kurt vise used as a receiver.

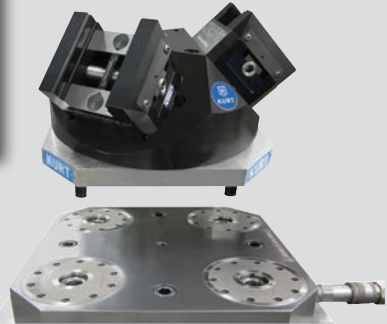

5 axis vises on Pyramid platform using zero-point system.

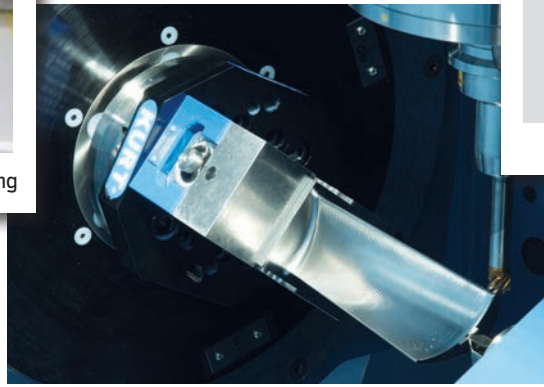

MaxLock 5 axis vise used for turbine blade machining

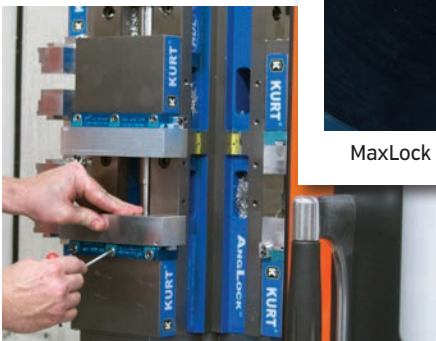

DoveLock jaws provide 1 minute changeover

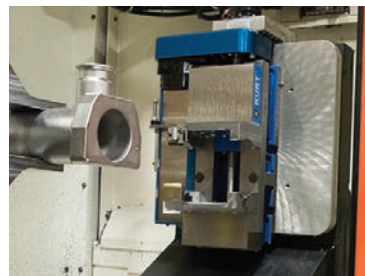

Air powered vise used in a robotic cell



Cluster Tower using fixture plate & Soft jaws

Kurt® Manufacturing Industrial Products Division

9445 E. River Road NW, Minneapolis, MN 55433

Phone 763.574.8309 Toll Free Phone US & Canada 1.877.226.7823

Fax 763.574.8313 Toll Free Fax US Only 1.877.226.7828

email workholding@kurt.com www.kurtworkholding.com

AngLock, ArmLock, CarvLock, Cluster Tower, CrossOver, D688, DL430, DX6, DoubleLock, Groove Lock, InnerLock, Kurt, SeraLock, and VersatileLock are registered trademarks of Kurt Manufacturing.

DoveLock, DX4, Kurt Smart, MaxLock, SideWinder, and ToolBlox are trademarks of Kurt Manufacturing.

Printed in USA © Copyright. All rights reserved
LIT.VCAT.12.20