



**KURT** WORKHOLDING

# HDHL6 Manual Hydraulic Assembly

Operating Instruction Manual  
HDHL6 (English) & HDHLM6 (Metric)



ENGLISH

# TABLE OF CONTENTS

Introduction .....	3
Setup Instructions .....	4
Vise Installation Instructions.....	5
Hydraulic Setup .....	6-8
Operating Instructions.....	9-17
HDHL6 Parts List.....	18
HDHL6 Mechanical Drawing .....	19
Maintenance Schedule .....	20-21
Troubleshooting Tips .....	22
Maintenance Log/Notes .....	23
Warranty .....	24

## WISE DATA

Use this to fill out information about your vise for quick reference.

Purchase Date: \_\_\_\_\_ - \_\_\_\_\_ - \_\_\_\_\_

Purchase Order: \_\_\_\_\_

Purchased From: \_\_\_\_\_

Delivery Date: \_\_\_\_\_

Serial No.: \_\_\_\_\_

**NOTE: MAKE SURE TO REGISTER YOUR WARRANTY ONLINE AT  
KURTWORKHOLDING.COM**

# INTRODUCTION

Thank you for purchasing a Kurt HDHL6 vise. You have just purchased one of the best machine vises in the industry. The outstanding accuracy of this product is second to none. Backed by a lifetime warranty against workmanship and material defects, this product is built to last when used and maintained properly.

The original Kurt Anglock vises are designed for precision clamping on basic machine tools such as knee-type mills, and machining centers. They can be used for, but are not limited to, operations like precision boring, drilling, tapping, & finishing.

The patented Anglock design allows the movable jaw to advance in such a way that each pound of force forward induces a ½ pound of force downward which minimizes the jaw lift and increases accuracy. This, combined with the needle bearings, increases jaw clamping pressure. Other features include: 80,000 psi ductile iron body, hardened vise bed & jaw plates, and a semi-hard steel screw.

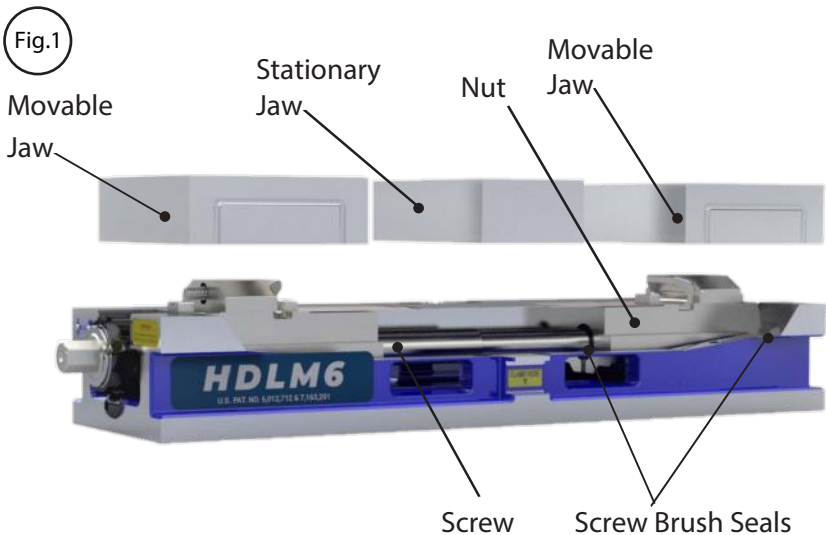

# SET-UP INSTRUCTIONS

Now that you have your new Kurt Vise, it's time to set-up and begin using it. You will see that your new vise comes with a Kurt swivel handle. The handle is specifically designed to provide maximum torque to your vise (clamping force provided below). Your vise should be mounted to a clean, flat surface. The surface and the vise must be free of any chips, dirt, or debris of any kind. The mounting surface can be honed if necessary. Clean the bottom of the vise with solvent or another cleaner if needed.

To minimize vise bed deflection, clamp your Kurt vise to your machine table, pallet, or sub-plate using the built-in clamping slots or through the body holes provided.

Additional clamping can be used, but may not be necessary. Please be sure to exercise good judgment when securing your vise to the mounting surface. Be sure your vise is secured and will not move when applying the machine pressure.

## Manual

Torque Ft.-Lbs.	Force in Lbs.
10	1540
20	2500
30	3350
40	4300
50	5750
60	6850
70	7450

## Hydraulic

Hydraulic PSI	Force in Lbs.
500	850
1000	1600
1500	2300
2000	3100
2500	3950
3000	4750
3500	5450
4000	6350
4500	7100

# Vise Installation Instructions



## CAUTION:

Do not attempt to lift the vise by attaching to any of the jaws or injury may result. Always attach lifting device to the vise base frame.

1. Position vise on your machine table, pallet or tombstone using the .625 or 16 MM locating holes found on the bottom of the vise. We recommend using the holes that are the farthest apart for better accuracy.
2. Bolt in place using strap clamps placed on the clamping ledge as indicated by “Clamp Here” sticker or by bolting directly through the vise body. When bolting through the body, the stationary jaw must be removed to gain access to those holes. The outboard holes have plugs to keep debris out and must be removed if you wish to use those holes as well. Replace plugs after bolts are secured.

**NOTE:** Some of the clamp holes are at inch locations and some are at metric. For exact hole locations, go to pages 16-17 in this manual.

3. After vise is mounted in place, add the vise jaws to the base assembly. See jaw installation instructions that came with the jaw kit. If a hard jaw kit “J style” was installed, tram the stationary jaw for straightness prior to using. If it exceeds .0006” in six inches, remove stationary jaw and disassemble the 10mm bolt, the tapered top clamp and .750 dia. split sleeve and clean with solvent and a clean cloth. Do Not apply grease or oil to these components. Re-assemble and retest. This should not be necessary when using the carvable type unless a high degree of accuracy is required and you are not re-cutting the jaw contour.

# HYDRAULIC SET-UP

The HDHL6 Series Hydraulic vises can be paired with one of Kurt's Hydraulic pumps. You can find all our pump solutions at [kurtworkholding.com](http://kurtworkholding.com)

Here are instructions for plumbing the HDHL6 vise with the KHP3 air over hydraulic pump:

1. Remove plastic caps from pressure and release ports on Hydraulic pump. Install fittings to the input and output ports (See Fig.4).
2. Remove plastic caps from pressure and release ports on hand or foot valve. Install straight fitting.
3. Install a SAE 4 straight fitting into the 7/16-20 port found on one end of the vise screw (See Fig.2).
4. A filter-regulator-lubricator combination (See Fig.4) is recommended to insure clean air coming into the unit. See clamping force chart (Page 4) for air pressure required to attain desired clamping force.
5. Connect the FRL to the input air line (See Fig.4).
6. Connect the hydraulic line to the hydraulic unit on the HDHL6 vise and then to the output side of the hydraulic pump(Fig.2 & 4).
7. If using a hand or foot valve connect the 3-line color-coded air line cluster to the same color ports on the KHP3 pump and valve (Fig.3 & 4).
8. Apply air pressure (80 PSI maximum) to system. Loosen swivel fitting at vise and bleed air. Tighten fitting. Release air pressure.
9. Repeat previous step until all air is purged
10. The KHP3 hydraulic pump will come pre-filled with oil (use #13 or DTE lite if needed)
11. System is now ready for use.

Fig.2

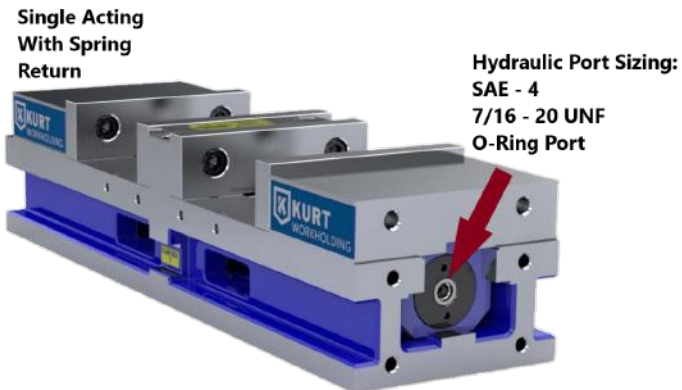

# HYDRAULIC SET-UP

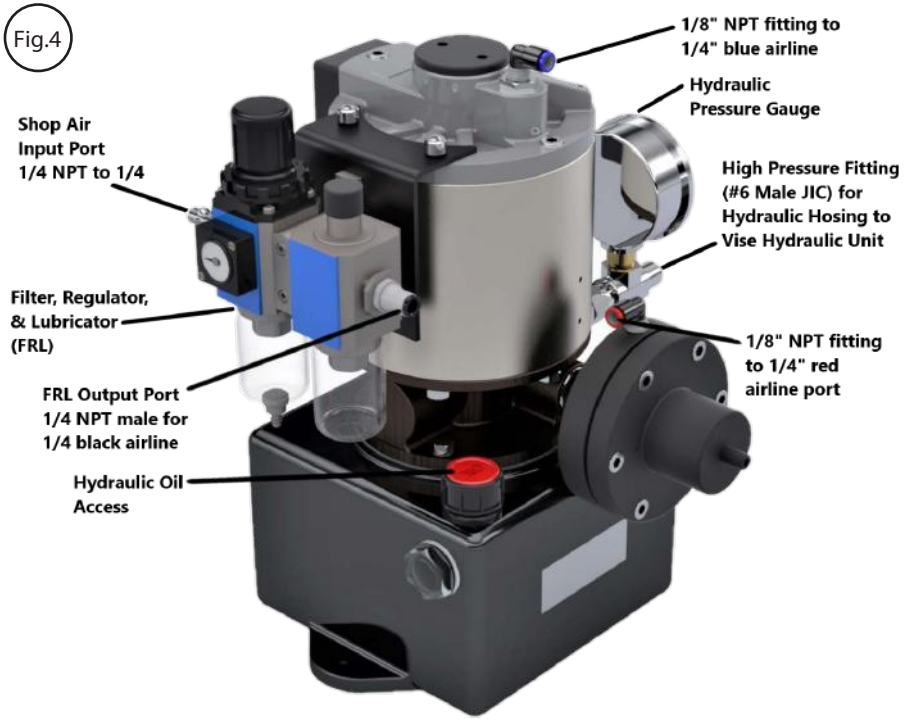

# HYDRAULIC SET-UP

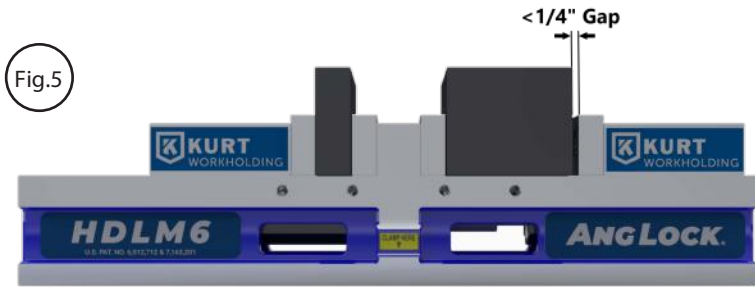

Fig.5

## Jaw Positioning:

Once all plumbing is set up, it time to position jaws for hydraulic clamping.

1. First, place parts in each jaw station making sure that the larger part is in the rear station closest to the hydraulic port.
2. Close both jaws fully by turning the handle clockwise. Both parts should be clamped at this point.
3. Back off the jaws by turning the handle counter-clockwise until the rear movable jaw is spaced within less than a 1/4 inch from the part in the rear station. The vise is now set up to be clamped hydraulically.
4. Engage the hydraulics and clamp the part hydraulically.
5. Replace the parts in both stations. The part in the front station will not have a gap between the movable jaw and the part, and will appear to still be clamped. The front part is free but is held by the preload springs in the movable jaw.
6. To remove or put a new part in this front station, push the front jaw away from the center and pull the part out or put a new part in the station.

*NOTE: To remove the preload in the jaws, purchase part number HDHM6-PRELOKIT.*



# OPERATING INSTRUCTIONS

For proper vise operation, insert the handle on to the hex end of the vise. Rotate clockwise to clamp and counterclockwise to unclamp your vise. This handle, combined with the correct amount of torque, will provide you with all the clamping force you will need to machine your parts.

**DO NOT** use any other type of pressure to open or close your vise.

**The uses of handle extensions, air impact wrenches, breaker bars, or hammer strikes are not recommended and will void the warranty if used. This will also cause damage to the thrust bearing and screw threads. If you need more clamping force you may require a larger vise. A torque wrench may be used if set within the torque limits shown in the tables on page 4.**

## **One-Sided Clamping:**

To properly clamp a part in your Kurt double-station vise, you should place the parts in the center of the jaws resting on the ways of the vise. Clamping only on one side or above the movable and stationary jaws can result in jaw lift or loss of accuracy. (See Fig. 6 on page 10)

If one-sided clamping is necessary, you **MUST** use a dummy part on the other side. When using parallels or step jaws, you must select a size that keeps the bottom of the clamped part at or below the top of the movable and stationary jaws.

Always use jaw plates for clamping. If jaw plates are not used, damage to the mounting surface of the movable and stationary jaw will occur. This will result in reduced clamping accuracy and repeatability.

Fig.6

**Sketch #2A**

Incorrect part clamping.

Vise width centerline

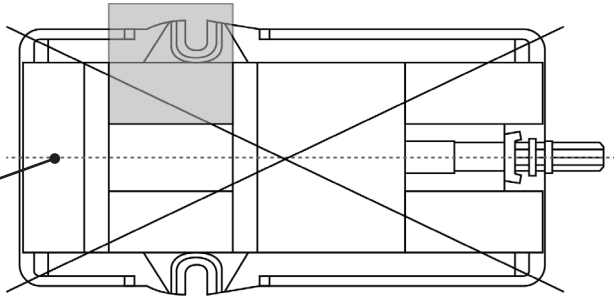

**Sketch #2B**

Correct part clamping.

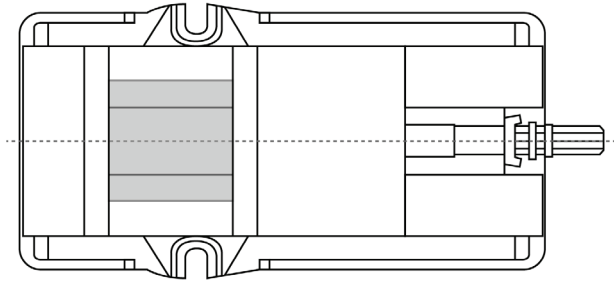

**Sketch #2C**

Correct part clamping.

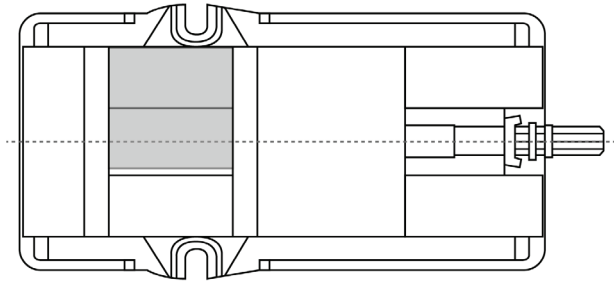

**Sketch #2D**

Correct part clamping.

Dummy spacer

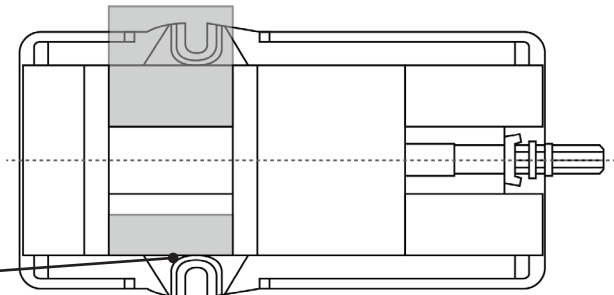

# OPERATING INSTRUCTIONS

## Clamping with Different Sized Parts:

If clamping parts of different sizes, place the smaller part in the front station and the larger part in the back station as shown in figure 7 below. This will ensure the clutch system in your vise operates properly.

Fig.7

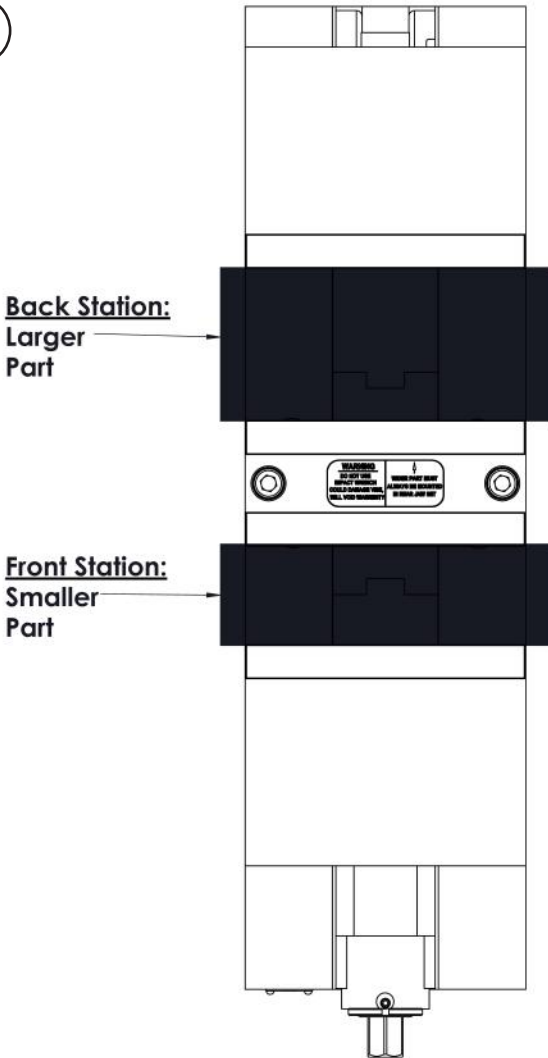

# OPERATING INSTRUCTIONS

## Clamping Using Only 1 Station:

If desiring to use only one side of the double-station vise, you must use a dummy block in the other station as shown in figure 8 below.

Fig.8

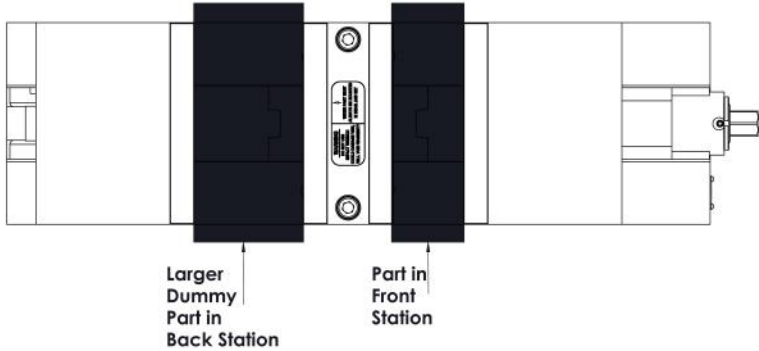

## Converting to a Single Station Vise:

If desiring to convert your double station vise to a single station, you will need to get a Kurt conversion kit through our website, [kurtworkholding.com](http://kurtworkholding.com). This kit will include a mounting plate that bolts to the rear of the vise and holds the back jaw in place. The center stationary jaw will need to be removed as well. See figure 9 below.

Fig.9



# Standard Jaw Options

## Standard J-Style Hard Jaws:

The standard J-style hard jaws are made of ductile iron and are paired with Kurt standard jaw plates. For dimensional information and jaw positioning, see figures 11-12 on pages 14-15.

## Aluminum Carvable/Machinable Jaws:

The Aluminum Carvable jaws come in two different jaw heights, 1.728" and 2.400". These jaws can be can be machined in the carvable regions of the jaw (See carvable region in figure 10) to hold curved and contoured shaped parts. **DO NOT** cut into the non-carvable region.

## Cast Carvable/Machinable Jaws:

The cast ductile iron carvable jaws have a jaw height of 1.728".

Fig.10

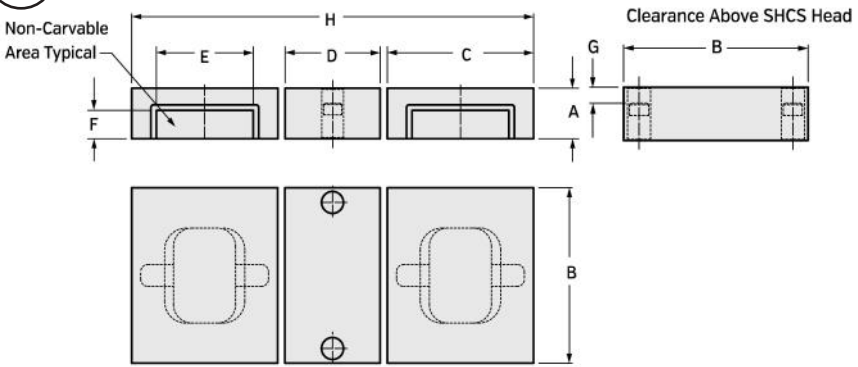

7075T6 Aluminum and Cast Iron Machinable Jaws Jaw Kit Dimensional Data for High Density 6" HD & HDL Vises						
	HD6AL Jaw Kit		HD6AL2.5 Jaw Kit		HD6C Jaw Kit	
	mm	Inch	mm	Inch	mm	Inch
A	43.891	1.728	60.960	2.400	43.891	1.728
B	152.400	6.000	152.400	6.000	152.400	6.000
C	127.000	5.000	127.000	5.000	127.000	5.000
D	82.550	3.250	82.550	3.250	82.550	3.250
E	84.120	3.312	84.120	3.312	84.120	3.312
F	24.160	0.951	24.160	0.951	24.160	0.951
G	13.260	0.522	30.330	1.190	13.260	0.522
H	349.250	13.750	349.250	13.750	349.250	13.750
Weight	3 Kgs.	7 Lbs.	9 Kgs.	19 Lbs.	15 Kgs.	33 Lbs.

# JAW POSITIONING

Fig.11

**Note:** Dimensions below are in inches unless specified.

AA	4.00
BB	8.72
CC	5.96
DD	10.69

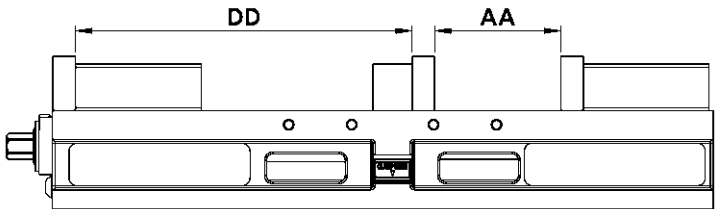
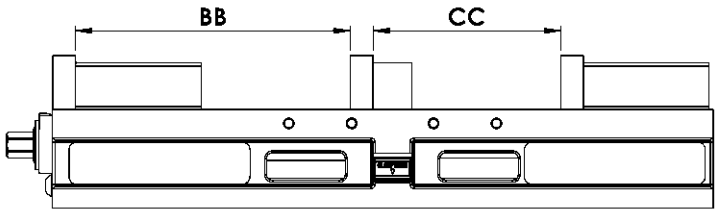
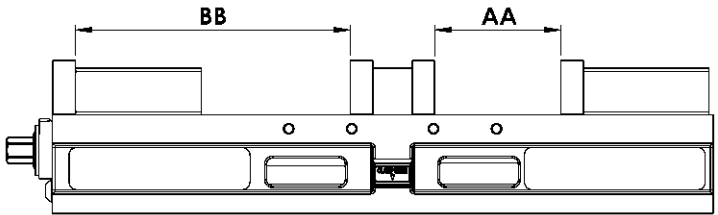

# SIDE & END VIEW

Fig.12

**Note:** Dimensions below are in inches unless specified.

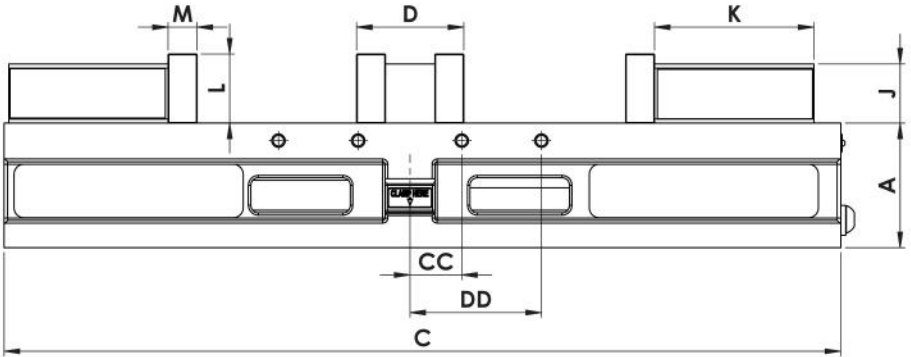

A	3.125
B	6.000
C	21.000
D	2.690
E	10.187
J	1.485
K	4.000
L	1.735
M	0.725
O	3.875
P	1/2-13
CC	1.300
DD	3.300

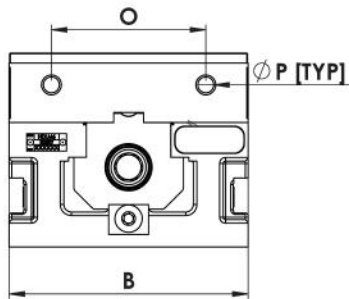

# MOUNTING LOCATIONS

Fig.13

**Note:** Dimensions below are in inches unless specified.

FF	1.000
GG	25 mm
HH	75 mm
II	3.19
JJ	5.000
KK	7.000
LL	175 mm
MM	2.000
NN	50 mm
OO	M12 SHCS
PP	1/2 SHCS
QQ	0.625 (5/8)
RR	M16
SS	3.918

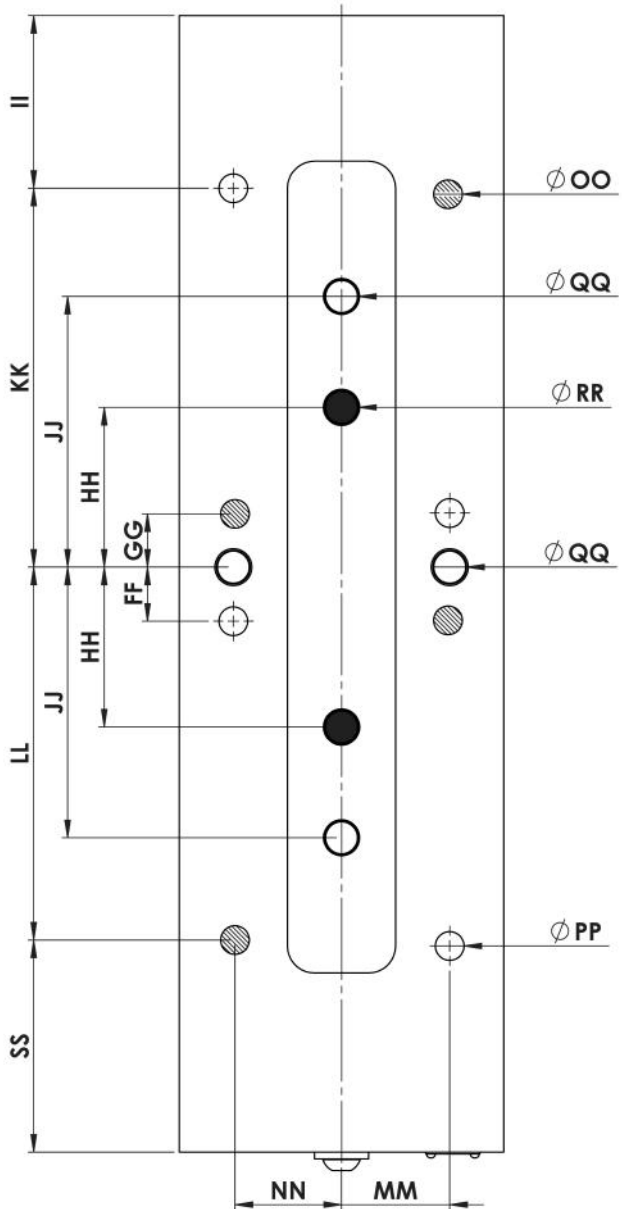



## SURFACE MOUNT USING SINE KEYS

Locating the HDHL6 with keys requires the use of sine keys instead of standard keys. Sine Keys are available in several different sizes that are listed on our website at [www.kurtworkholding.com](http://www.kurtworkholding.com). The keys are sold in sets of 2 per package.

### English Mounting:

The HDHL6 can be properly located using the four English sine key holes indicated by dimension QQ in figure 13. The HDHL6 can be bolted down using the four English 1/2" bolt holes indicated in figure 13 by dimension PP. The HDHL6 vise can also be clamped on the sides using toe clamps.

### Metric Mounting:

The HDHL6 can be properly located using the two Metric sine key holes indicated by Dimension RR in figure 13 above. The HDHL6 can be bolted down using the four Metric M12 bolt holes indicated in figure 13 by OO.

## PROPER CHIP GUARD INSTALLATION AND USAGE

Fig.14

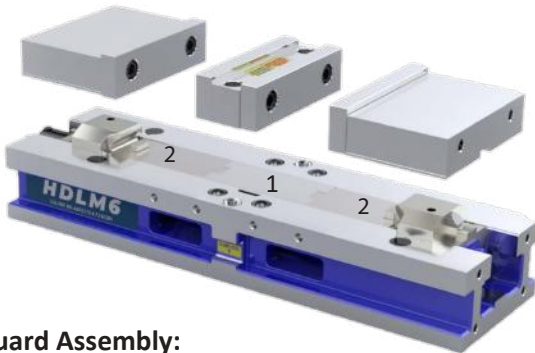

### Chip Guard Assembly:

The Chip Guard shown above is provided to keep chips from the nut and screw assembly.

The two side chip guards (#2 Fig. 14) should be placed so that the rectangular hole in the chip guards is placed over the rectangular peg on the nut.

The center chip guard (#1 Fig. 14) can be inserted so the key part of the chip guard is inserted into the notched area of the vise bed. This top chip guard will ride on top of the two side chip guards during clamping.

# HDHL(M)6 Parts List

ITEM NO.	PART NUMBER	DESCRIPTION	QTY.
1	HDM6-277A	PIN, LOCATING, STATIONARY JAW	2
2	HD6-209	CLAMP SLEEVE	2
3	HD6-35	CLAMP	2
4	26-0232	SHCS M10 X 1.5 X 45MM LG	2
5	HDHLM6-3R	REAR NUT	1
6	HDH6-93	PISTON RETAINING RING	1
7	HDH6-96	O-RING	2
8	HDH6-188	BACKER O-RING	1
9	HDH6-68	O-RING	2
10	HDH6-187	BACKER O-RING	2
11	360HU-87A	SPRING	2
12	HDHLM6-25	TIMING PIN	1
13	HDHLM6-89	PISTON SCREW	1
14	HDH6-334	PRELOAD PLUNGER	2
15	HD6-267	HYDRAUL IC SPRING	1
16	hdhm6-142 spring guide	SPRING GUIDE	2
17	B18.3.1M	5 x 0.8 x 8 Hex SHCS -- 8NHX	2
18	HDHLM6-168	PLUG	1
19	HDHLM6-3F	FRONT NUT	1
20	HDHLM6-5	SCREW EXTENSION	1
21	DL430-217	RETAINING RING	1
22	DL430-231	RETAINING RING	1
23	DL430-331	WIPER RING	2
24	DL430-97	WIPER RING	1
25	HD6-267	HYDRAUL IC SPRING	1
26	HDHLM6-169	SPRING	4
27	HDHLM6-225	FRICTION CLAMP	2
28	HDHLM6-311	PRELOAD SPRING	1
29	HDHLM6-53	COVER	1
30	HDHLM6-61	SPACER	1
31	B18.3.4M	10 x 1.5 x 10 SBHCS --N	1
32	HDL6-1	BODY, MACHINED	1
33	DL640-313R	WISE BODY STICKER, LEFT REAR	1
34	DL640-314R	WISE BODY STICKER (RIGHT REAR)	1
35	HDL6-102	MODEL/SERIAL NUMBER TAG	1
36	HDL6-223	STICKER, CAUTION	1
37	HDL6-313F	STICKER, LEFT FRONT	1
38	SCD600-111	CLAMP LOCATION STICKER	2
39	07-0230	U-TYPE DRIVE SCREW #2 X 1/4 LG	2
40	3600V-191	PROTECTIVE PLUG	4
41	DLU4-96	O-RING	4
42	HDL6-248	STATIONARY CHIP GUARD	1
43	HDL6-249	MOVABLE CHIP GUARD	2

# HDHL(M)6 Mechanical Drawing

Fig.15

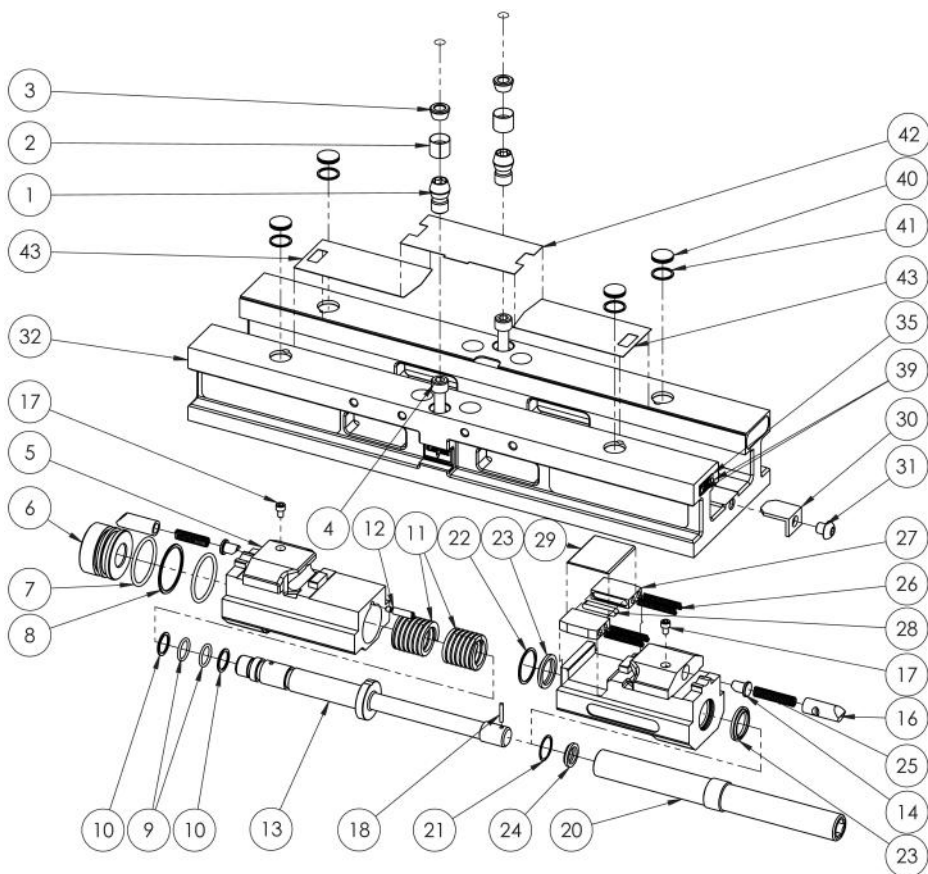

# Maintenance Schedule

It is very important to perform regular maintenance on your Kurt vise to ensure proper operation. Improper maintenance will result in poor vise performance and may void your warranty.

## Daily / Weekly

1. Remove chips from surface of vise.
2. Visually inspect seals for damage and cleanliness.
3. Visually inspect for chip entrapments and remove when necessary.
4. Air-dry and apply rust inhibiting oil to the machined surface of the vise.

## Monthly

1. Open the vise to the maximum opening.
2. Slide the Jaw slightly toward the stationary jaw and lift up to remove the jaw from the “beak” of the nut.
3. Turn the movable jaw over and clean the inside cavity.
4. Remove chips, clean and apply a light coat of machine oil to the machined surface of the following item:
  - a. Nut & Screw assembly (clean exposed threads on the screw)
  - b. Bed of vise (top of “rails”)
  - c. Inside of the vise between the center ways.
5. To re-assemble the movable jaw, press down on each of the quick jaws to lock into place
6. Your vise is now ready for use. Open and close your vise to check for proper operation. Center the part to be clamped in the vise and close. Your parts should be centered from side to side to ensure proper clamping.

## Disassembly Instructions

1. On the HDHL(M)6 (manual-long) model, start by removing the rear movable jaw and rotating the lead screw clockwise to close the vise.
2. Removing the M10 button head cap screw (#31 - Figure 15) and the "L" shaped bracket (#30 - Figure 15) located by the internal hex of the lead screw.
3. Remove the stationary and front jaws. Place a 4 3/4" long x 3/4" wide x 3/16" thick piece of stock between the rear nut and the positive stop on the machined nut rail support surface found on the inside floor of the body.
4. Turn the lead screw counter-clockwise to open the vise as this will push the front nut out of the vise body.
5. The nut and screw assembly can now be completely removed from the vise body.

## Assembly Instructions

1. On the HDHL(M)6 (manual-long) model, start by double checking the nut timing position before installing the nut and screw assembly into the vise body (See figure 16 below).
2. Slide the nut and screw assembly into the vise body up to the friction clamps (#27 - figure 15) on the front nut. Place the pull bar that came with the vise into the counter bored holes as shown in diagram 8 and start closing (Turn the screw clockwise) the vise.
3. Once the friction clamps are inside the vise body, continue closing until there is room to install the "L" shaped bracket spacer and M10 button head cap screw (Items #30 & #31 - figure 15).
4. Open the vise to free up the pull bar and remove it. Remount the jaws. The vise is now read for use.

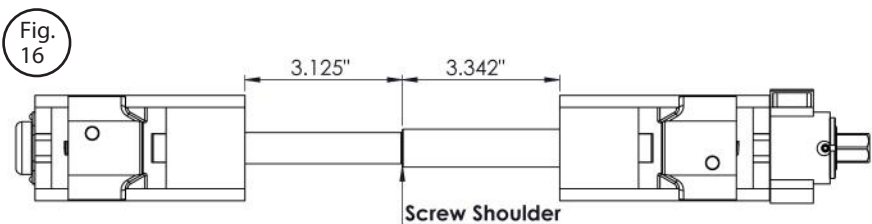

Reset Timing - Rotate Nuts until the Spacing above is achieved

## Troubleshooting Tips

If properly maintained, the Kurt HDHL6 Series vise will operate trouble free for many years. In some cases it will be necessary to troubleshoot. Use the information below to help in the process.

**Problem:** My vise turns hard.

Tip: As a new vise the brush seal could be stiff. Allow for break in of vise.

Tip: As a used vise, it could be filled with chips and threads could be jammed. Properly clean and grease vise.

**Problem:** My vise will not turn in either direction.

Tip: The vise is jammed with debris. Disassemble and clean as needed.

**Problem:** My vise won't hold tolerance.

Tip: You may be experiencing jaw lift from clamping too high or on one side of the jaw. Lower the part in the vise jaw and clamp more material.



# LIFETIME WARRANTY IRON CLAD™

All Kurt Manufacturing Company industrial workholding products and parts with the exceptions noted below, are warranted against defects in material and workmanship for the life of the product or part. (The life of the product is defined as that point in time when such item no longer functions due to normal wear and tear.) Failure to properly maintain and/or properly operate the product or part that has been worn out, abused heated ground or otherwise altered, used for a purpose other than that for which it was intended, or used in a manner inconsistent with any instructions regarding its use. The sole obligation of Kurt Manufacturing Company, Inc. (Kurt) and the purchaser's SOLE AND EXCLUSIVE REMEDY hereunder, shall be limited to the replacement or repair of any Kurt product or part (by an authorized Kurt technician) which are returned to Kurt Manufacturing Company's place of business, transportation, shipping and postal charges prepaid, and there determined by Kurt Manufacturing Company to be covered by the warranty contained herein.

THE LIMITED WARRANTY DESCRIBED HEREIN IS MADE EXPRESSLY IN LIEU OF ANY OTHER EXPRESSED OR IMPLIED WARRANTIES, INCLUDING ANY IMPLIED WARRANTY OF MERCHANTABILITY OR FITNESS FOR A PARTICULAR PURPOSE. KURT MANUFACTURING COMPANY IS NOT RESPONSIBLE FOR THE IMPROPER USE OF ITS PRODUCTS. KURT SHALL NOT BE LIABLE FOR ANY DIRECT, INDIRECT, INCIDENTAL SPECIAL OR CONSEQUENTIAL DAMAGES, INCLUDING BUT NOT LIMITED TO, LOSS OF USE, REVENUE OR PROFIT.

KURT ASSUMES NO LIABILITY FOR, AND MAKES NO WARRANTY REGARDING ANY PURCHASE ITEMS WHERE THE MANUFACTURER OF SUCH ITEM EXTENDS A SEPARATE WARRANTY.





**KURT** WORKHOLDING

**Thank you for your  
purchase! If you  
have any feedback  
or questions please  
contact us at.**

[kurtworkholding.com](http://kurtworkholding.com) |

**Kurt Industrial Products//A Division Of Kurt Manufacturing**

9445 East River Road NW | Mpls, MN 55433 | [workholding@kurt.com](mailto:workholding@kurt.com)

Phone 763-574-8309 | Toll Free 877-226-7823

Fax 763-574-8318 | Toll Free Fax 877-226-7823

Manual Revision:  
4.1.2022