



**KURT** WORKHOLDING

# SCD640 SELF-CENTERING VISE

Operating Instruction Manual  
SCD640



ENGLISH

# TABLE OF CONTENTS

Introduction .....	3
Setup Instructions .....	4
Operating Instructions.....	5-9
Mounting & Chip Guard Instructions.....	10
Centerline & Gibs Adjustment .....	11
SCD640 Parts List.....	12
SCD640 Mechanical Drawing .....	13
Maintenance Schedule .....	14-15
Troubleshooting Tips .....	16
Maintenance Log/Notes .....	17
Warranty .....	18

## WISE DATA

Use this to fill out information about your vise for quick reference.

Purchase Date: \_\_\_\_\_ - \_\_\_\_\_ - \_\_\_\_\_

Purchase Order: \_\_\_\_\_

Purchased From: \_\_\_\_\_

Delivery Date: \_\_\_\_\_

Serial No.: \_\_\_\_\_

**NOTE: MAKE SURE TO REGISTER YOUR WARRANTY ONLINE AT  
KURTWORKHOLDING.COM**

# INTRODUCTION

Thank you for purchasing a Kurt SCD640 vise. You have just purchased one of the best machine vises in the industry. The outstanding accuracy of this product is second to none. Backed by a lifetime warranty against workmanship and material defects, this product is built to last when used and maintained properly.

The original Kurt Anglock vises are designed for precision clamping on basic machine tools such as knee-type mills and machining centers. They can be used for, but are not limited to, operations like precision boring, drilling, tapping, & finishing.

The patented Anglock design allows the movable jaw to advance in such a way that each pound of force forward induces a 1/2 pound of force downward which minimizes the jaw lift and increases accuracy. This, combined with the needle bearings, increases jaw clamping pressure. Other features include: 80,000 psi ductile iron body, hardened vise bed & jaw plates, and a semi-hard steel screw.

Fig.1

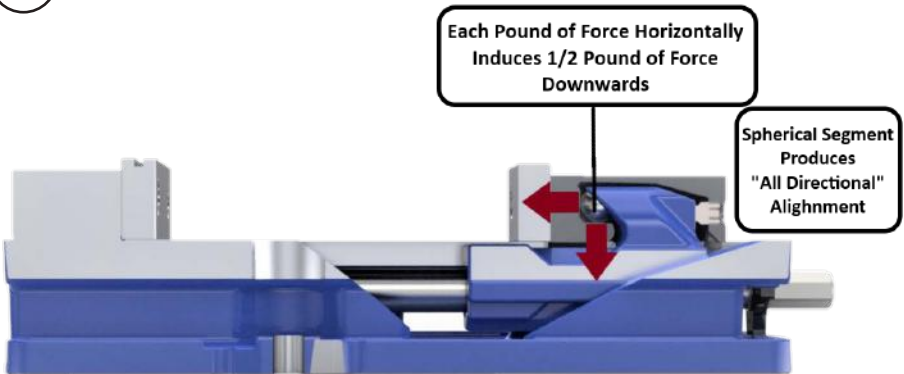

## SET-UP INSTRUCTIONS

Now that you have your new Kurt Vise, it's time to set-up and begin using it. You will see that your new vise comes with a Kurt swivel handle and chip guard in the shipping carton (instruction manual available online at [www.kurtworkholding.com](http://www.kurtworkholding.com)). The chip guard rests between the ways of the vise and can be trimmed to size (see pg. 10) to help keep the chips away from the screw. The handle is specifically designed to provide maximum torque to your vise ( clamping force provided below). Your vise should be mounted to a clean, flat surface. The surface and the vise must be free of any chips, dirt, or debris of any kind. The mounting surface can be honed if necessary. Clean the bottom of the vise with solvent or another cleaner if needed.

To minimize vise bed deflection, clamp your Kurt vise to your machine table, pallet, or sub-plate using the built-in clamping slots or through the body holes provided.

Additional clamping can be used, but may not be necessary. Please be sure to exercise good judgment when securing your vise to the mounting surface. Be sure your vise is secured and will not move when applying the machine pressure.

<b>Torque Ft.-Lbs.</b>	<b>SCD640</b>	<b>Clamping Force - Lbs</b>
10		975
20		1750
30		2575
40		3750
50		4375
60		5750

# OPERATING INSTRUCTIONS

For proper vise operation, insert the handle on to the hex end of the vise. Rotate clockwise to clamp and counterclockwise to unclamp your vise. This handle, combined with the correct amount of torque, will provide you with all the clamping force you will need to machine your parts. **DO NOT** use any other type of pressure to open or close your vise.

**The uses of handle extensions, air impact wrenches, breaker bars, or hammer strikes are not recommended and will void the warranty if used. This will also cause damage to the thrust bearing and screw threads. If you need more clamping force you may require a larger vise.**

To properly clamp a part in your Kurt vise, you should place the part in the center of the jaws resting on the ways of the vise. Clamping only on one side or above the movable and stationary jaws can result in jaw lift or loss of accuracy. (See Fig. 2 on next page)

If one-sided clamping is necessary, you **MUST** use a dummy part on the other side. When using parallels or step jaws, you must select a size that keeps the bottom of the clamped part at or below the top of the movable and stationary jaws. Always use jaw plates for clamping. If jaw plates are not used, damage to the mounting surface of the movable and stationary jaw will occur. This will result in reduced clamping accuracy and repeatability.

Fig.2

**Sketch #2A**

Incorrect part clamping.

Vise width centerline

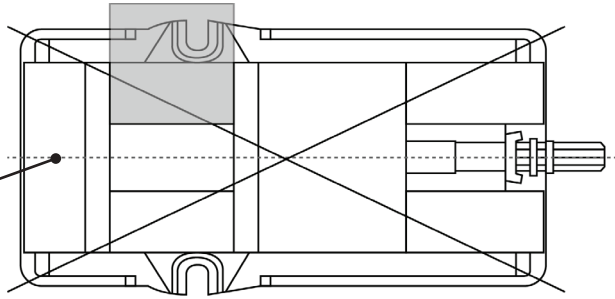

**Sketch #2B**

Correct part clamping.

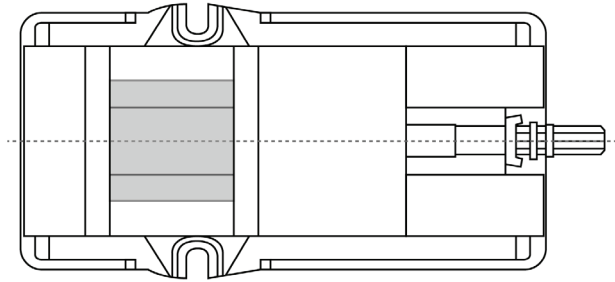

**Sketch #2C**

Correct part clamping.

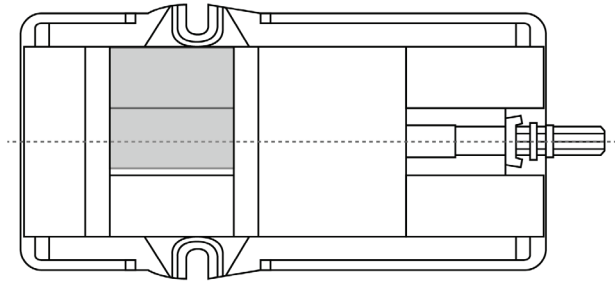

**Sketch #2D**

Correct part clamping.

Dummy spacer

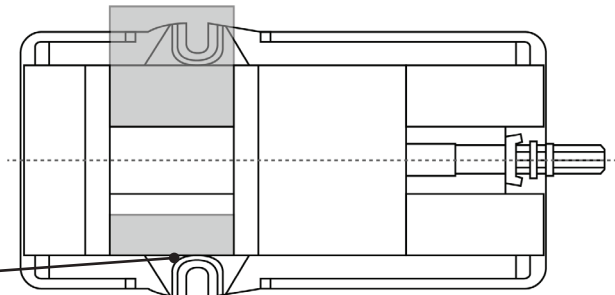

# JAW PLATE POSITIONING

Fig.3

**Note:** Dimensions below are in inches unless specified.

LL	1.000
MM	8.000
NN	7.240
OO	14.240
PP	13.470
QQ	20.470

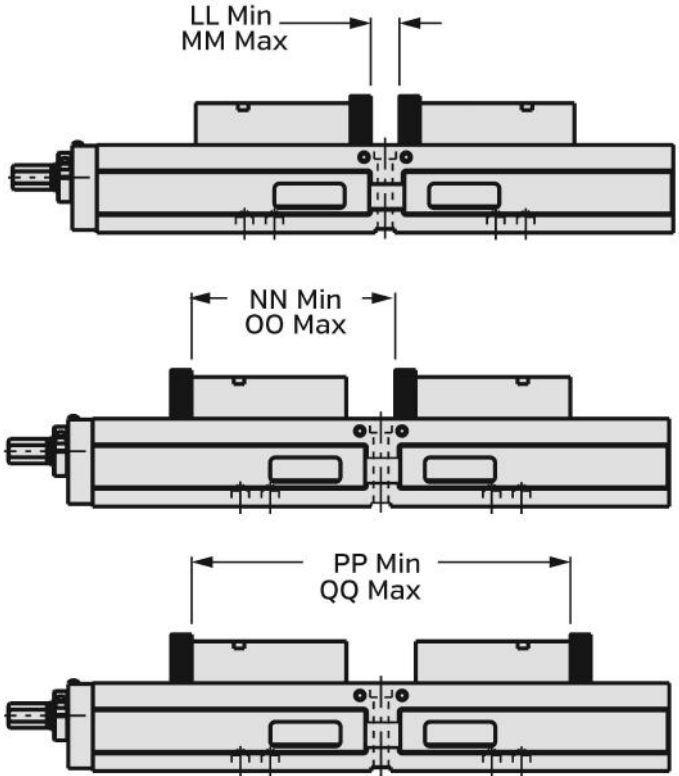

# SIDE & END VIEW

Fig.4

**Note:** Dimensions below are in inches unless specified.

A	3.125
B	6.000
C	20.500
D	10.250
E	0.6880
F	3.000
G	3/4
H	1.485
J	5.500
K	4.000
L	0.375
M	0.250
N	0.500
O	4.000
P	5.000
Q	1/2-13
R	1.735
S	0.725
T	0.940
U	3.875
V	1/2-13
W	1.156
X	0.880
Y	0.850
Z	0.360
AA	0.690
BB	1.470
DD	5.500
KK	1/2
LL	1.000
MM	8.000

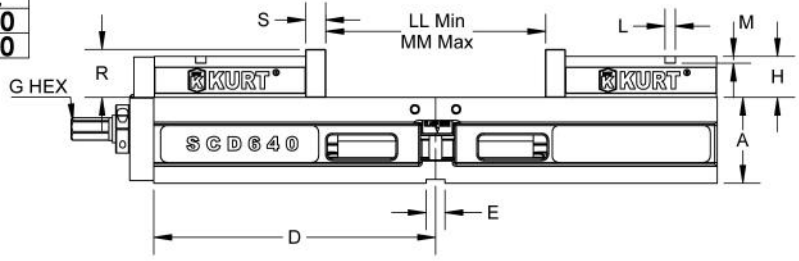
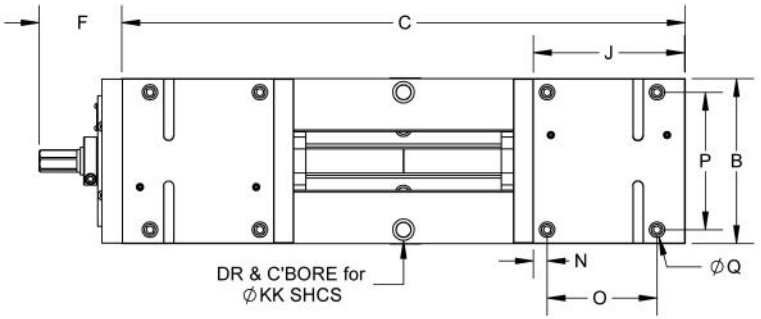
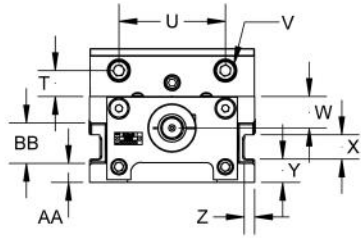



# MOUNTING LOCATIONS

Fig.5

**Note:** Dimensions below are in inches unless specified.

CC	1.188
DD	5.500
EE	5.000
FF	3.937
GG	0.625
HH	0.630
JJ	3/8
KK	1/2
RR	5.000
SS	4.000
TT	2.376

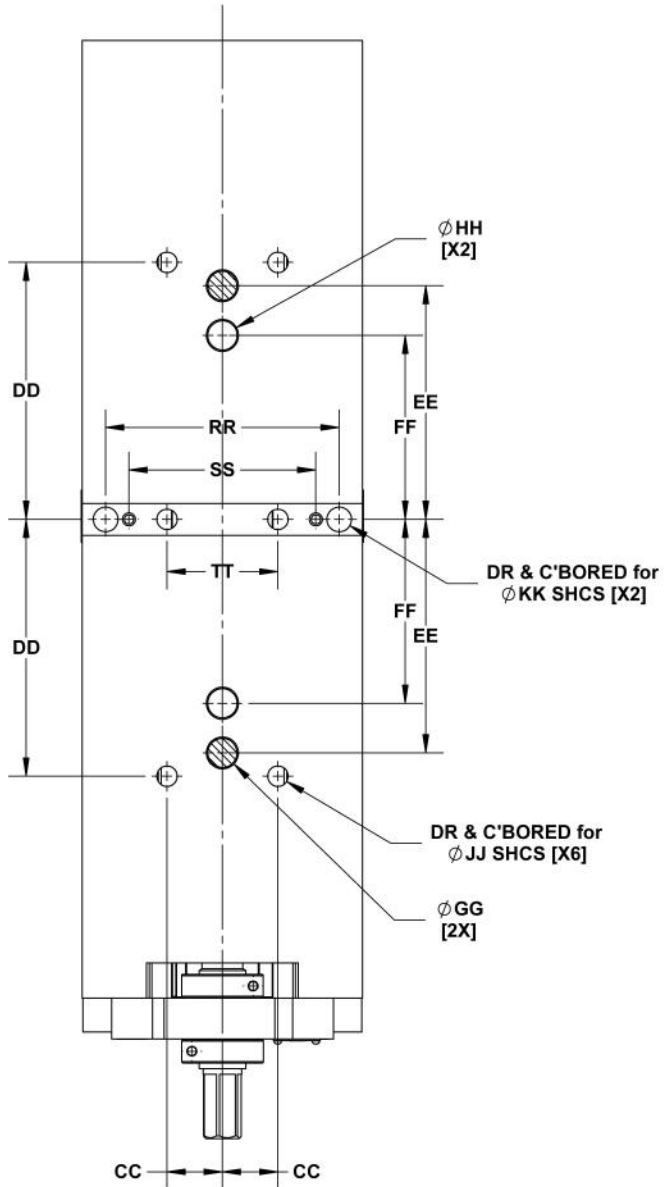

# SURFACE MOUNT USING SINE KEYS

Locating the SCD640 with keys requires the use of sine keys or standard keys. They are available in several different sizes that are listed on our website at [www.kurtworkholding.com](http://www.kurtworkholding.com). The keys are sold in sets of 2 per package.

## English Mounting:

The SCD640 can be properly located using the two English sine key holes indicated by the GG's in figure 5 above. The SCD640 can be bolted down using the six 3/8" bolt holes indicated in figure 5 above by JJ or by the two 1/2 bolt holes indicated by KK. The SCD640 vise can also be mounted using toe clamps on the sides of the vise.

## Metric Mounting:

The SCD640 can be properly located using the two Metric sine key holes indicated by the HH's in figure 5 above.

## PROPER CHIP GUARD INSTALLATION AND USAGE

1. Clamp part in the vise.
2. Cut a piece of chip guard material long enough to extend underneath the jaw plates (#22, Figure 6).
3. Unclamp part and open jaws to fit new cut chip guard into the notch in the center way.
4. Re-clamp the part making sure the jaw plates cover the top of the chip guard and that no binding occurs.
5. Place another piece of chip guard material in the front of the vise. Cut the piece to length so it extends underneath the retaining plate.
6. Secure the chip guard to the holding block using the two button head cap screws (#15, Figure 6).



### CAUTION:

Use caution when handling chip guard material. Edges and corners are very sharp. Failure to take caution could result in personal injury.

# Centerline Adjustment

The SCD640 is equipped with a feature that allows for centerline adjustment. It might not be necessary to adjust the centerline unless more than one vise is used. If using more than one vise, following the procedure below to have the centerlines of all the vises in line with one another:

1. Lightly clamp a parallel block between the jaws.
2. Loosen the lock screw in both of the threaded shaft collars near the handle end of the vise.
3. Holding the lead screw from turning, rotate each collar until the centerlines have been adjusted.
4. Tighten threaded shaft collars to holding block while preventing the screw from turning.
5. Tighten lock screws in both threaded shaft collars.

## Adjusting Gibs for Accuracy

The SCD640 also has adjustable gibs in each movable jaw to allow for maximum accuracy. There are two gibs in each movable jaw and can be adjusted to provide a close running fit with the center way. For most applications, one movable jaw should be adjusted to have a close running fit with the center way; this will become a reference surface. The other movable should remain loose so it can pivot and adjust for any non-parallelism of the work piece. The procedure for adjusting the gibs is as follows:

1. Remove the two slotted head set screws located on the top surface of the movable jaw. These are just plugs and allow access to gib adjustment set screws
2. Pressure on the gib is accomplished through the use of a set screw in the movable jaw. By tightening or loosening the set screw, you can increase or decrease the amount of pressure applied on the gib.
3. Adjust gib as desired.
  - Too much pressure on the gibs will make the screw hard to turn.
  - Too little pressure on the gibs will result in a loose movable jaw that is able to pivot.
  - Both the front and rear gibs on each movable jaw should be adjusted with the same amount of pressure.
4. After the gibs have been properly adjusted, reinstall the two slotted set screws.

# SCD640 Parts List

ITEM NO.	PART NO.	DESCRIPTION	QTY
1	SCD640-1	BODY	1
2	DL600-218	END CAP	1
3	07-0230	SCREW, DRIVE, #2 X .25	2
4	SCD640-3R	NUT, REAR	1
5	SCD600-146	SEAL, U-CUP	3
6	SCD600-5-CP	SCREW	1
7	SCD640-3F	NUT, FRONT	1
8	D60-42	THRUST WASHER	4
9	D60-41	THRUST BEARING	2
10	SCD600-60	BUSHING, SPLIT	1
11	SCD600-212	HOLDING BLOCK	1
13	00-1353	SHCS 3/8-16 X 7/8 LG	2
14	03-2036	SCREW, SHLDR, 1/2 X 1/2 LG	2
15	03-0124	BHCS 10-24 X 3/8 LG	2
16	SCD600-8	SHAFT COLLAR	2
17	00-1412	SHCS 1/2-13 X 5/8 LG	2
18	SCD600-227	RETAINING PLATE	1
19	01-3335	SHSS 1/2-13 X 1-1/4 LG	2
20	SCD600-2S	MOVABLE JAW, SPECIAL	2
21	D60-9	SEGMENT	2
22	D60-7	JAW PLATE	2
23	00-1414	SHCS 1/2-13 X 3/4 LG	4
25	D60I-10-SA	HANDLE ASSEMBLY	1
26	DL600-248	SHORT CHIP GUARD	1
27	DL600-249	LONG CHIP GUARD	1
28	01-1133	SHSS 1/2-13 X 1/2 LG	8
29	SCD640-13	GIB, MOVABLE JAW	4
30	01-3878E	SHSS 1/4-20 X 3/4 LG	4
31	01-1088	SHSS 5/16-18 X 5/16 LG	4

# SCD640 Mechanical Drawing

Fig.6

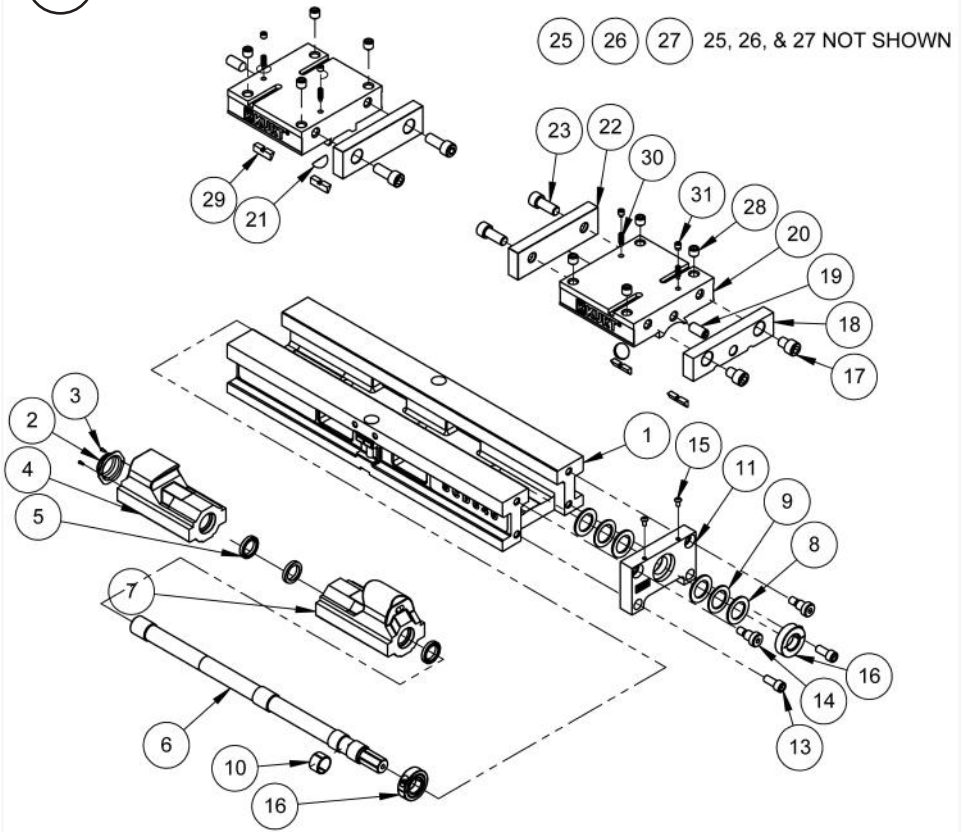

# Maintenance Schedule

It is very important to perform regular maintenance on your Kurt vise to ensure proper operation. Improper maintenance will result in poor vise performance and may void your warranty.

## Daily/ Weekly

1. Remove chips from surface of vise.
2. Visually inspect seals for damage and cleanliness.
3. Visually inspect for chip entrapments and remove when necessary.
4. Air-dry and apply rust inhibiting oil to the machined surface of the vise.

## 3 to 6 Months

1. Open the vise until the long end of an Allen wrench can be inserted into the socket head set screw in the back of the movable jaw (#20 in figure 6). Note: the backside of the movable jaw has (3) drilled and tapped holes.
2. Loosen the setscrew (#19 in figure 6) but do not remove. Turn out until the face of the set screw is approximately 1/4" beyond the backside of the movable jaw.
3. With the Allen wrench still in place, lift upward allowing the movable jaw to pivot off the nut (#4 & #7 in figure 6). Note: there is a segment (#21, figure 6) in the shape of a half sphere in the movable jaw cavity. Be careful not to misplace while cleaning.
4. Remove all chip guards.
5. Clean out any chips that may have built up underneath the movable jaw and in the center ways of the vise bed.
6. Remove the threaded shaft collar(#16, figure 6) near the hexed end of the screw (#6, figure 6). Note: Do not loosen or remove the rear-threaded shaft collar, this will insure the centerline of the jaws stay in the same place after reassembly.
7. Remove the holding block (#11, figure7).
8. Clean and inspect both sets of the thrust bearing assemblies (#'s 8 & 9, figure 6).
9. Apply water-resistant grease to the thrust bearings (#9, figure 6).
10. Re-install the holding block.

## 3 to 6 months

11. Install the threaded collar. While holding screw from turning, lightly snug threaded collar to the holding block. Tighten lock screw on the collar.
12. Inspect the wiper seals (#5, fig. 6) on the nuts. Remove any chip build up.
13. Oil all exposed surfaces of the screw and apply a small film to the top surface of the vise bed.
14. Apply a generous amount of grease into the cavity and place the half sphere segment back in the movable jaw cavity. The flat surface will match up with the angle of the nut once reassembled.
15. Re-install the movable jaw, assuring the segment is properly in place.
16. While pulling back on the movable jaw, tighten the set screw.
17. Back off the screw 1/8 of a turn counter clockwise. The setscrew must not be tightened all the way.
18. Close the movable jaws tightly. This will set the segment to its proper orientation. Open the movable jaws.

## Troubleshooting Tips

If properly maintained, The Kurt SCD640 vise will operate trouble free for many years. In some cases, it will be necessary to troubleshoot. Use the information below to help in the process.

**Problem:** My vise turns hard.

**Tip:** Allow for break in of vise.

**Tip:** As a used vise, it could be filled with chips and threads could be jammed. Properly clean and grease vise.

**Tip:** The set screw in the back of the movable jaws may be too tight. Back off the set screw an 1/8 of a turn counter-clockwise.

**Problem:** My vise will not turn in either direction.

**Tip:** The vise is jammed with debris. Disassemble and clean as needed.

**Problem:** My vise won't hold tolerance.

**Tip:** You may be experiencing jaw lift from clamping too high or on one side of the jaw. Lower the part in the vise jaw and clamp more material.

**Problem:** My vise is stiff when clamping on a part or is difficult to back off a part.

**Tip:** The vise's thrust bearing pack may need to be replaced.

**Problem:** My vise is not clamping at a high clamping force.

**Tip:** The vise's thrust bearing pack may need to be replaced.





# LIFETIME WARRANTY IRON CLAD™

All Kurt Manufacturing Company industrial workholding products and parts with the exceptions noted below, are warranted against defects in material and workmanship for the life of the product or part. (The life of the product is defined as that point in time when such item no longer functions due to normal wear and tear.) Failure to properly maintain and/or properly operate the product or part that has been worn out, abused heated ground or otherwise altered, used for a purpose other than that for which it was intended, or used in a manner in consistent with any instructions regarding its use. The sole obligation of Kurt Manufacturing Company, Inc. (Kurt) and the purchaser's SOLE AND EXCLUSIVE REMEDY hereunder, shall be limited to the replacement or repair of any Kurt product or part (by an authorized Kurt technician) which are returned to Kurt Manufacturing Company's place of business, transportation, shipping and postal charges prepaid, and there determined by Kurt Manufacturing Company to be covered by the warranty contained herein.

THE LIMITED WARRANTY DESCRIBED HEREIN IS MADE EXPRESSLY IN LIEU OF ANY OTHER EXPRESSED OR IMPLIED WARRANTIES, INCLUDING ANY IMPLIED WARRANTY OF MERCHANTABILITY OR FITNESS FOR A PARTICULAR PURPOSE. KURT MANUFACTURING COMPANY IS NOT RESPONSIBLE FOR THE IMPROPER USE OF ITS PRODUCTS. KURT SHALL NOT BE LIABLE FOR ANY DIRECT, INDIRECT, INCIDENTAL SPECIAL OR CONSEQUENTIAL DAMAGES, INCLUDING BUT NOT LIMITED TO, LOSS OF USE, REVENUE OR PROFIT.

KURT ASSUMES NO LIABILITY FOR, AND MAKES NO WARRANTY REGARDING ANY PURCHASE ITEMS WHERE THE MANUFACTURER OF SUCH ITEM EXTENDS A SEPARATE WARRANTY.



**KURT** WORKHOLDING

**Thank you for your  
purchase! If you  
have any feedback  
or questions please  
contact us at.**

[kurtworkholding.com](http://kurtworkholding.com) |

**Kurt Industrial Products//A Division Of Kurt Manufacturing**

9445 East River Road NW | Mpls, MN 55433 | [workholding@kurt.com](mailto:workholding@kurt.com)

Phone 763-574-8309 | Toll Free 877-226-7823

Fax 763-574-8318 | Toll Free Fax 877-226-7823

Manual Revision:  
9.8.2022