



KURT WORKHOLDING

DX8™ CROSSOVER™ ANGLOCK® VISE BASE ASSEMBLY

Operating Instruction Manual
DX8/DX8R



ENGLISH

TABLE OF CONTENTS

Introduction	3
Set-Up Instructions	4
Operating Instructions.....	5-11
DX8 Parts List	12
DX8 Mechanical Drawing	13
DX8R Parts List.....	14
DX8R Mechanical Drawing.....	15
Maintenance Schedule.....	16-18
Troubleshooting Tips.....	19
Maintenance Log/Notes.....	20-22
Warranty.....	23

WISE DATA

Use this to fill out information about your vise for quick reference.

Purchase Date: _____ - _____ - _____

Purchase Order: _____

Purchased From: _____

Delivery Date: _____

Serial No.: _____

NOTE: MAKE SURE TO REGISTER YOUR WARRANTY ONLINE AT KURTHOLDING.COM

INTRODUCTION

Thank you for purchasing a Kurt DX8 vise. You have just purchased one of the best machine vises in the industry. The outstanding accuracy of this product is second to none. Backed by a lifetime warranty against workmanship and material defects, this product is built to last when used and maintained properly.

The original Kurt Anglock vises are designed for precision clamping on basic machine tools such as knee-type mills and machining centers. They can be used for, but are not limited to, operations like precision boring, drilling, tapping, & finishing.

The patented Anglock design allows the movable jaw to advance in such a way that each pound of force forward induces a 1/2 pound of force downward which minimizes the jaw lift and increases accuracy (Fig.1). This, combined with the needle bea rings, increases jaw clamping pressure. Other features include: 80,000 psi ductile iron body, hardened vise bed & jaw plates, and a semi-hard steel screw.

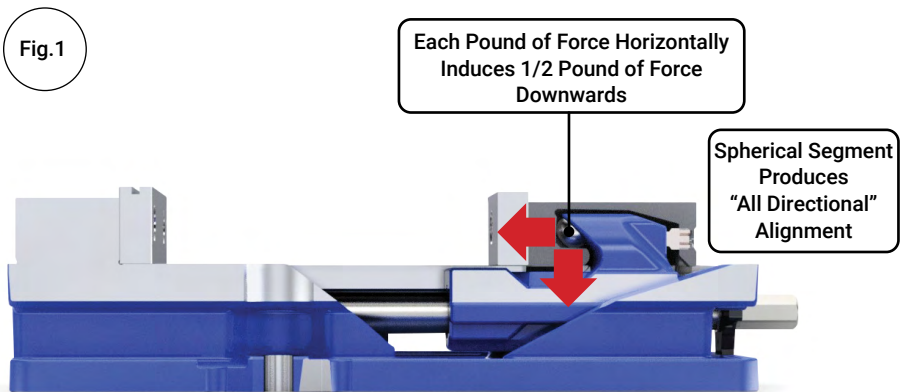

SET-UP INSTRUCTIONS

Now that you have your new Kurt Vise, it's time to set-up and begin using it. Your Kurt vise comes with a swivel handle in the shipping carton (instruction manual available online at www.kurtworkholding.com). The handle is specifically designed to provide maximum torque to your vise (clamping force provided below). Your vise should be mounted to a clean, flat surface. The surface and the vise must be free of any chips, dirt, or debris of any kind. The mounting surface can be honed if necessary. Clean the bottom of the vise with solvent or another cleaner if needed.

To minimize vise bed deflection, clamp your Kurt vise to your machine table, pallet, or sub-plate using the built-in clamping slots or through the body holes provided.

Additional clamping can be used, but may not be necessary. Please be sure to exercise good judgment when securing your vise to the mounting surface. Be sure your vise is secured and will not move when applying the machine pressure.

TORQUE/CLAMPING FORCE TABLES

DX8 / DX8R	
TORQUE FT-LBS	FORCE IN LBS.
10	850
20	1,500
30	2,200
40	3,000
50	3,600
60	4,100
70	4,850
80	5,500
90	5,900
100	6,200

OPERATING INSTRUCTIONS

For proper vise operation, insert the handle on to the hex end of the vise. Rotate clockwise to clamp and counterclockwise to unclamp your vise. This handle, combined with the correct amount of torque, will provide you with all the clamping force you will need to machine your parts. **DO NOT** use any other type of pressure to open or close your vise.

The uses of handle extensions, air impact wrenches, breaker bars, or hammer strikes are not recommended and will void the warranty if used. This will also cause damage to the thrust bearing and screw threads. If you need more clamping force you may require a larger vise.

To properly clamp a part in your Kurt vise, you should place the part in the center of the jaws resting on the ways of the vise. Clamping only on one side or above the movable and stationary jaws can result in jaw lift or loss of accuracy. (See Fig.2 on page 6)

If one-sided clamping is necessary, you **MUST** use a dummy part on the other side. When using parallels or step jaws, you must select a size that keeps the bottom of the clamped part at or below the top of the movable and stationary jaws. Always use jaw plates for clamping. If jaw plates are not used, damage to the mounting surface of the movable and stationary jaw will occur. This will result in reduced clamping accuracy and repeatability.

Fig.2

Sketch #2A

Incorrect part
clamping.

Vise width
centerline

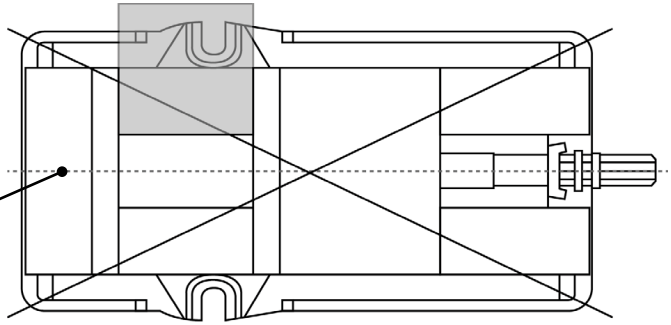

Sketch #2B

Correct part
clamping

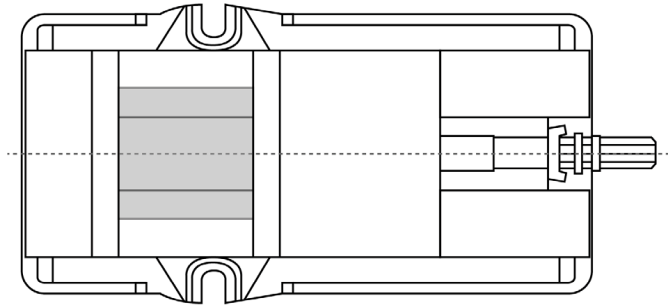

Sketch #2C

Correct part
clamping

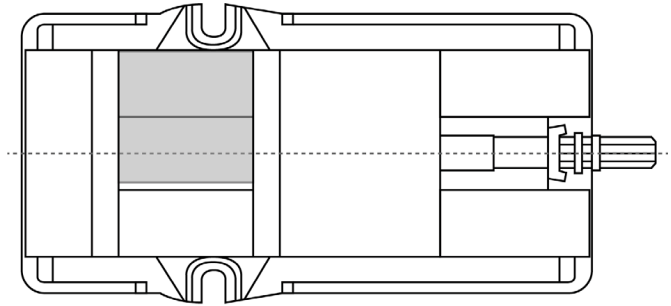

Sketch #2D

Correct part
clamping

Dummy
spacer

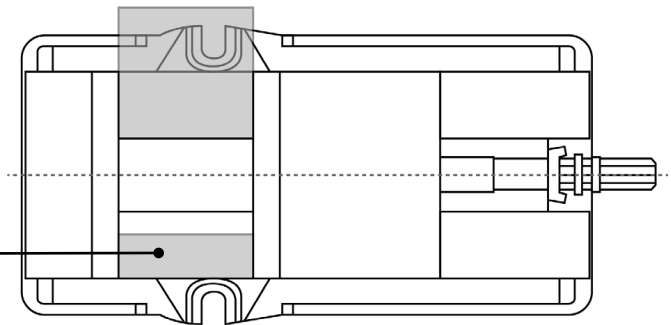

Fig.3

JAW POSITIONING

Note: Dimensions below are in inches unless specified.

AA	10.63
BB	15.36
CC	17.71
DD	22.44

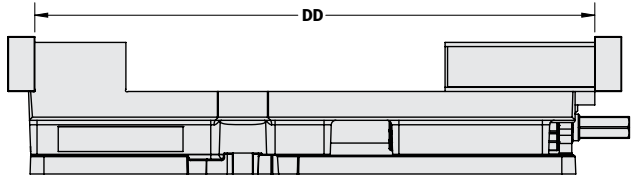
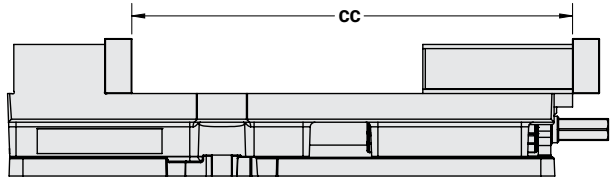
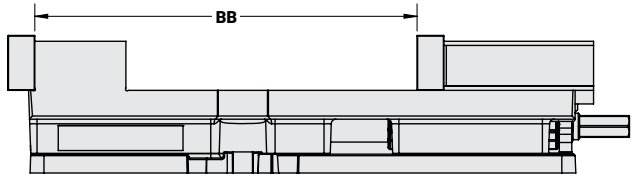
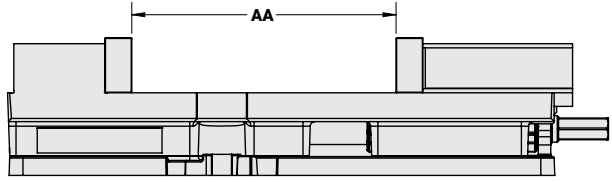
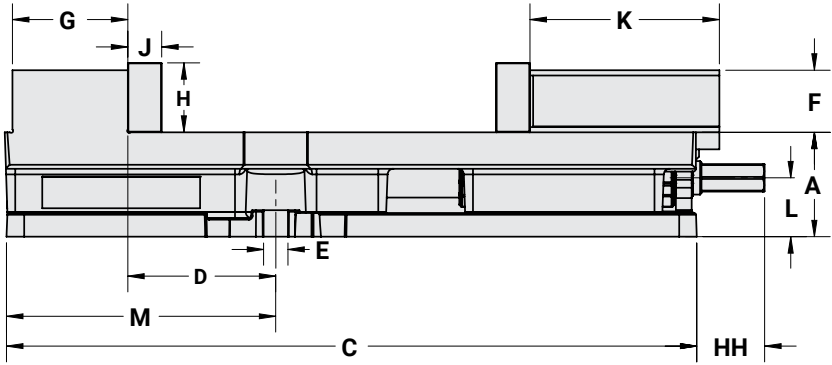

Fig.4

SIDE & END VIEW

Note: Dimensions below are in inches unless specified.



A	3.310
B	8.000
C	21.865
D	4.685
E	0.770
F	1.965
G	3.652
H	2.200
I	8.987
J	1.075
K	6.570
L	1.865
M	8.527
N	1.220
O	4.750
P	0.531
HH	2.151

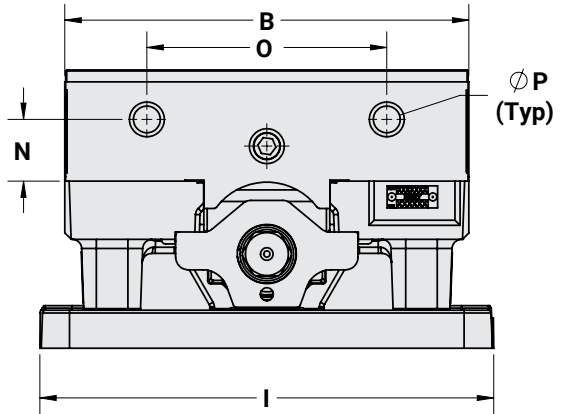
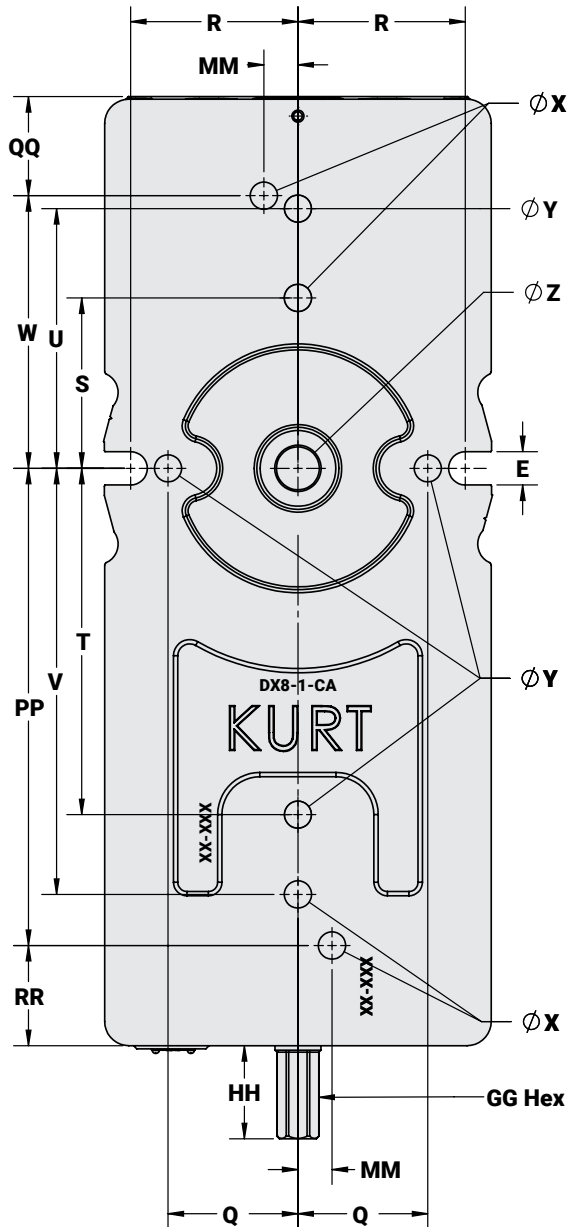

Fig.5

MOUNTING LOCATIONS

Note: Dimensions below are in inches unless specified.

E	0.770
Q	3.000
R	3.866
S	100 mm
T	8.000
U	6.000
V	250 mm
W	160 mm
X	16 mm
Y	0.625
Z	1.072
GG	7/8
HH	2.15
MM	20 mm
PP	280 mm
QQ	2.29
RR	2.31



SURFACE MOUNT USING SINE KEYS

Mounting the new DX8 with keys requires the use of sine keys instead of standard keys. They are available in several different sizes that are listed on our website at www.kurtworkholding.com. The keys are sold in sets of 2 per package.

English Mounting:

The DX8 can be properly located using the four English sine key holes indicated by the Y's in Fig.5 on page 9. The DX8 vise can also be mounted using both bolt slots on the sides of the vise.

Metric Mounting:

The DX8 can be properly located using the four Metric sine key holes indicated by the X's in Fig.5.

PROPER CHIP GUARD* INSTALLATION AND USAGE

Fig.6

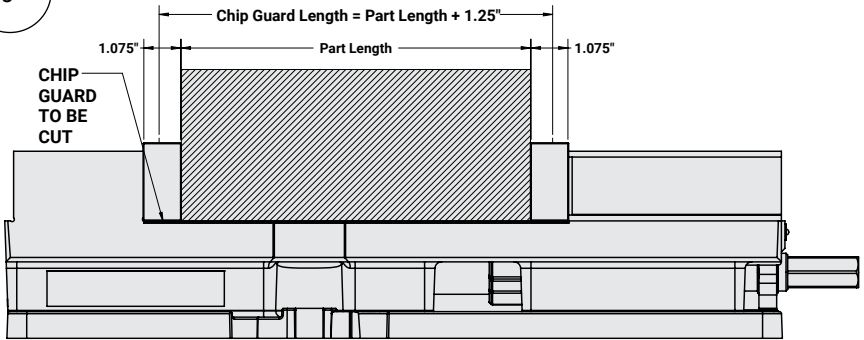

CAUTION

Chip Guard* stock shown above keep chips from the nut and screw assembly and must be cut and deburred to meet your application and safety needs.

Example: Part plus 1-1/4 inch = Length of Chip Guard.

NOTE: Remove Chip Guard stock. If left uncut, the excess material could cause injury.

*Chip guard not included – available as an accessory at www.kurtworkholding.com.

DX8 PARTS LIST

ITEM#	PART#	DESCRIPTION	QTY.
1	DX8-1	Body	1
2	DX8-2	Movable Jaw	1
3	DX8-3	Nut	1
4	DX8-5	Screw	1
5	D80-7	Jaw Plate	1
6	3800V-8	2-piece Retaining Nut	1
7	D80-9	Segment	1
8*	3800V-41	Thrust Bearing	1
9*	3800V-42	Thrust Bearing Washer	2
10*	3800V-99	O-ring #121	1
11*	3800V-128	O-ring #224	1
12*	3800V-147	Spiral Retaining Ring	2
13*	DX8-169	Wave Spring	2
14*	PT800-211	Internal Brush Seal	2
15	DX8-22	Sticker, Body	2
16	DX8-224-CP	Screw Support	1
17	HDHLM4-102	Model Tag	1
18	00-1197	SHCS 8-32 X 0.75 Lg	6
19	00-1481	SHCS 5/8-11 X 1.25 Lg	4
20	01-3953	CHDOG SHSS 5/8-11 X 1.25 Lg	1
21	07-0230	U-Type Drive Screw (not shown)	2
22**	D80XL-248	Chip Guard (not shown)	1
23	D80I-10-SA	Handle Assembly (not shown)	1
24	3800V-111	Kurt Logo Tag (not shown)	2
Kurt's Repair Kit DX8-KIT, Includes the Following Parts:		D80-41, 3800V-42 (QTY-2), 3800V-99, PT800-211 (QTY-2) 3800V-128, 3800V-147, DX8-169 (QTY-2)	
* Indicates Part is included in the DX8-KIT			
** Chip guard not included – available as an accessory at www.kurtworkholding.com .			

DX8 MECHANICAL DRAWING

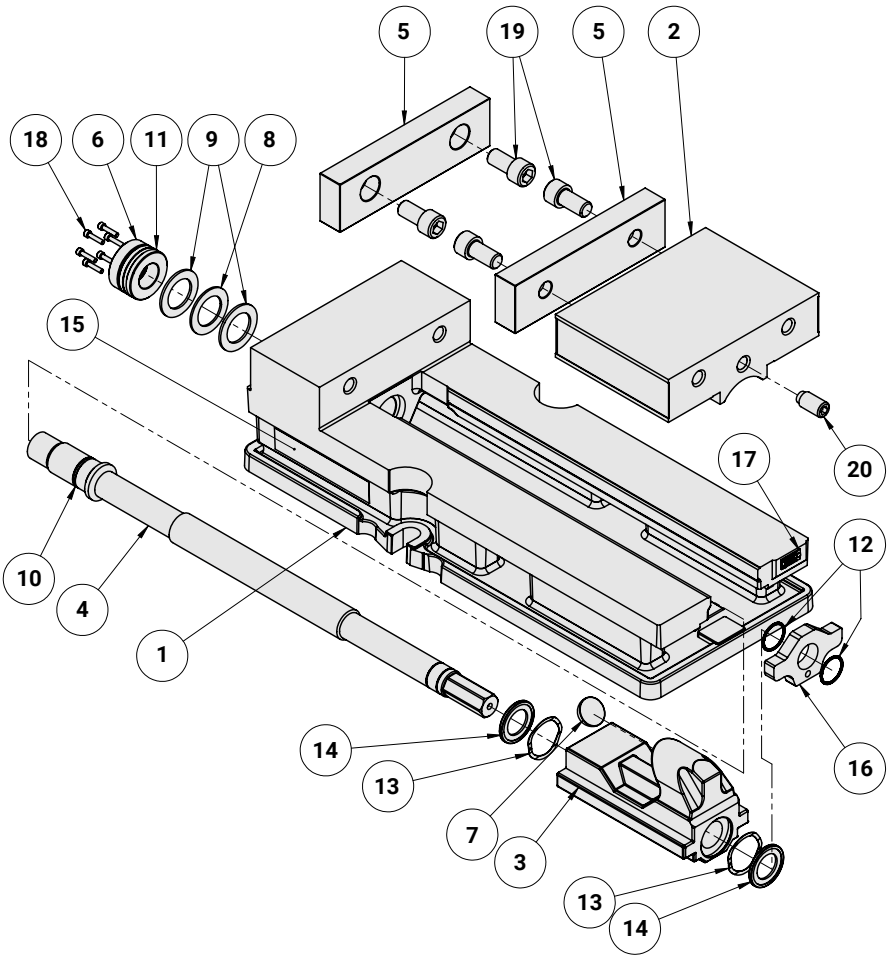

DX8R PARTS LIST

ITEM#	PART#	DESCRIPTION	QTY.
1	DX8-1	Body	1
2	DX8-2	Movable Jaw	1
3	DX8R-3	Nut	1
4	3810V-5A	Screw	1
5	D80-7	Jaw Plate	1
6	3800V-8	2-piece Retaining Nut	1
7	D80-9	Segment	1
8*	3800V-41	Thrust Bearing	1
9*	3800V-42	Thrust Bearing Washer	2
10*	3800V-99	O-ring #121	1
12*	3800V-128	O-ring #224	1
13*	DX8-169	Wave Spring	2
14*	PT800-211	Internal Brush Seal	2
15	DX8-223	Sticker, Body	2
17	DX8R-102	Model Tag	1
18	00-1197	SHCS 8-32 X 0.75 Lg	6
19	00-1481	SHCS 5/8-11 X 1.25 Lg	4
20	01-3953	CHDOG SHSS 5/8-11 X 1.25 Lg (not shown)	1
21	07-0230	U-Type Drive Screw (not shown)	2
22**	D80XL-248	Chip Guard (not shown)	1
23	D80I-10-SA	Handle Assembly (not shown)	1
24	3800V-111	Kurt Logo Tag (not shown)	2
Kurt's Repair Kit DX8-KIT, Includes the Following Parts:		D80-41, 3800V-42 (QTY-2), 3800V-99, PT800-211 (QTY-2), 3800V-147, DX8-169 (QTY-2)	
* Indicates Part is included in the DX8-KIT			
** Chip guard not included – available as an accessory at www.kurtworkholding.com .			

DX8R MECHANICAL DRAWING

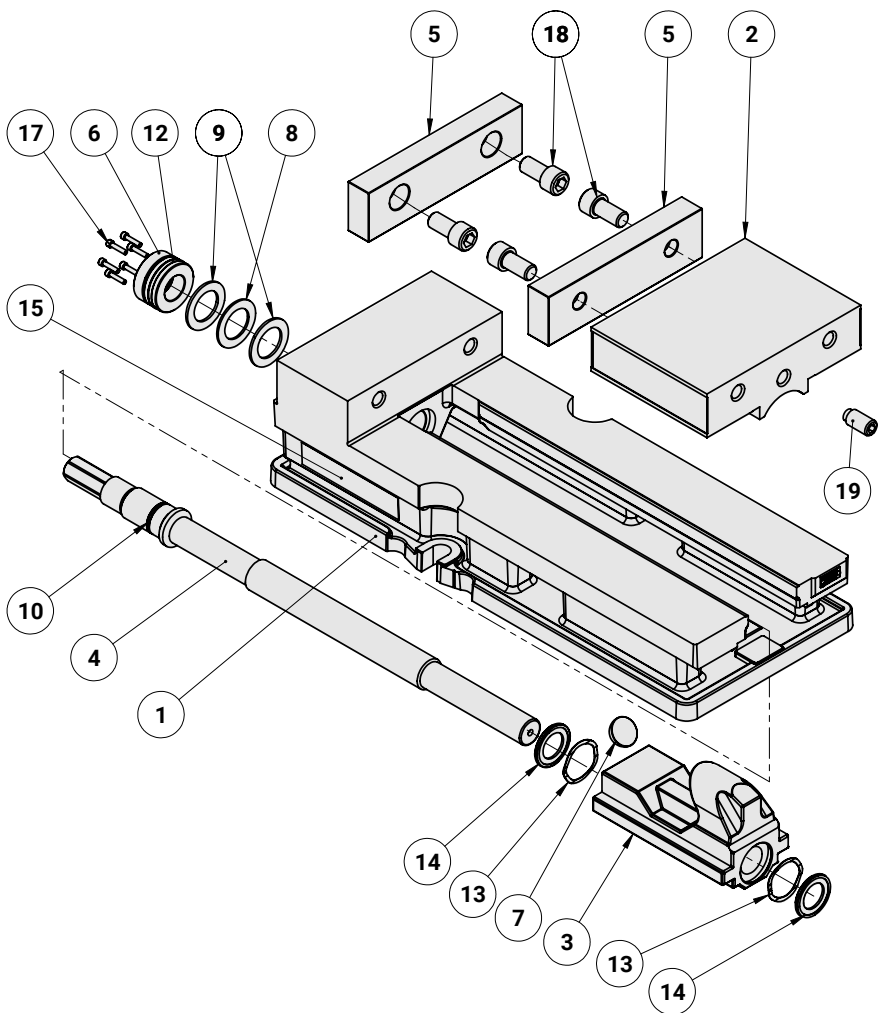

MAINTENANCE SCHEDULE

It is very important to perform regular maintenance on your Kurt vise to ensure proper operation. Improper maintenance will result in poor vise performance and may void your warranty.

Daily/ Weekly

1. Remove chips from surface of vise.
2. Visually inspect seals for damage and cleanliness.
3. Visually inspect for chip entrapments and remove when necessary.
4. Air-dry and apply rust inhibiting oil to the machined surface of the vise.

Monthly

1. Open the vise to the maximum opening.
2. In the back of the movable jaw (handle end, center hole) loosen the socket head set screw (approx. 6 turns). With the hex key (Allen wrench) in the set-screw socket, lift up and forward to pivot the Jaw off of the vise bed.
3. Slide the Jaw slightly toward the stationary jaw and lift up to remove the jaw from the "beak" of the nut.

Note: A spherical segment (shaped as 1/2 of a steel ball) is inside the cavity of the movable jaw and may fall out as the jaw is removed. Take care not to lose or misplace the spherical segment.

4. Turn the movable jaw over and clean the inside cavity. Also clean the spherical segment.
5. Remove chips, clean and apply a light coat of machine oil to the machined surface of the following item:
 - a. Nut & Screw assembly (clean exposed threads on the screw)
 - b. Bed of vise (top of "rails")
 - c. Inside of the vise between the center ways.
6. To re-assemble the movable jaw, apply a "glob" of grease to the under side of the movable jaw in the pocket. Place the spherical segment in the mating pocket and push into the grease. The grease will hold the segment in place when the jaw is turned over to replace.

MAINTENANCE SCHEDULE

- Tip the jaw so the front of the jaw (the side with the jaw plate) is on the vise bed. Lower the jaw on to the bed so that the segment contacts the hook part of the nut and rest the jaw on to the vise bed.
- Tighten the setscrew to firmly contact the nut. Back off the setscrew 1/4 turn (approx.).

Note: DO NOT leave the setscrew tightened firmly to the nut as this may cause improper operation. The movable jaw is designed to move slightly (pivot side to side) so maximum jaw plate contact is maintained when clamping out-of-parallel, sawed, or cast parts.

- Your vise is now ready for use. Open and close your vise to check for proper operation. Center the part to be clamped in the vise and close. Your parts should be centered from side to side to ensure proper clamping.

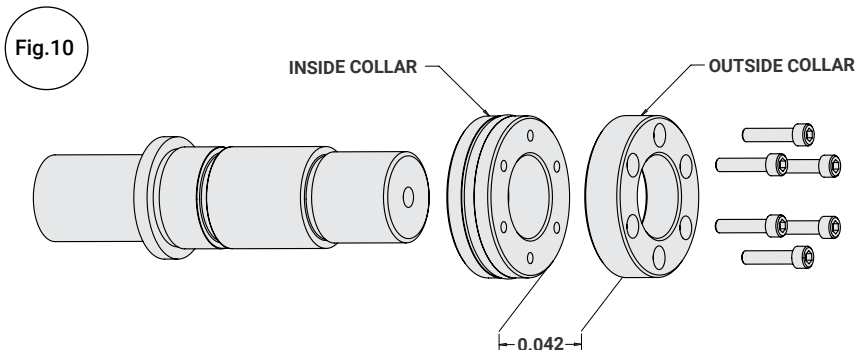
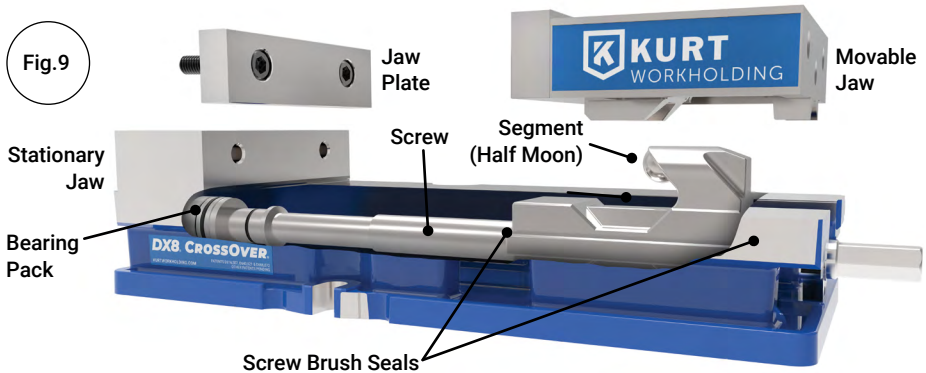

MAINTENANCE SCHEDULE

3 to 6 months

1. Open vise to maximum opening.
2. Loosen the set-screw and remove the movable jaw.
3. Remove spiral-retaining ring from handle end of the vise screw.
4. Remove the screw support from the vise body.
5. Remove the two-piece locking collar by removing the six SHCS.
6. With one screw still half-way out spin off the first collar.
7. Using a pin or screw reach into the second collar and spin it off to expose the bearings.
8. Remove the bearing assembly consisting of (2) thrust washers and (1)thrust bearing from the counter bore in the end of the body.
9. Clean and inspect the counter bore, thrust washers and thrust bearing.
10. Apply water-resistant grease to the thrust washer (i.e. marine grade grease)
11. Install thrust bearing pack on the screw in the reverse manner.
12. Install the first collar by threading the screw until it stops.
(See Fig.10 on page 17)
13. Install the second collar behind the first and thread on until it stops.
At this point the screw holes may or may not be lined up.
14. Turn the second collar counterclockwise until a hole lines up.
15. Then turn the collar back THREE (3) more screw holes. This will allow proper separation for the collar sections to lock on the threads and keep the bearings firmly in place. (See Fig.10)
16. Install the six SHCS and tighten in a star pattern.
17. Install the screw support in the body on the screw (Hex end) and secure using the spiral retaining ring.
18. Your vise is now ready to use.

TROUBLESHOOTING TIPS

If properly maintained, The Kurt DX8 Series vise will operate trouble free for many years. In some cases, it will be necessary to troubleshoot. Use the information below to help in the process.

Problem: My vise turns hard.

Tip: As a new vise the brush seal could be stiff. Allow for break in of vise.

Tip: As a used vise, it could be filled with chips and threads could be jammed. Properly clean and grease vise.

Problem: My vise will not turn in either direction.

Tip: The vise is jammed with debris. Disassemble and clean as needed.

Problem: My vise won't hold tolerance.

Tip: You may be experiencing jaw lift from clamping too high or on one side of the jaw. Lower the part in the vise jaw and clamp more material.

Problem: My vise is stiff when clamping on a part or is difficult to back off a part.

Tip: The vise's thrust bearing pack may need to be replaced.

Problem: My vise is not clamping at a high clamping force.

Tip: The vise's thrust bearing pack may need to be replaced.

All Kurt Manufacturing Company industrial workholding products and parts with the exceptions noted below, are warranted against defects in material and workmanship for the life of the product or part. (The life of the product is defined as that point in time when such item no longer functions due to normal wear and tear.) Failure to properly maintain and/or properly operate the product or part that has been worn out, abused, heated, ground or otherwise altered, used for a purpose other than that for which it was intended, or used in a manner inconsistent with any instructions regarding its use. The sole obligation of Kurt Manufacturing Company, Inc. (Kurt) and the purchaser's **SOLE AND EXCLUSIVE REMEDY** hereunder, shall be limited to the replacement or repair of any Kurt product or part (by an authorized Kurt technician) which are returned to Kurt Manufacturing Company's place of business or any authorized service center, transportation, shipping and postal charges prepaid, and there determined by Kurt Manufacturing Company to be covered by the warranty contained herein.



THE LIMITED WARRANTY DESCRIBED HEREIN IS MADE EXPRESSLY IN LIEU OF ANY OTHER EXPRESSED OR IMPLIED WARRANTIES, INCLUDING ANY IMPLIED WARRANTY OF MERCHANTABILITY OR FITNESS FOR A PARTICULAR PURPOSE. KURT MANUFACTURING COMPANY IS NOT RESPONSIBLE FOR THE IMPROPER USE OF ITS PRODUCTS. KURT SHALL NOT BE LIABLE FOR ANY DIRECT, INDIRECT, INCIDENTAL SPECIAL OR CONSEQUENTIAL DAMAGES, INCLUDING BUT NOT LIMITED TO, LOSS OF USE, REVENUE OR PROFIT.

KURT ASSUMES NO LIABILITY FOR, AND MAKES NO WARRANTY REGARDING ANY PURCHASE ITEMS WHERE THE MANUFACTURER OF SUCH ITEM EXTENDS A SEPARATE WARRANTY.



KURT WORKHOLDING

Thank you for your
purchase! If you have any
feedback or questions
please contact us:

Kurt Industrial Products // A Division Of Kurt Manufacturing

9445 East River Road NW | Mpls, MN 55433
Phone 763-574-8309 | Toll Free 877-226-7823
Fax 763-574-8318 | Toll Free Fax 877-226-7823

kurtworkholding.com | workholding@kurt.com

Manual Revision:
05.16.2024