

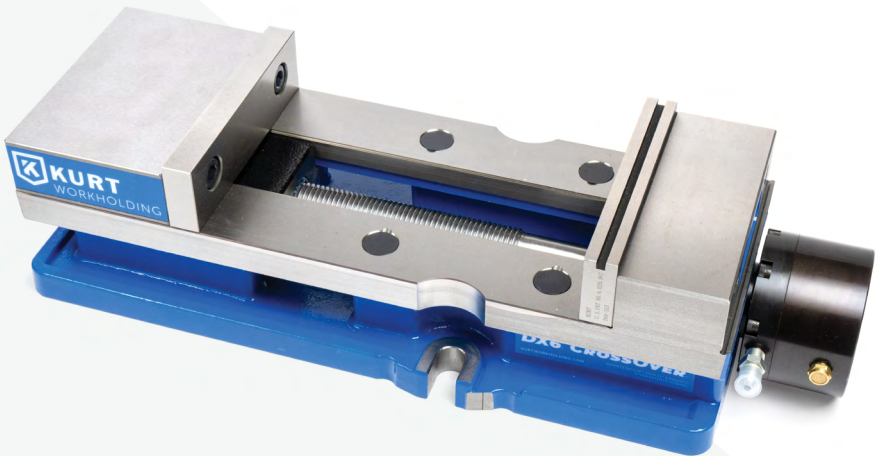

KURT WORKHOLDING

DX6H™ CROSSOVER™ ANGLOCK VISE HYDRAULIC VERSION

**Operating Instruction Manual
DX6H/DX6HR**



ENGLISH

TABLE OF CONTENTS

Introduction	3
Set-Up Instructions	4
Hydraulic Set-Up	5-9
Operating Instructions.....	10-15
DX6H Parts List	16
DX6H Mechanical Drawing	17
DX6HR Parts List.....	18
DX6HR Mechanical Drawing.....	19
KHU6 Mechanical Drawing	20
Maintenance Schedule.....	21-22
Hydraulic Unit Replacement Instructions.....	23-25
Troubleshooting Tips.....	25
Maintenance Log/Notes	26
Warranty.....	27

WISE DATA

Use this to fill out information about your vise for quick reference.

Purchase Date: _____ - _____ - _____

Purchase Order: _____

Purchased From: _____

Delivery Date: _____

Serial No.: _____

NOTE: MAKE SURE TO REGISTER YOUR WARRANTY ONLINE AT KURTHOLDING.COM

INTRODUCTION

Thank you for purchasing a Kurt DX6H. You have just purchased one of the best machine vises in the industry. The outstanding accuracy of this product is second to none. Backed by a lifetime warranty against workmanship and material defects, this product is built to last when used and maintained properly.

The original Kurt AngLock vises are designed for precision clamping on basic machine tools such as knee-type mills, and machining centers. They can be used for, but are not limited to, operations like precision boring, drilling, tapping, & finishing.

The patented AngLock design allows the movable jaw to advance in such a way that each pound of force forward induces a 1/2 pound of force downward which minimizes the jaw lift and increases accuracy. This, combined with the needle bearings, increases jaw clamping pressure. Other features include: 80,000 psi ductile iron body, hardened vise bed & jaw plates, and a semi- hard steel screw.

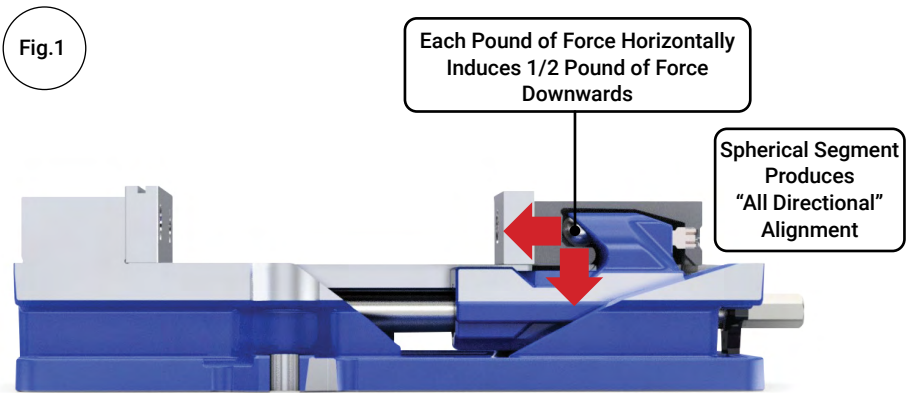

SET-UP INSTRUCTIONS

Now that you have your new Kurt Vise, it's time to set-up and begin using it. Your Kurt vise comes with a swivel handle in the shipping carton (instruction manual available online at www.kurtworkholding.com). The handle is specifically designed to provide maximum torque to your vise (clamping force provided below). Your vise should be mounted to a clean, flat surface. The surface and the vise must be free of any chips, dirt, or debris of any kind. The mounting surface can be honed if necessary. Clean the bottom of the vise with solvent or another cleaner if needed.

To minimize vise bed deflection, clamp your Kurt vise to your machine table, pallet, or sub-plate using the built-in clamping slots or through the body holes provided.

Additional clamping can be used, but may not be necessary. Please be sure to exercise good judgment when securing your vise to the mounting surface. Be sure your vise is secured and will not move when applying the machine pressure.

TORQUE/CLAMPING FORCE TABLES

MANUAL	
TORQUE FT-LBS	FORCE IN LBS.
10	500
20	1,450
30	2,450
40	3,450
50	4,400
60	5,400
70	6,350
80	7,350

HYDRAULIC	
HYDRAULIC PSI	FORCE IN LBS.
500	800
1,000	2,050
1,500	3,000
2,000	4,050
2,500	5,100
3,000	6,100
3,200	6,700

HYDRAULIC OPERATING INSTRUCTIONS

The DX6H can be operated hydraulically by hooking up the Kurt 6" Hydraulic Unit with a typical hydraulic pump or an air over hydraulic pump. Kurt offers several solutions for hydraulic pumps, one being the KHP3 air over hydraulic pump. Kurt offers other pump solutions and can be found on kurtworkholding.com.

The hydraulic unit (KHU6), on the end of the DX6H, has a 1/4 inch stroke. The KHU6 can be used in both single and double acting applications. For single acting, a spring will return the vise to the opened position when hydraulics are disengaged. If double acting is desired, both ports on the hydraulic unit will need to be hooked up to a pump (See Fig.2).



CAUTION

All NPT connections in hydraulic system must utilize pipe dope, not teflon tape. Teflon tape can get dislodged by fluid and end up in pump or unit, possibly voiding warranty.

Fig.2

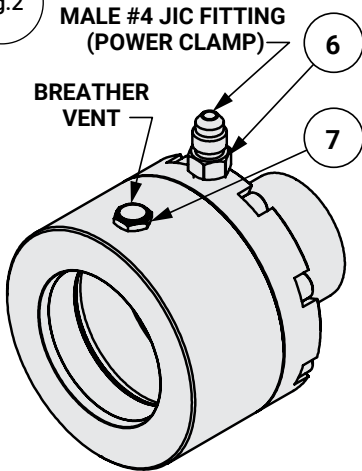

SINGLE ACTING FITTING PLACEMENT

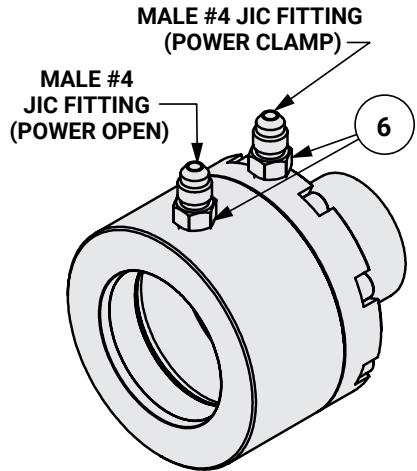

DOUBLE ACTING FITTING PLACEMENT

NOTE: A female #4 JIC fitting(s) is required at the end of the hydraulic line to mate up with the male #4 JIC fitting(s) on the hydraulic unit.

HYDRAULIC OPERATING INSTRUCTIONS

Basic Hydraulic Set-Up:

NOTE: The following set-up is specifically for the KHP3 pump

1. Remove plastic caps from pressure and release ports on Hydraulic pump. Install 90° fittings.
2. Remove plastic caps from pressure and release ports on hand or foot valve. Install straight fitting.
3. Install straight fitting on the Hydraulic Unit (1/8 NPTF) of the DX6H vise.
4. A filter-lubricator-regulator combination is recommended to insure clean air coming into the unit. See Clamping Force Chart for air pressure required to attain desired clamping force (pg. 5 & 9).
5. Connect the FRL to the input air port on the KHP3 hydraulic pump (See Fig.4)
6. Connect the hydraulic line to the hydraulic unit on the vise and then to the output side of the hydraulic pump (Fig.2 & 4)
7. If using a hand valve or foot valve, connect the 3-line color-coded airline cluster to the corresponding ports on the valve and pump (Fig.3 & 4).
8. Apply air pressure (80 PSI maximum) to system. Loosen swivel fitting at vise and bleed air. Tighten fitting. Release air pressure.
9. Repeat previous step until all air is purged
10. The KHP3 hydraulic pump will come pre-filled with oil (use #13 or DTE lite if needed)
11. System is now ready for use.

NOTE: For multiple vise hook-ups, call factory for recommendations

HYDRAULIC SET-UP

NOTE: The following set-up is specifically for the KHP3 pump.

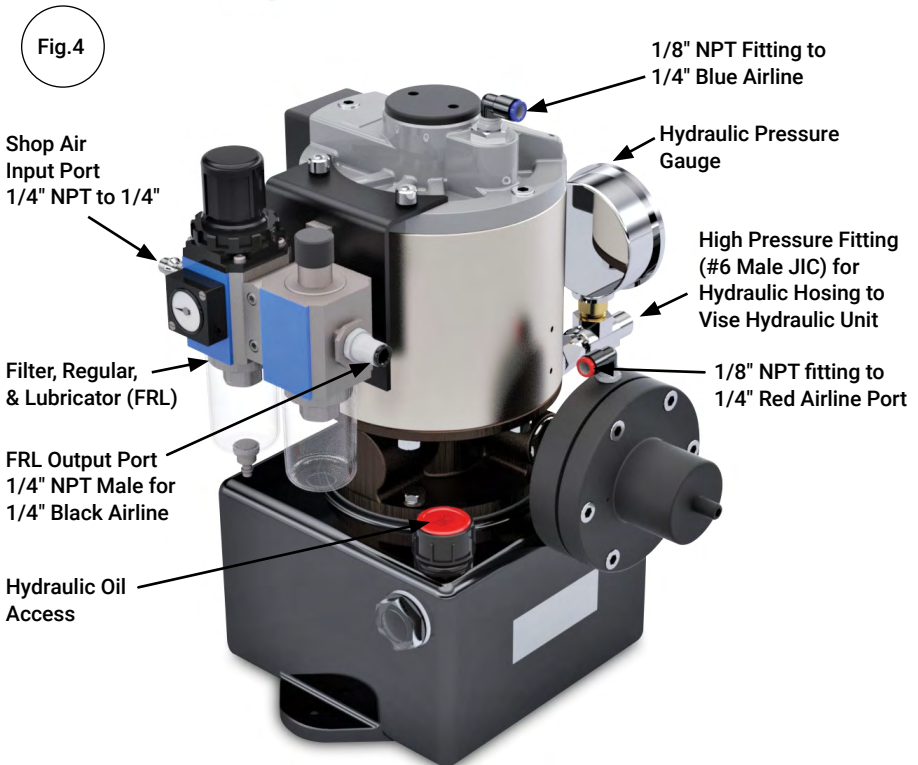
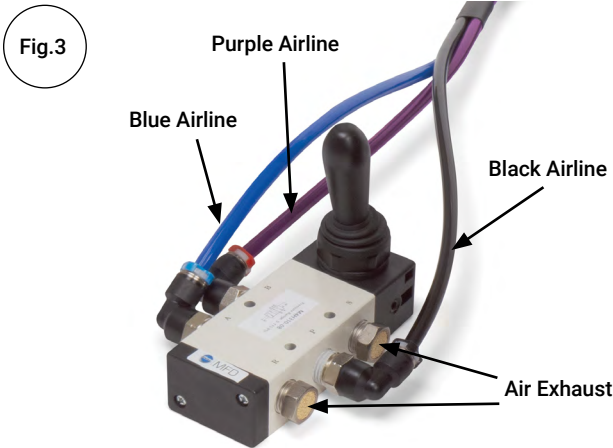

HYDRAULIC SET-UP

Fig.5

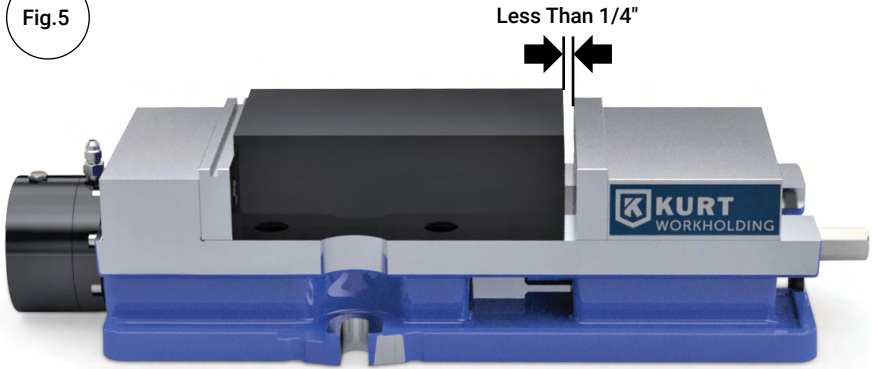

Jaw Positioning:

Once all plumbing is set up, it time to position jaws for hydraulic clamping.

1. Position jaws less than 1/4 inch from the part being clamped as is shown in Fig.5 above. This is done manually by putting the handle onto the hex end and turning the screw until the jaws are in position.
2. Make sure the jaws are less than 1/4 inch from the part since the hydraulic unit has only a 1/4 inch stroke.
3. The vise is now ready to have the hydraulics engaged for clamping the part.

HYDRAULIC OPERATING INSTRUCTIONS

Air Pressure Input to Hydraulic Pressure Output for Kurt Hydraulic Pump, KHP3

Fig.6

Flow and Pressure Performance Guides

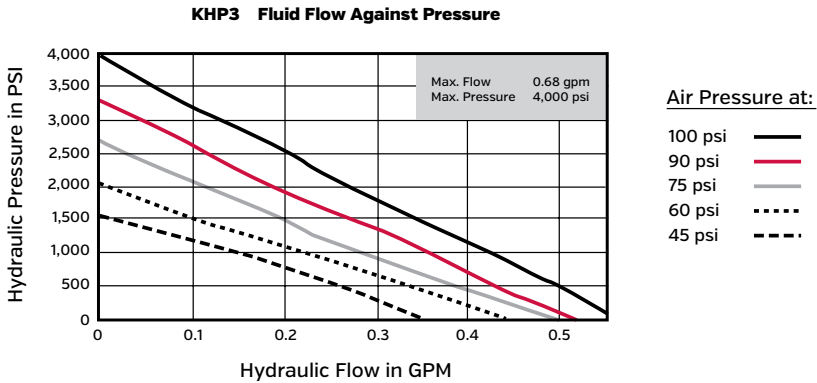

AIR PSI INPUT	OIL PSI OUTPUT
20	150
30	500
40	900
50	1,300
60	1,800
70	2,200
80	2,600
90	3,000
100	3,400

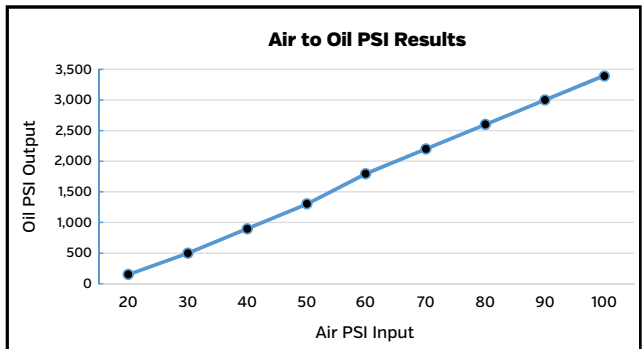

MANUAL OPERATING INSTRUCTIONS

For proper vise operation, insert the handle on to the hex end of the vise. Rotate clockwise to clamp and counterclockwise to unclamp your vise. This handle, combined with the correct amount of torque will provide you with all the clamping force you will need to machine your parts.

DO NOT use any other type of pressure to open or close your vise.

The uses of handle extensions, air impact wrenches, breaker bars, or hammer strikes are not recommended and will void the warranty if used. This will also cause damage to the thrust bearing and screw threads. If you need more clamping force, you may require a larger vise. A torque wrench may be used if set within the torque limits shown in the tables on page 4.

To properly clamp a part in your Kurt vise, you should place the part in the center of the jaws resting on the ways of the vise. Clamping only on one side or above the movable and stationary jaws, can result in jaw lift or loss of accuracy. (See Fig.7 on page 11)

If one-sided clamping is necessary, you **MUST** use a dummy part on the other side. When using parallels or step jaws, you must select a size that keeps the bottom of the clamped part at or below the top of the movable and stationary jaws. Always use jaw plates for clamping. If jaw plates are not used, damage to the mounting surface of the movable and stationary jaw will occur. This will result in reduced clamping accuracy and repeatability.

Fig.7

Sketch #2A

Incorrect part clamping.

Vise width centerline

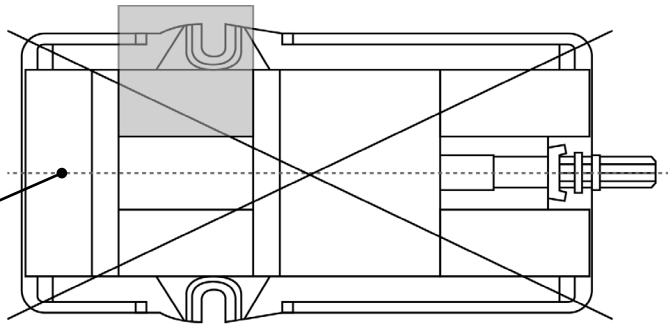

Sketch #2B

Correct part clamping

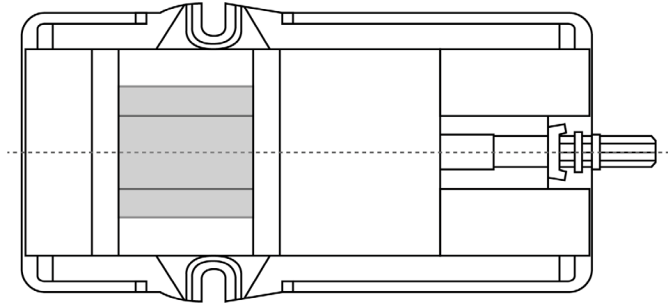

Sketch #2C

Correct part clamping

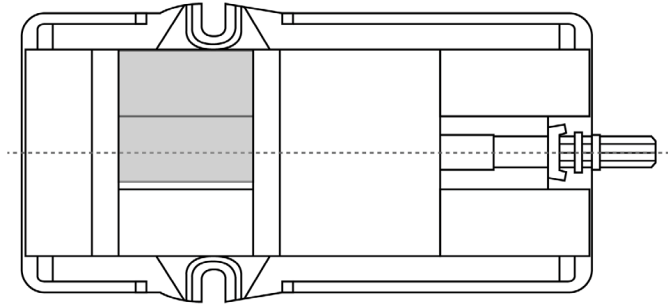

Sketch #2D

Correct part clamping

Dummy spacer

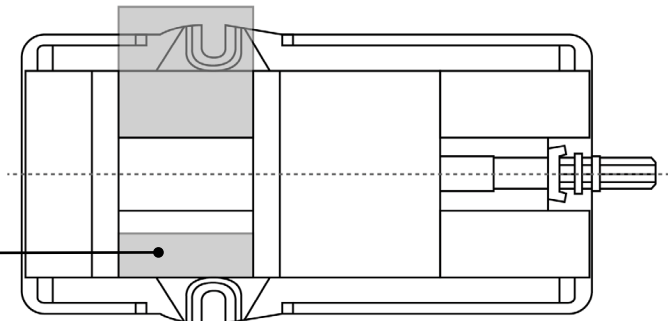

JAW POSITIONING

Fig.8

Note: Dimensions below are in inches unless specified.

AA	9.080
BB	12.120
CC	13.805
DD	16.842

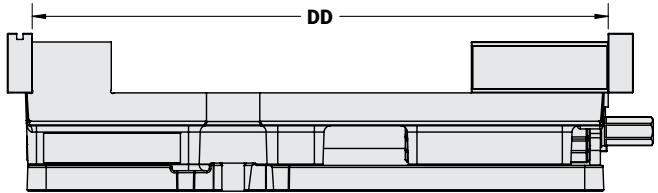
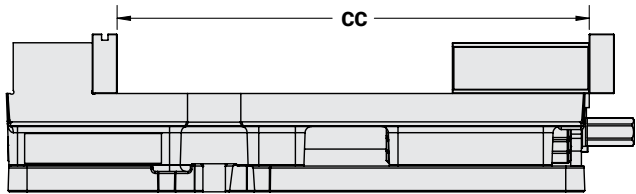
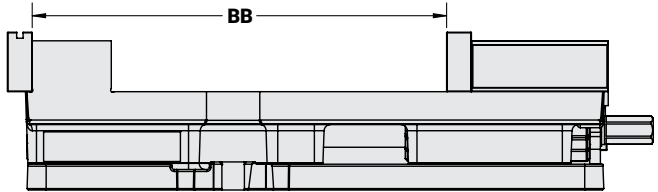
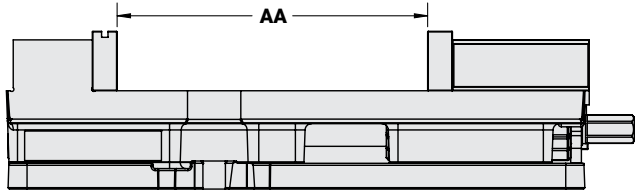

SIDE & END VIEW

Fig.9

Note: Dimensions below are in inches unless specified.

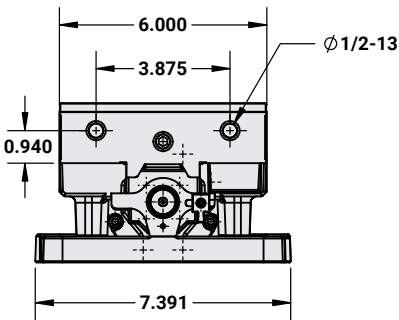
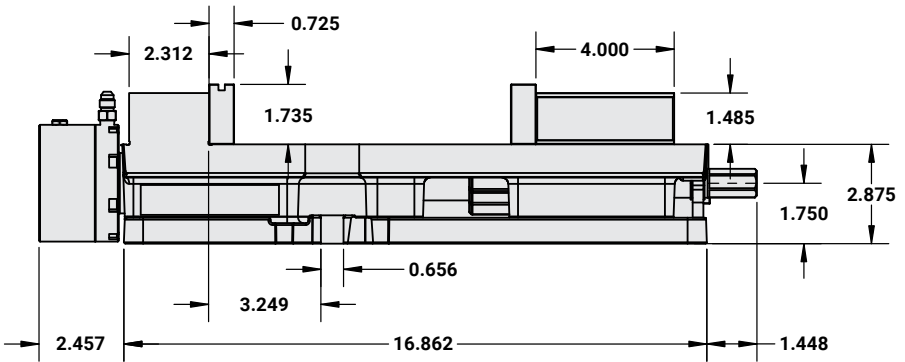

MOUNTING LOCATIONS

Note: Dimensions below are in inches unless specified.

Fig.10

M	0.328
Q	2.000
R	2.986
S	80 mm
T	200 mm
U	100 mm
V	10.000
W	4.000
X	16 mm
Y	0.625
Z	0.992
GG	3/4
HH	1.448
MM	25 mm
NN	0.531
QQ	2.03
RR	0.83

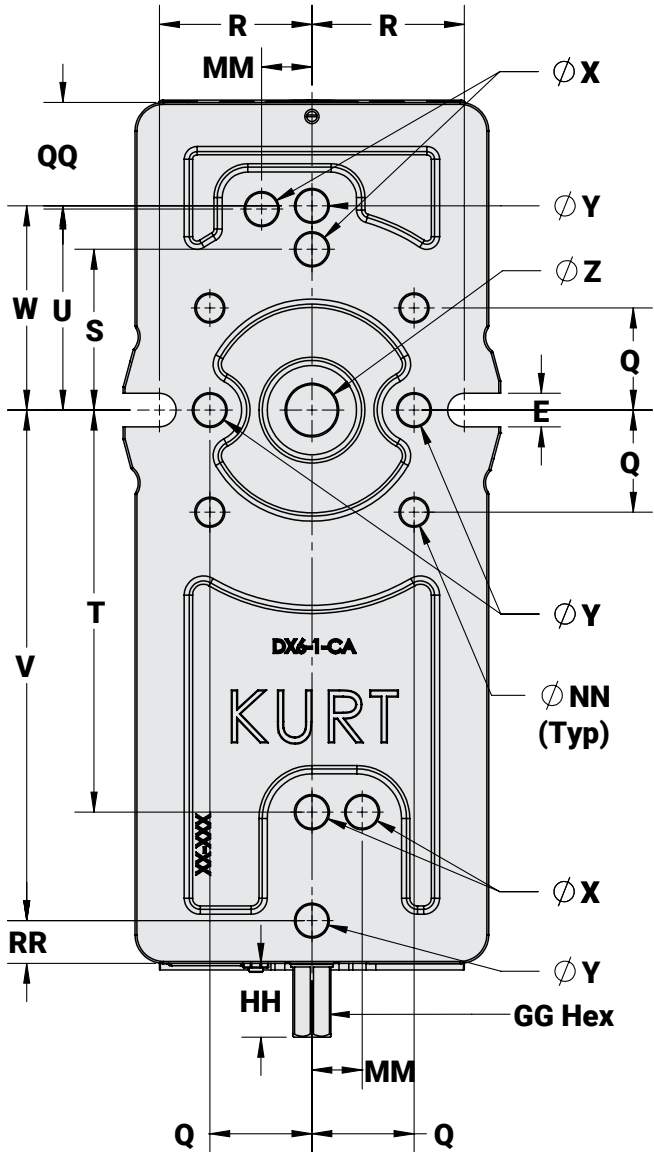

SURFACE MOUNT USING SINE KEYS

Mounting the new DX6H with keys requires the use of sine keys instead of standard keys. They are available in several different sizes that are listed on our website at www.kurtworkholding.com. The keys are sold in sets of 2 per package.

English Mounting:

The DX6H can be properly located using the four English sine key holes indicated by the Y's in Fig.10 on page 14. The DX6H vise can also be mounted using both bolt slots on the sides of the vise.

Metric Mounting:

The DX6H can be properly located using the two Metric sine key holes indicated by the X's in Fig.10.

PROPER CHIP GUARD* INSTALLATION AND USAGE

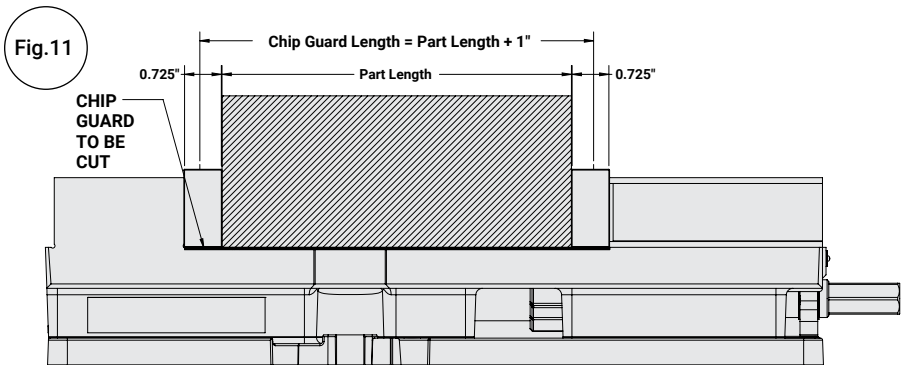

CAUTION

Chip Guard* stock shown above keep chips from the nut and screw assembly and must be cut and deburred to meet your application and safety needs.

Example: Part plus 1 inch = Length of Chip Guard.

NOTE: Remove Chip Guard stock. If left uncut, the excess material could cause injury.

*Chip guard not included – available as an accessory at www.kurtworkholding.com.

DX6H PARTS LIST

ITEM#	PART#	DESCRIPTION	QTY.
1	DX6-1 REV E	BODY, MACHINED	1
2	DX6-2	MOVABLE JAW, MACHINED	1
3	DX6-3	NUT, MACHINED	1
4	DX6H-5-CP	SCREW, HYDRAULIC	1
5	D60-7	JAW PLATE	1
6	3600V-8-P	2 PIECE RETAINING NUT	1
7	D60-9	SEGMENT	1
8	WSRL46-SA	WORK STOP	1
9	3600V-99	O-RING #117	1
10	DX6-111	KURT LOGO TAG	2
11	3600V-128	O-RING #129	1
12	3600V-147	RETAINING RING, SPIRAL	2
13	3600V-191-SA	PROTECTIVE PLUG ASSY	4
14	D688-211	INTERNAL BRUSH SEAL	2
15	DX6-223	MODEL TAG	2
16	DX6-224-CP	SCREW SUPPORT	1
17*	DL600-249	CHIP GUARD	1
18	DX6-169	WAVE SPRING	2
19	D60-315-P	GROOVED JAW PLATE	1
20	00-1191	SHCS 8-32 X 0.375 LG	4
21	00-1414	SHCS 1/2-13 X 0.75 LG	4
22	01-3134	SHSS 1/2-13 X 0.625 LG	1
23	KHU6	KURT HYDRAULIC UNIT 6"	1
24	01-3278	SHSS CONE PT 1/4-20 X 0.75 LG	1
25	D80-41	THRUST BEARING	1
26	3600V-42	THRUST WASHER	2

*Chip guard not included – available as an accessory at www.kurtworkholding.com.

DX6H MECHANICAL DRAWING

Fig.12

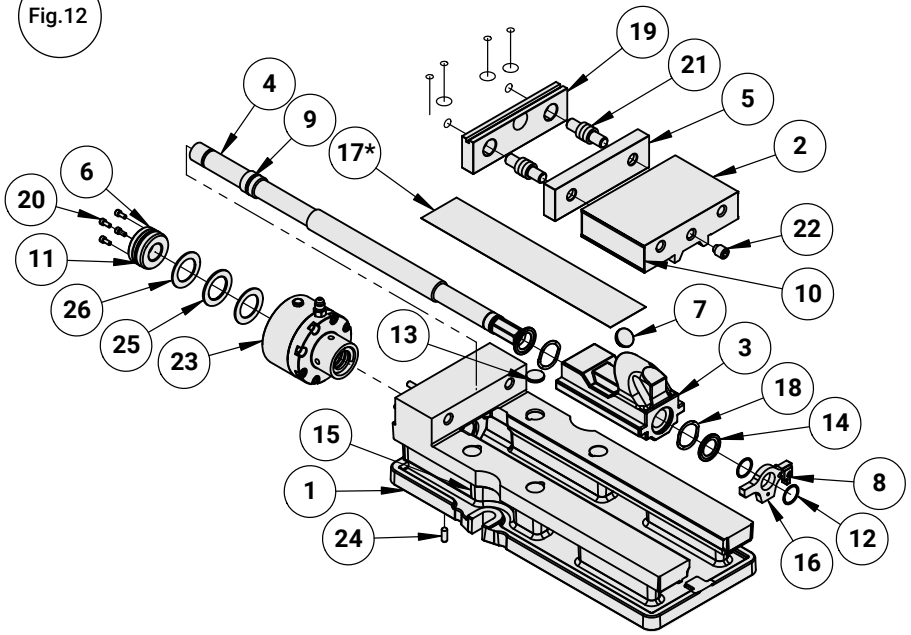

*Chip guard not included – available as an accessory at www.kurtworkholding.com.

DX6HR PARTS LIST

ITEM#	PART#	DESCRIPTION	QTY.
1	DX6-1	REV E BODY, MACHINED	1
2	DX6-2	MOVABLE JAW, MACHINED	1
3	DX6R-3	NUT, MACHINED REVERSED	1
4	DX6HR-5-CP	SCREW, HYDRAULIC REVERSE	1
5	D60-7	JAW PLATE	1
6	3610V-8	2 PIECE RETAINING NUT, REVERSE	1
7	D60-9	SEGMENT	1
8	WSRL46-SA	WORK STOP	1
9	3600V-99	O-RING #117	1
10	DX6-111	KURT LOGO TAG	2
11	3600V-128	O-RING #129	1
12	3600V-191-SA	PROTECTIVE PLUG ASSY	4
13	D688-211	INTERNAL BRUSH SEAL	2
14	DX6-223	MODEL TAG	2
15*	DL600-249	CHIP GUARD, 12 X 2.25 X 0.015	1
16	DX6-169	WAVE SPRING	2
17	D60-315-P	GROOVED JAW PLATE	1
18	00-1191	SHCS 8-32 X 0.375 LG	4
19	00-1414	SHCS 1/2-13 X 0.75 LG	4
20	01-3134	SHSS1/2-13 X 5/8 LG	1
21	KHU6	KURT HYDRAULIC UNIT 6"	1
22	01-3278	SHSS CONE PT 1/4-20 X 0.75 LG	1
23	D80-41	THRUST BEARING	1
24	3600V-42	THRUST WASHER	2

*Chip guard not included – available as an accessory at www.kurtworkholding.com.

KHU6 MECHANICAL DRAWING

Fig.12

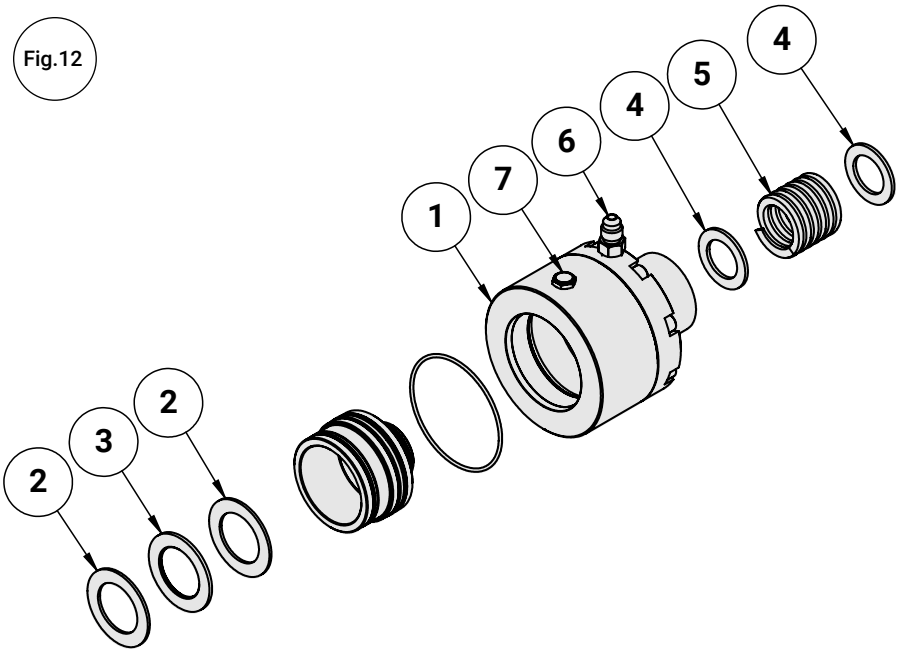

ITEM#	PART#	DESCRIPTION	QTY.
1	KHU6	HYDRAULIC UNIT 6"	1
2	3600V-42	THRUST WASHER	2
3	D80-41	THRUST BEARING	1
4	360HU-230	WASHER	2
5	360HU-87A	SPRING, COMPRESSION	1
6	2404-04-02	FITTING, 4MJ-2MP	2
7	PCFBR-02	1/8" NPT BREATHER	1

MAINTENANCE SCHEDULE

It is very important to perform regular maintenance on your Kurt vise to ensure proper operation. Improper maintenance will result in poor vise performance and may void your warranty.

Daily/ Weekly

1. Remove chips from surface of vise.
2. Visually inspect seals for damage and cleanliness.
3. Visually inspect for chip entrapments and remove when necessary.
4. Air-dry and apply rust inhibiting oil to the machined surface of the vise.

Monthly

1. Open the vise to the maximum opening.
2. In the back of the movable jaw (handle end, center hole) loosen the socket head set screw (approx. 6 turns). With the hex key (Allen wrench) in the set-screw socket, lift up and forward to pivot the Jaw off of the vise bed.
3. Slide the Jaw slightly toward the stationary jaw and lift up to remove the jaw from the “beak” of the nut.
Note: A spherical segment (shaped as 1/2 of a steel ball) is inside the cavity of the movable jaw and may fall out as the jaw is removed. Take care not to lose or misplace the spherical segment.
4. Turn the movable jaw over and clean the inside cavity. Also clean the spherical segment.
5. Remove chips, clean and apply a light coat of machine oil to the machined surface of the following item:
 - a. Nut & Screw assembly (clean exposed threads on the screw)
 - b. Bed of vise (top of “rails”)
 - c. Inside of the vise between the center ways.
6. To re-assemble the movable jaw, apply a “glob” of grease to the under side of the movable jaw in the pocket. Place the spherical segment in the mating pocket and push into the grease. The grease will hold the segment in place when the jaw is turned over to replace.

7. Tip the jaw so the front of the jaw (the side with the jaw plate) is on the vise bed. Lower the jaw on to the bed so that the segment contacts the hook part of the nut and rest the jaw on to the vise bed.
8. Tighten the setscrew to firmly contact the nut. Back off the setscrew 1/4 turn (approx.).

Note: DO NOT leave the setscrew tightened firmly to the nut as this may cause improper operation. The movable jaw is designed to move slightly (pivot side to side) so maximum jaw plate contact is maintained when clamping out-of-parallel, sawed, or cast parts.

9. Your vise is now ready for use. Open and close your vise to check for proper operation. Center the part to be clamped in the vise and close. Your parts should be centered from side to side to ensure proper clamping.

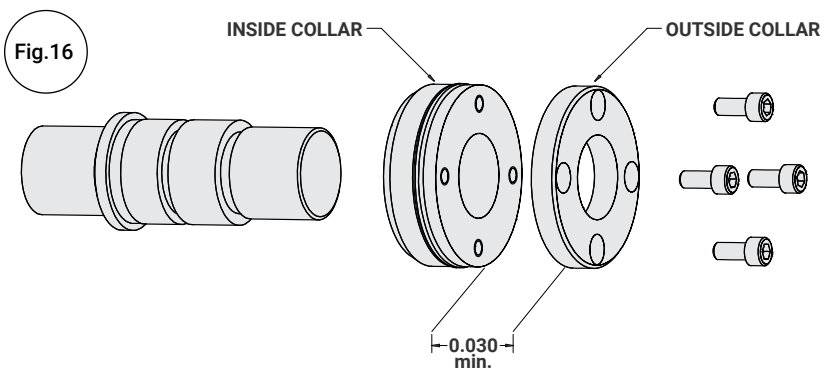
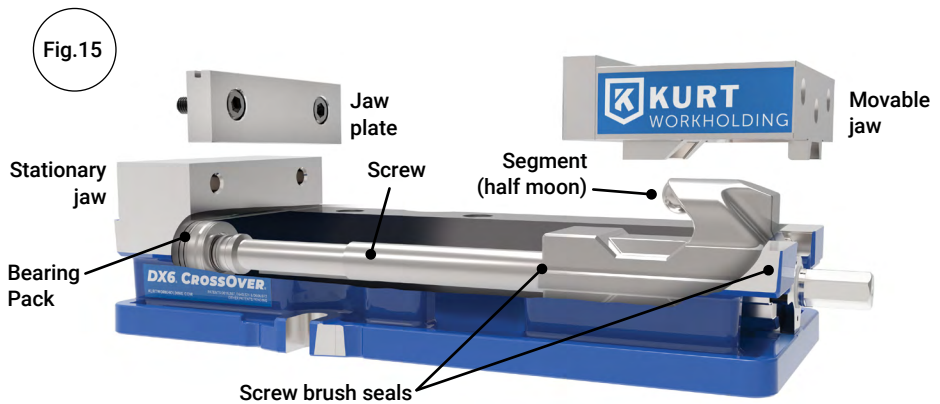

HYDRAULIC UNIT REPLACEMENT INSTRUCTIONS

REMOVING YOUR OLD UNIT:

1. Remove 4 SHCS of 2 piece retaining nut. Remove the first (smaller) retaining nut.
2. Remove set screw from bottom of vise. This will release the nut/screw assembly from the vise, but still have the screw connected to the hydraulic unit. Slide hydraulic unit slightly out of the counter bore of the vise body.
3. Install 2 SHCS removed in Step 1 opposite one another, threading them approximately halfway in. Using the two SHCS as a sort of handle (or use Kurt Spanner Wrench P/N: DL640-307A-SA), loosen the second (larger) portion of the retaining nut. You should notice a washer and spring coming out of the end of the hydraulic unit.
4. Fully Remove the second (larger) portion of the 2 piece retaining nut. Slide hydraulic unit off of screw. You may leave the washer/spring/washer on the screw, or replace them with new (if available).

INSTALLING NEW UNIT:

1. Install the washer/spring/washer assembly on screw. Slide new hydraulic unit onto screw. Ensure the new hydraulic unit has the washer/bearing/washer installed on the side which the 2 piece retaining nut will be installed. (See Fig.17)

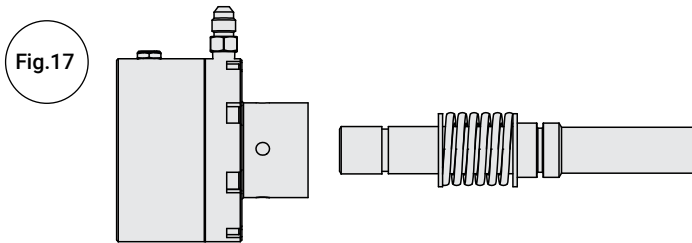

2. Using the larger portion of the 2 piece retaining nut and partially screwed in SHCS as a sort of handle (or Using Kurt Spanner Wrench P/N: DL640-307A-SA), tighten the 2 piece retaining nut, which will compress the spring. (See Fig.18)

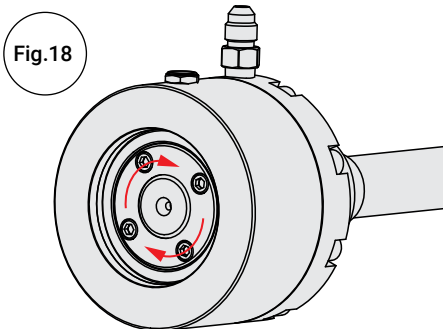

3. Continue to do so until the washer is slightly recessed inside the hydraulic unit. This is crucial, otherwise the spring will keep the hydraulic unit from completely bottoming out in the vise body counter bore. (See Fig.19)

Fig.19

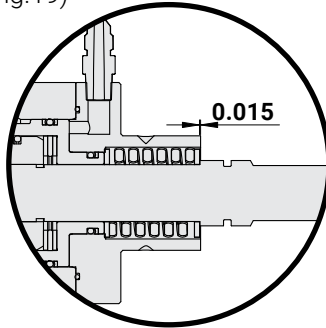

4. Slide hydraulic unit into counter bore on vise body. Tighten the set screw located on the bottom side of the body while slightly rotating the hydraulic unit back and forth approximately 30 degrees total, this will ensure the set screw seats properly in the machined divot on the hydraulic unit. You should feel the amount you can rotate the unit slowly diminish until it is rigid and the set screw is tight. Hand tight is sufficient. (See Fig.20)

Fig.20

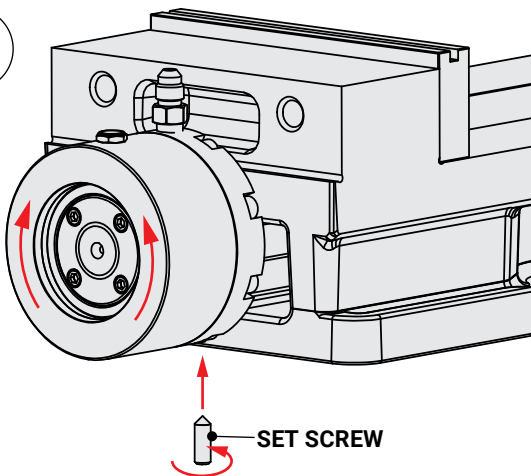

5. Loosen the larger portion of the 2 piece retaining nut several turns, and then tighten to just snug, then back off a quarter turn. This allows the spring force to be held between the vise body and hydraulic unit only, not on the shoulder of the screw. This also allows the screw turn freely on the bearings. Remove SHCS's.

6. Install the smaller portion of the 2 piece retaining nut until it touches the larger portion, then back it off to align it with the nearest screw holes. Then, turn it an additional half turn, or 2 screw holes. The gap between the 2 pieces is crucial.
7. Hand tighten the SHCS in a star pattern, using an Allen wrench, until they are tight. Vise handle should turn smoothly. If there is resistance: remove SHCS, remove smaller portion of 2 piece retaining ring and repeat steps 5 through 7.

TROUBLESHOOTING TIPS

If properly maintained, the Kurt DX6 Series vise will operate trouble free for many years. In some cases it will be necessary to troubleshoot. Use the information below to help in the process.

Problem: My vise turns hard.

Tip: As a new vise the brush seal could be stiff. Allow for break-in of vise.

Tip: As a used vise, it could be filled with chips and threads could be jammed. Properly clean and grease vise.

Problem: My vise will not turn in either direction.

Tip: The vise is jammed with debris. Disassemble and clean as needed.

Problem: My vise won't hold tolerance.

Tip: You may be experiencing jaw lift from clamping too high or on one side of the jaw. Lower the part in the vise jaw and clamp more material.

Problem: My vise is stiff when clamping on a part or is difficult to back off a part.

Tip: The vise's thrust bearing pack may need to be replaced.

Problem: My vise is not clamping at a high clamping force.

Tip: The vise's thrust bearing pack may need to be replaced.

All Kurt Manufacturing Company industrial workholding products and parts with the exceptions noted below, are warranted against defects in material and workmanship for the life of the product or part. (The life of the product is defined as that point in time when such item no longer functions due to normal wear and tear.) Failure to properly maintain and/or properly operate the product or part that has been worn out, abused, heated, ground or otherwise altered, used for a purpose other than that for which it was intended, or used in a manner inconsistent with any instructions regarding its use. The sole obligation of Kurt Manufacturing Company, Inc. (Kurt) and the purchaser's **SOLE AND EXCLUSIVE REMEDY** hereunder, shall be limited to the replacement or repair of any Kurt product or part (by an authorized Kurt technician) which are returned to Kurt Manufacturing Company's place of business or any authorized service center, transportation, shipping and postal charges prepaid, and there determined by Kurt Manufacturing Company to be covered by the warranty contained herein.



THE LIMITED WARRANTY DESCRIBED HEREIN IS MADE EXPRESSLY IN LIEU OF ANY OTHER EXPRESSED OR IMPLIED WARRANTIES, INCLUDING ANY IMPLIED WARRANTY OF MERCHANTABILITY OR FITNESS FOR A PARTICULAR PURPOSE. KURT MANUFACTURING COMPANY IS NOT RESPONSIBLE FOR THE IMPROPER USE OF ITS PRODUCTS. KURT SHALL NOT BE LIABLE FOR ANY DIRECT, INDIRECT, INCIDENTAL SPECIAL OR CONSEQUENTIAL DAMAGES, INCLUDING BUT NOT LIMITED TO, LOSS OF USE, REVENUE OR PROFIT.

KURT ASSUMES NO LIABILITY FOR, AND MAKES NO WARRANTY REGARDING ANY PURCHASE ITEMS WHERE THE MANUFACTURER OF SUCH ITEM EXTENDS A SEPARATE WARRANTY.



KURT WORKHOLDING

Thank you for your
purchase! If you have any
feedback or questions
please contact us:

Kurt Industrial Products // A Division Of Kurt Manufacturing

9445 East River Road NW | Mpls, MN 55433
Phone 763-574-8309 | Toll Free 877-226-7823
Fax 763-574-8318 | Toll Free Fax 877-226-7823

kurtworkholding.com | workholding@kurt.com

Manual Revision:
06.07.2024