



WISE FEATURES

- » High clamp force
- » Jaw design minimizes jaw lift
- » Easy center-line adjustment
- » Quick lash adjustment
- » Hex on both ends of screw, can be adjusted from either side
- » 52mm pattern spacing for pull-stud mounting systems
- » End-effector ready for automation integration
- » Max torque 45 foot pounds

Precision Force 5-axis vises feature robot-ready design Kurt AngLock® tech for maximum workholding strength, and zero-point quick-release pallets.

Kurt's PF 5-Axis vise lineup features 3 models with 3 available jaw options. The PF420, PF440 and PF460 vises come with a standard 4-inch jaw width and jaw openings ranging from 2.625 to 6.625 inches. Patented AngLock® design pushes vise jaws down and forward for greater surface contact on parts—maximizing holding strength with less clamp force.

The Robot-ready PF-series vise design offer user-friendly features including easy-to-adjust lash and 52 mm spacing for pull-stud mounting systems. New Quick Centerline Adjustment is accessed from the top of the vise and allows fast and efficient adjustments to keep parts perfectly positioned without removing the vise from a machine. Spring-loaded gibs keep parts square and maximize part-positioning repeatability through multiple cycles.



Dovetail

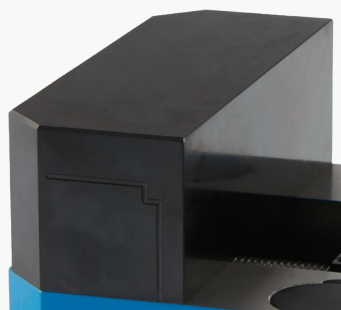

Machinable



Serrated

JAW FEATURES

- » Movable jaw options: Machinable, Dovetail and Serrated
- » Jaws and nuts can be reversed for ID clamping
- » Nuts are gibbed to help with squareness

Kurt PF 5-Axis Vises

TECHNICAL SPECIFICATIONS

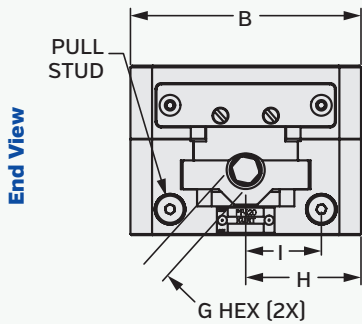
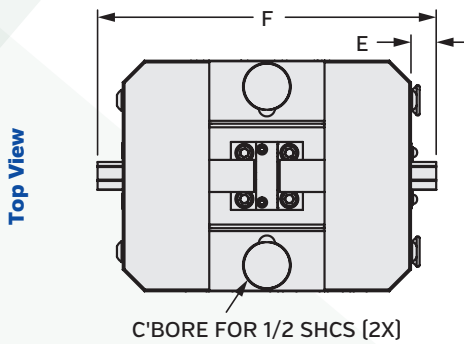
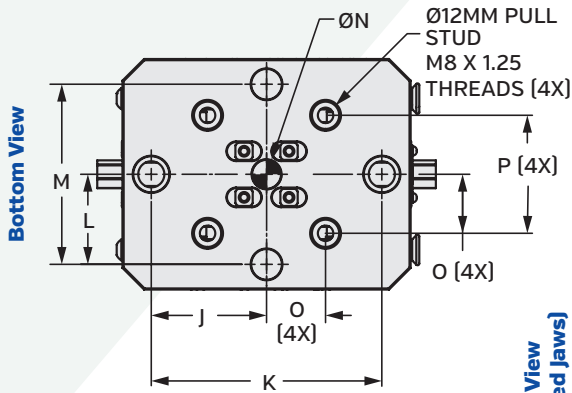

Torque (ft-lbs)	Clamp Force (lbs)
10	600
20	1,200
30	1,900
40	2,500
45	3,300

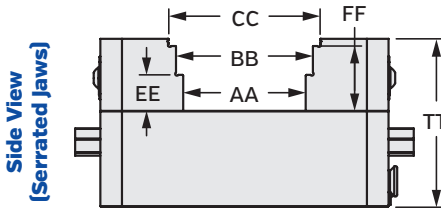

**Serrated models:
PF420S, PF440S, PF460S**

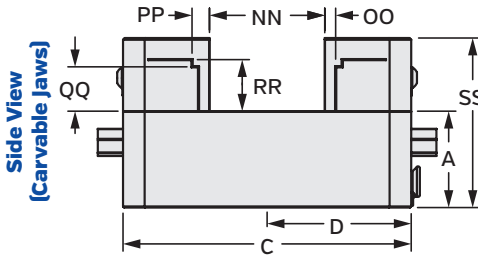

**Carvable models:
PF420C, PF440C, PF460C**

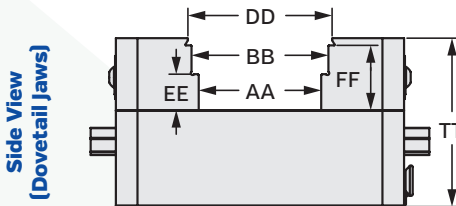

**Dovetail models:
PF420D, PF440D, PF460D**

	PF420	PF440	PF460
A	1.672	1.672	1.672
B	4.000	4.000	4.000
C	5.000	7.000	9.000
D	2.500	3.500	4.500
E	0.438	0.438	0.438
F	5.875	7.875	9.875
G	7/16	7/16	7/16
H	2.000	2.000	2.000
I	1.313	1.313	1.313
J	2.000	2.000	2.000
K	4.000	4.000	4.000
L	1.563	1.563	1.563
M	3.125	3.125	3.125
N	0.500	0.500	0.500
O	1.024	1.024	1.024
P	52mm	52mm	52mm
AA	2.125	4.125	6.125
BB	2.375	4.375	6.375
CC	2.625	4.625	6.625
DD	2.501	4.50	6.501
EE	0.625	0.625	0.625
FF	1.125	1.125	1.125
NN	2.000	4.000	6.000
OO	0.190	0.190	0.190
PP	0.303	0.303	0.303
QQ	0.770	0.770	0.770
RR	0.885	0.885	0.885
SS	2.942	2.942	2.942
TT	2.922	2.922	2.922

Kurt 5-Axis Workholding Zero Point Pallets

Kurt's new 52 mm zero-point quick-release pallet system is designed for use with PF-Series 5-Axis Vises. 52 mm spacing is compatible with other vise brands.



kurtworkholding.com



Kurt Manufacturing // A Full-Service Multi-Divisional Manufacturer since 1946

9445 East River Road NW | Minneapolis, MN 55433 | workholding@kurt.com | 877.226.7823