

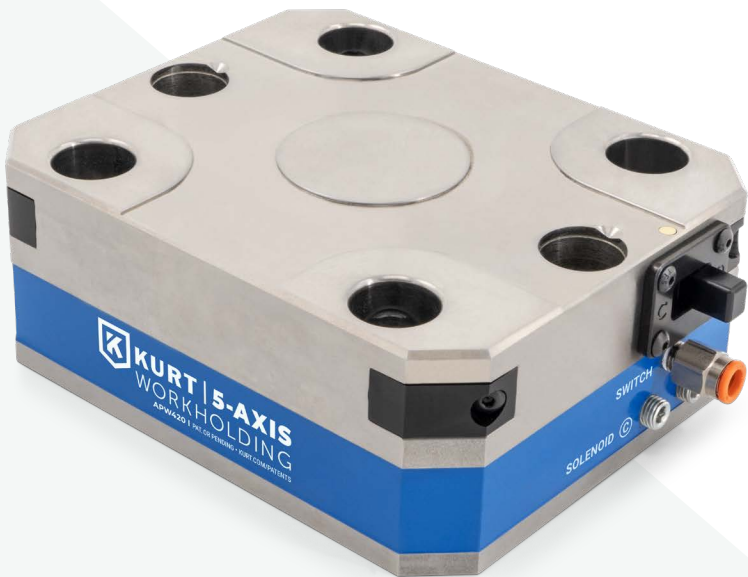

KURT WORKHOLDING

APW420 AIR PALLET

Operating Instruction Manual



ENGLISH

TABLE OF CONTENTS

Pneumatic Set-Up 3

Installation & Mounting Guide 4

Side & End View 5

Maintenance Schedule..... 6

Warranty..... 7



New Kurt PFW420 5-Axis Vise mounted on an APW420 Air Pallet

PNEUMATIC OPERATING INSTRUCTIONS

To plumb unit to run with manual operated switch: plumb shop air to switch using 1/4" tube in push to connect fittings. Assure the solenoid ports labeled C and O are plugged with pipe plugs.

To plumb unit to run with air solenoid: plumb clamp port "C" with 1/4" tube from solenoid, plumb open/unclamp port "O" with 1/4" tube from solenoid. Assure the switch port "SWITCH" is plugged with pipe plug.

Note: The unit comes ready to run with the manual switch. In the event you want to use solenoid valves the manual switch must be set to the center position as seen in Fig.1 below.



CAUTION

All NPT connections in pneumatic system must utilize pipe dope, not Teflon tape. Teflon tape can get dislodged and end up in unit, possibly voiding warranty.

Fig.1

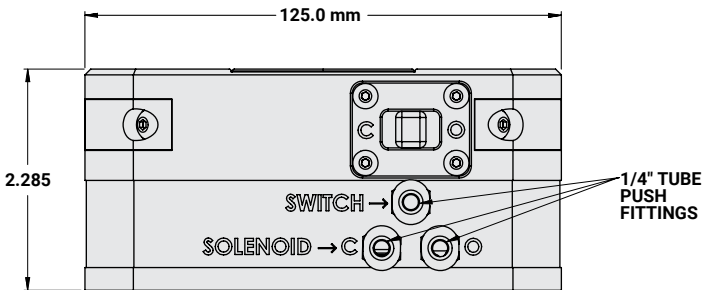

INSTALLATION & MOUNTING

All of the vises in the PFW Series can be mounted with 1/2 inch SHCS using the counter-bored through holes in the center of the rails of the vise. Additional hole locations are shown below.

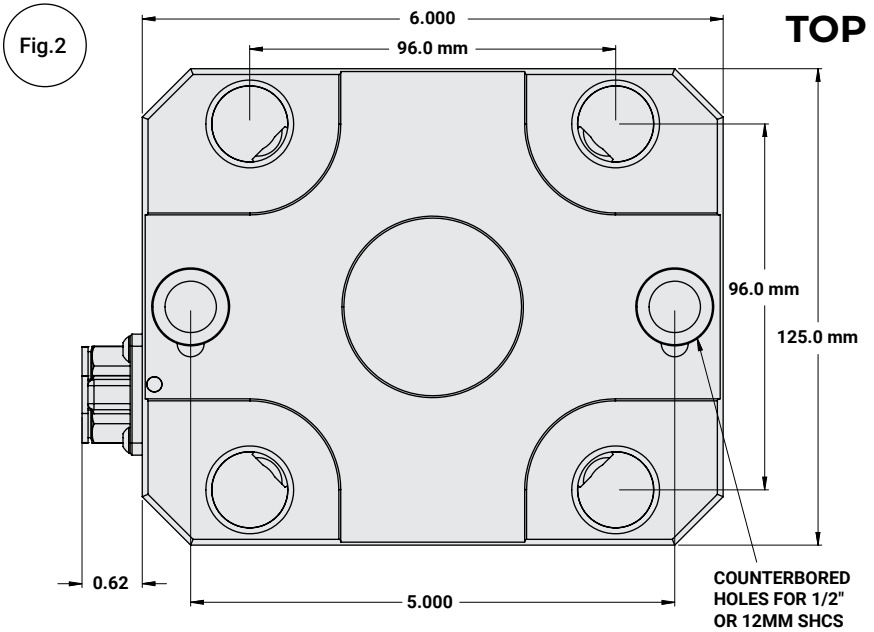

BOTTOM

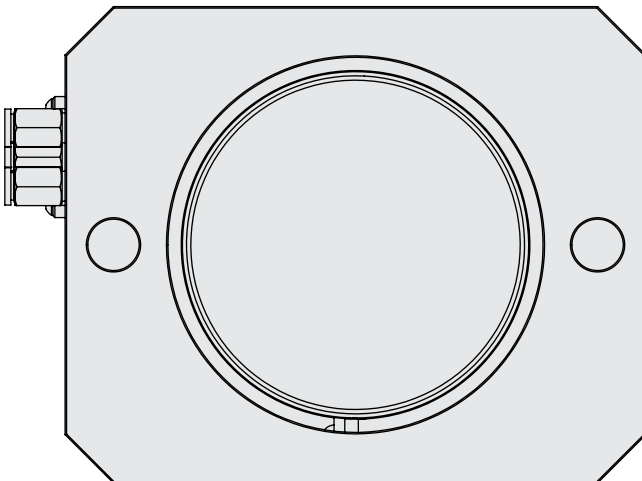
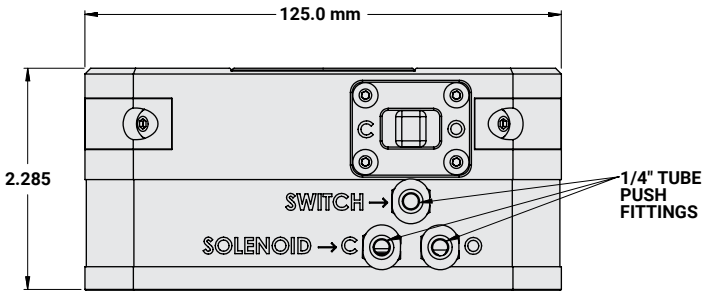
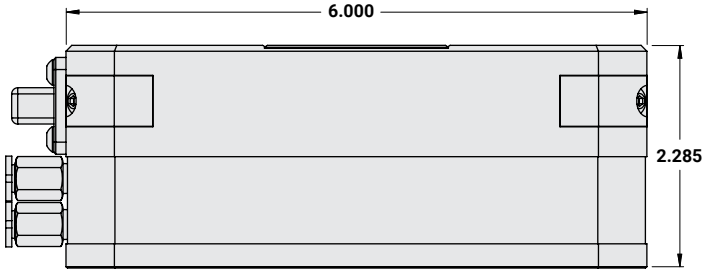

Fig.3

SIDE & END VIEW

Note: Dimensions below are in inches unless specified.



MAINTENANCE SCHEDULE

It is very important to perform regular maintenance on your Kurt vise to assure proper operation. Improper maintenance will result in poor vise performance and may void your warranty.

Daily/Weekly

1. Remove chips from surface of vise.
2. Visually inspect for chips and damage to the unit.
3. Air-dry and apply rust inhibiting oil to the machined surface of the vise.

All Kurt Manufacturing Company industrial workholding products and parts with the exceptions noted below, are warranted against defects in material and workmanship for the life of the product or part. (The life of the product is defined as that point in time when such item no longer functions due to normal wear and tear.) Failure to properly maintain and/or properly operate the product or part that has been worn out, abused, heated, ground or otherwise altered, used for a purpose other than that for which it was intended, or used in a manner inconsistent with any instructions regarding its use. The sole obligation of Kurt Manufacturing Company, Inc. (Kurt) and the purchaser's **SOLE AND EXCLUSIVE REMEDY** hereunder, shall be limited to the replacement or repair of any Kurt product or part (by an authorized Kurt technician) which are returned to Kurt Manufacturing Company's place of business or any authorized service center, transportation, shipping and postal charges prepaid, and there determined by Kurt Manufacturing Company to be covered by the warranty contained herein.



THE LIMITED WARRANTY DESCRIBED HEREIN IS MADE EXPRESSLY IN LIEU OF ANY OTHER EXPRESSED OR IMPLIED WARRANTIES, INCLUDING ANY IMPLIED WARRANTY OF MERCHANTABILITY OR FITNESS FOR A PARTICULAR PURPOSE. KURT MANUFACTURING COMPANY IS NOT RESPONSIBLE FOR THE IMPROPER USE OF ITS PRODUCTS. KURT SHALL NOT BE LIABLE FOR ANY DIRECT, INDIRECT, INCIDENTAL SPECIAL OR CONSEQUENTIAL DAMAGES, INCLUDING BUT NOT LIMITED TO, LOSS OF USE, REVENUE OR PROFIT.

KURT ASSUMES NO LIABILITY FOR, AND MAKES NO WARRANTY REGARDING ANY PURCHASE ITEMS WHERE THE MANUFACTURER OF SUCH ITEM EXTENDS A SEPARATE WARRANTY.



KURT WORKHOLDING

Thank you for your
purchase! If you have any
feedback or questions
please contact us:

Kurt Industrial Products // A Division Of Kurt Manufacturing

9445 East River Road NW | Mpls, MN 55433
Phone 763-574-8309 | Toll Free 877-226-7823
Fax 763-574-8318 | Toll Free Fax 877-226-7823

kurtworkholding.com | workholding@kurt.com

Manual Revision:
01.08.2025