

KURT MPW420 MANUAL PUSH BUTTON PALLET

Operating Instruction Manual
Model No. MPW420

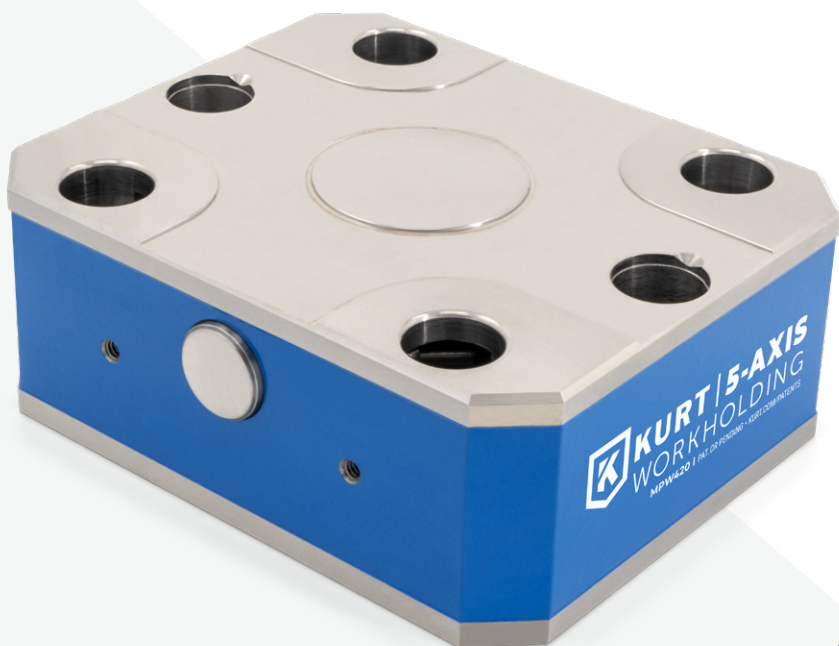

TABLE OF CONTENTS

Introduction 3

Side Dimensions & Set-Up Instructions 4

Top & Bottom Views 5

Maintenance Schedule 6

Warranty 7

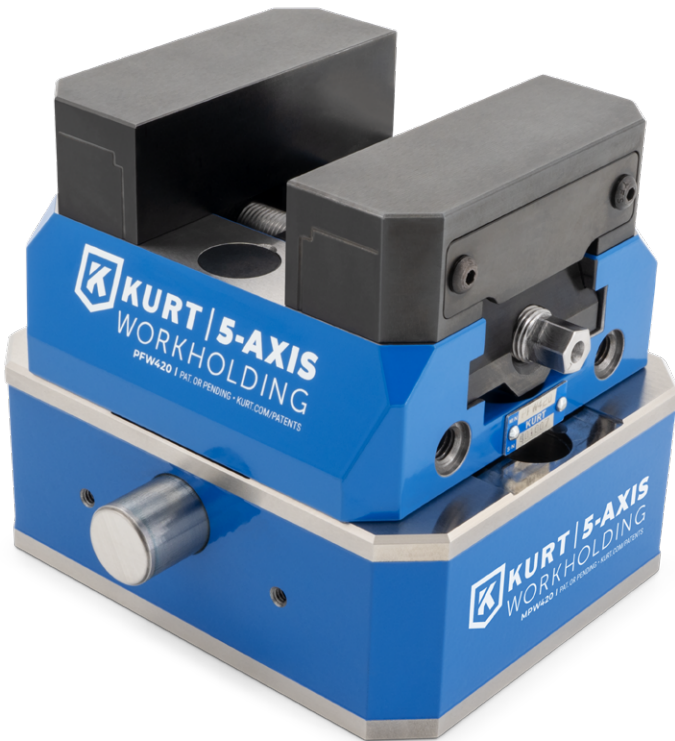

New Kurt PFW420 5-Axis Vise mounted on a MPW420 Manual Pallet

INTRODUCTION

Thank you for purchasing a Kurt 5-Axis vise pallet. This pallet is designed for quick vise changes using 96 mm pull stud spacing and works with Kurt PFW 5-Axis vises or other vises that support 96 mm pull stud mounting patterns.

Included in the box

- Vise Pallet
- 4 pull studs



Fig.1

SIDE DIMENSIONS

Note: Dimensions below are in inches unless specified.

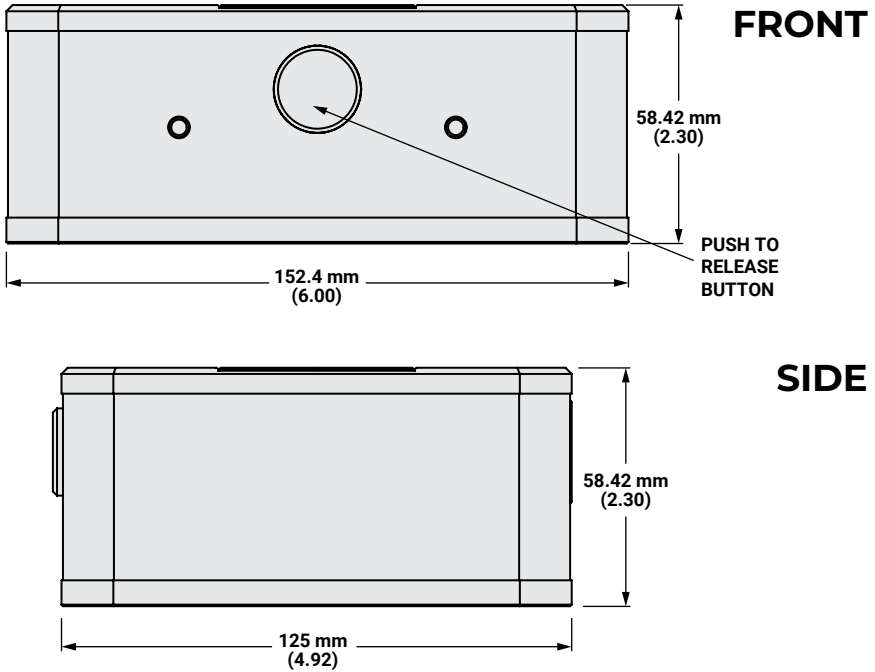

SET-UP INSTRUCTIONS

Pallet precision bores must be protected from chips and coolant. If pallet is not being utilize, leave vise mounted in pallet to cover bores. If this is not an option, utilize stand alone pull down studs to act as a chip guard.

NOTE: NEVER PUT FINGERS OR ANYTHING OTHER THAN PULL STUDS INTO THE PRECISION BORES. INJURY OR DAMAGE COULD RESULT WHEN THE AUTOMATIC CLAMP MECHANISM IS ACTIVATED BY FOREIGN OBJECTS.

Fig.2

TOP & BOTTOM VIEWS

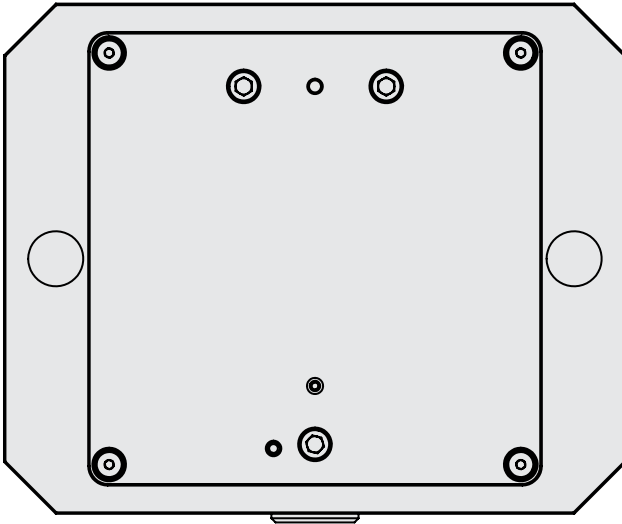
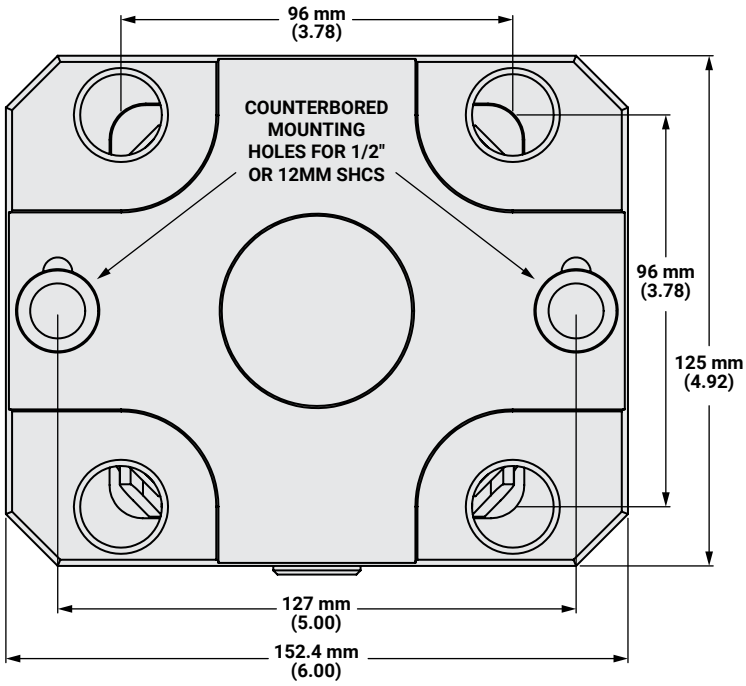

MAINTENANCE SCHEDULE

It is very important to perform regular maintenance on your Kurt pallet to ensure proper operation. Improper maintenance will result in poor performance and pallet operation.

Daily / Weekly

1. Keep surface of pallet clean and free of chips.
2. Visually inspect precision bores for damage.
3. Apply small amount of grease to the pull stud only.

Note: The bottom cover should only be removed by fully trained personnel.

All Kurt Manufacturing Company industrial workholding products and parts with the exceptions noted below, are warranted against defects in material and workmanship for the life of the product or part. (The life of the product is defined as that point in time when such item no longer functions due to normal wear and tear.) Failure to properly maintain and/or properly operate the product or part that has been worn out, abused, heated, ground or otherwise altered, used for a purpose other than that for which it was intended, or used in a manner inconsistent with any instructions regarding its use. The sole obligation of Kurt Manufacturing Company, Inc. (Kurt) and the purchaser's SOLE AND EXCLUSIVE REMEDY hereunder, shall be limited to the replacement or repair of any Kurt product or part (by an authorized Kurt technician) which are returned to Kurt Manufacturing Company's place of business or any authorized service center, transportation, shipping and postal charges prepaid, and there determined by Kurt Manufacturing Company to be covered by the warranty contained herein.



THE LIMITED WARRANTY DESCRIBED HEREIN IS MADE EXPRESSLY IN LIEU OF ANY OTHER EXPRESSED OR IMPLIED WARRANTIES, INCLUDING ANY IMPLIED WARRANTY OF MERCHANTABILITY OR FITNESS FOR A PARTICULAR PURPOSE. KURT MANUFACTURING COMPANY IS NOT RESPONSIBLE FOR THE IMPROPER USE OF ITS PRODUCTS. KURT SHALL NOT BE LIABLE FOR ANY DIRECT, INDIRECT, INCIDENTAL SPECIAL OR CONSEQUENTIAL DAMAGES, INCLUDING BUT NOT LIMITED TO, LOSS OF USE, REVENUE OR PROFIT.

KURT ASSUMES NO LIABILITY FOR, AND MAKES NO WARRANTY REGARDING ANY PURCHASE ITEMS WHERE THE MANUFACTURER OF SUCH ITEM EXTENDS A SEPARATE WARRANTY.

REGISTER YOUR WARRANTY ONLINE AT KURTHOLDING.COM



KURT WORKHOLDING

Thank you for your
purchase! If you have any
feedback or questions
please contact us:

Kurt Industrial Products // A Division Of Kurt Manufacturing

9445 East River Road NW | Mpls, MN 55433
Phone 763-574-8309 | Toll Free 877-226-7823
Fax 763-574-8318 | Toll Free Fax 877-226-7823

kurtworkholding.com | workholding@kurt.com

Manual Revision:
02.27.2025