



KURT 5-AXIS QUICK-CHANGE BASE

125 mm x 125 mm | 52 mm Spacing

Operating Instruction Manual

Model No. 52-A125



ENGLISH

TABLE OF CONTENTS

Introduction 3

Side Dimensions & Set-Up Instructions 4

Top / Bottom Bolt-Hole Safe Zones 5

Optional Indicating Tool 6

Parts List & Mechanical Drawing 7

Maintenance Schedule 8

Warranty 9



New Kurt PFW420 5-Axis Vise mounted on a 52-A125 Quick-Change Base

INTRODUCTION

Thank you for purchasing a Kurt 5-Axis vise pallet. This pallet is designed for quick vise changes using 52 mm pull stud spacing and works with Kurt PFW 5-Axis vises or other vises that support 52 mm pull stud mounting patterns.

Included in the box

- Vise Pallet
- 4 pull studs
- 3/8" hex wrench



Fig.1

SIDE DIMENSIONS

Note: Dimensions below are in inches unless specified.

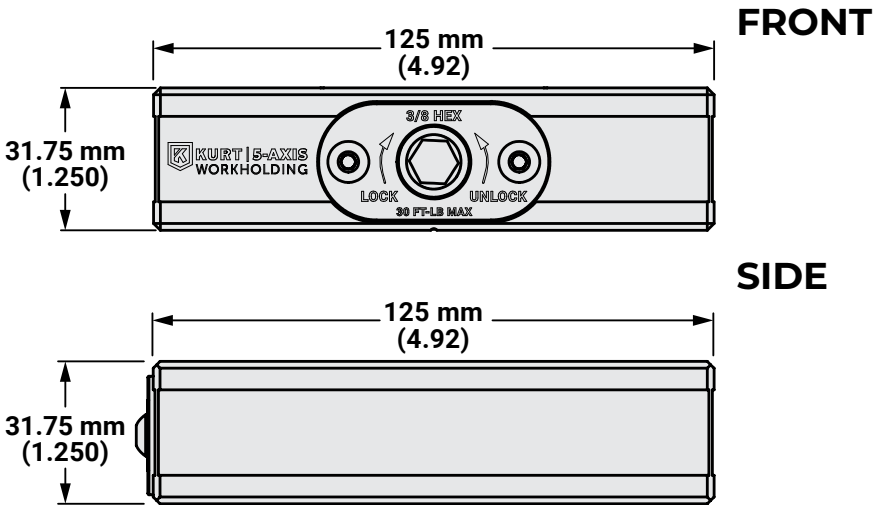

SET-UP INSTRUCTIONS

The Kurt 52 mm quick change base does not ship predrilled for mounting. Refer to machine table requirements for mounting patterns and drill and counterbore holes on Kurt pallet for your own machine application. Mounting hole locations can be machined into the base outside of the yellow areas in Fig.2 on page 5.

Once the base is drilled and counterbored holes have been made, secure the base to the machine table with socket head cap screws.

Pallet precision bores must be protected from chips and coolant. If pallet is not being utilize, leave vise mounted in pallet to cover bores. If this is not an option, utilize stand alone pull down studs to act as a chip guard.

NOTE: WHEN OPERATING PALLET INTO THE FULLY OPEN/ UNLOCKED POSITION (CCW), DO NOT OVER TORQUE THE LEADSCREW AS IT MAY LEAD TO FRONT COVER PLATE DAMAGE. STOP ROTATING LEADSCREW WHEN YOU FEEL IT COME INTO CONTACT WITH ITS INTERNAL STOP.

Fig.2

TOP & BOTTOM VIEWS SAFE BOLT-HOLE ZONES

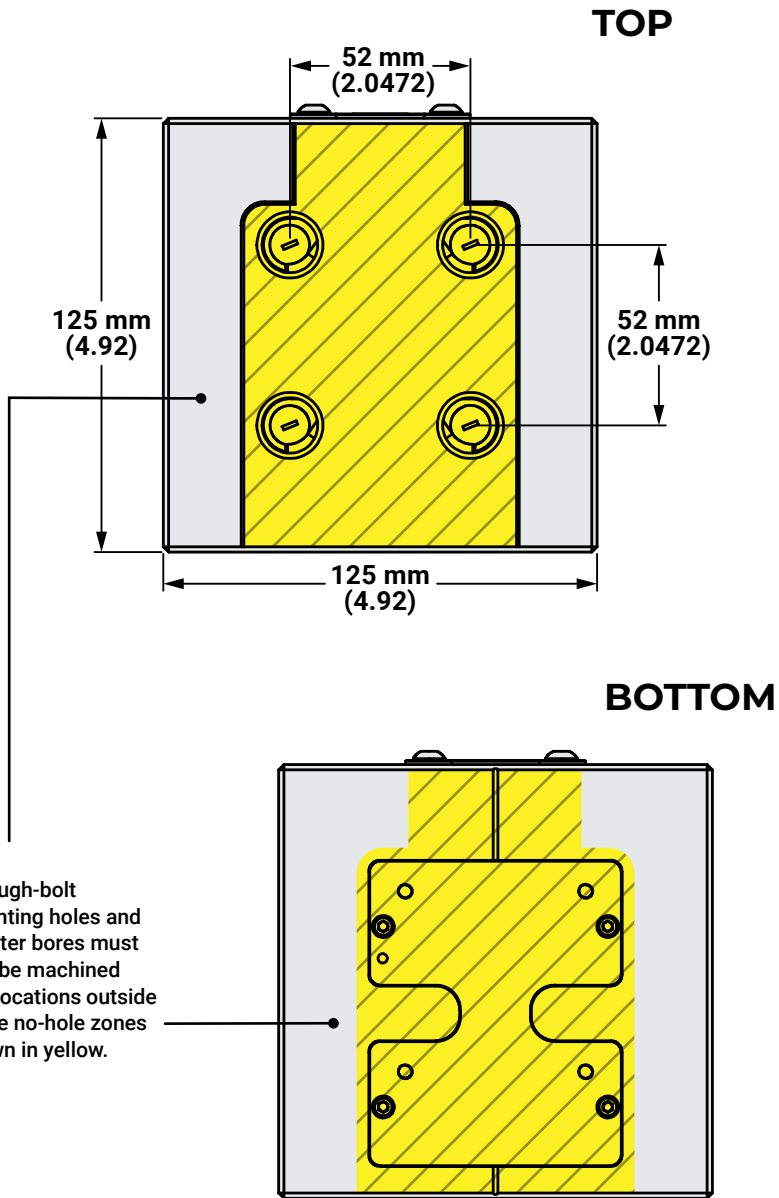

INDICATING TOOL (MASTER PLATE)

To reduce setup time, an optional precision set up tool is available through Kurt.

This tool has the same precision tolerance as the base and body to ensure accurate pallet locating. The pallet has machined scallops to help reach fasteners during setup procedure.

Locate and a pallet:

1. Insert indicating tool into pallet, tighten to a maximum of 30 lb-ft.
2. Using the center bore and/or qualified edges, align the pallet to the center of rotation and/or square to the machine axis. Tighten mounting bolts.
3. Using the marked qualified edges, adjust the pallet to be square to the machine axis.

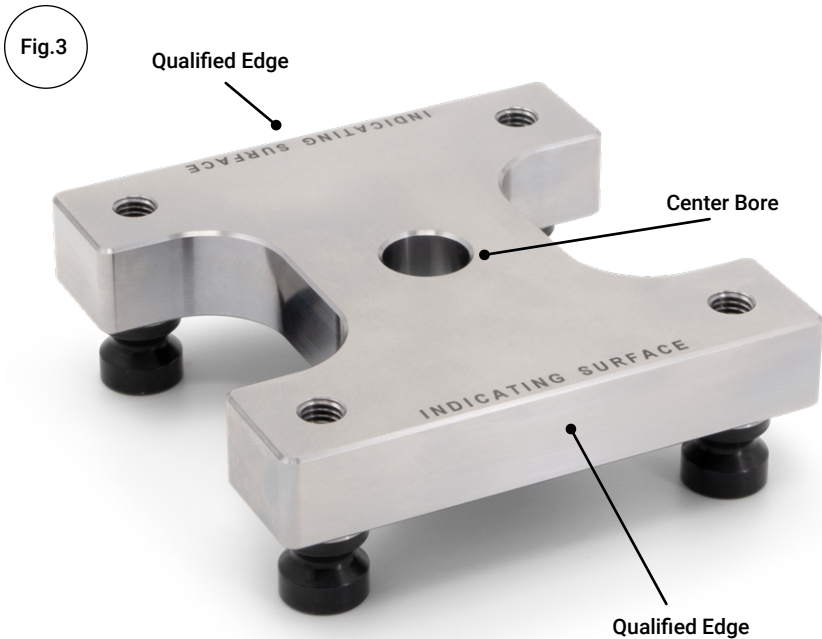

PARTS LIST

ITEM#	PART#	DESCRIPTION	QTY.
1	52-125125	125MM x 125MM BASE	1
2	52-53	BOTTOM COVER	1
3	96-305	O-RING HOLDER	4
4	96-204	THRUST WASHER	1
5	96-118	BOLT COVER	1
6	52-329	UPPER WEDGE	1
7	52-392	LOWER WEDGE	1
8	03-00205	BUTTON HEAD CAP SCREW	2
9	00-1158	BOLT, COVER	4
10	00-0355	SHCS	1
11	40-3201	O-RING	4
12	96-160	BELLEVILLE DISC SPRING	5
13	52-18	LEAD SCREW	1

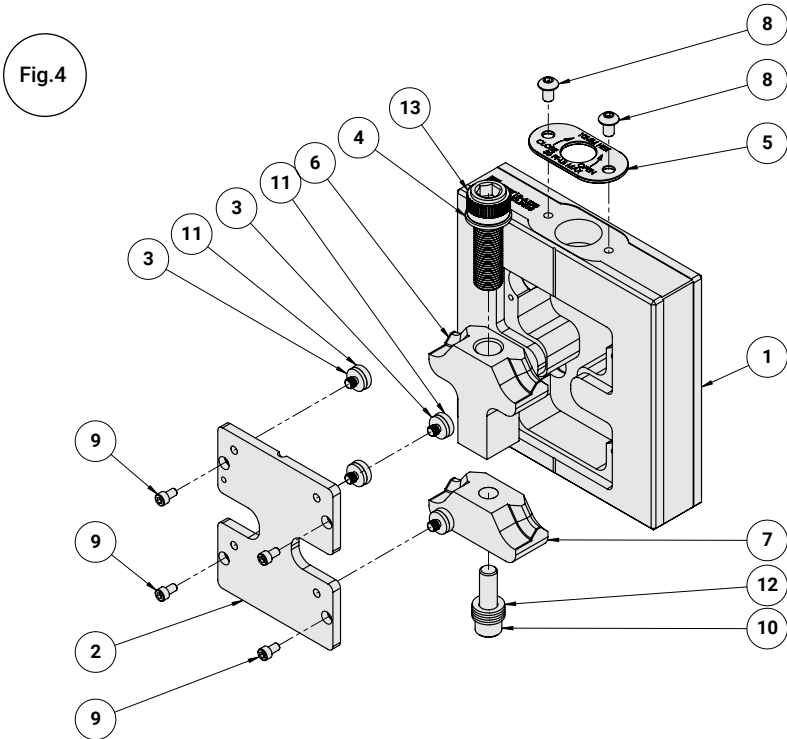

MAINTENANCE SCHEDULE

It is very important to perform regular maintenance on your Kurt pallet to ensure proper operation. Improper maintenance will result in poor performance and pallet operation.

Daily / Weekly

1. Keep surface of pallet clean and free of chips.
2. Visually inspect precision bores for damage.
3. Apply a small dab of high/extreme pressure grease (NLGI #2) to pull down mechanism.

Yearly / Or any time pallet is removed from mounted position

1. Remove bottom cover, clean, dry, and grease internal lead screw and pull down mechanism using high/extreme pressure grease NLGI #2.

All Kurt Manufacturing Company industrial workholding products and parts with the exceptions noted below, are warranted against defects in material and workmanship for the life of the product or part. (The life of the product is defined as that point in time when such item no longer functions due to normal wear and tear.) Failure to properly maintain and/or properly operate the product or part that has been worn out, abused, heated, ground or otherwise altered, used for a purpose other than that for which it was intended, or used in a manner inconsistent with any instructions regarding its use. The sole obligation of Kurt Manufacturing Company, Inc. (Kurt) and the purchaser's SOLE AND EXCLUSIVE REMEDY hereunder, shall be limited to the replacement or repair of any Kurt product or part (by an authorized Kurt technician) which are returned to Kurt Manufacturing Company's place of business or any authorized service center, transportation, shipping and postal charges prepaid, and there determined by Kurt Manufacturing Company to be covered by the warranty contained herein.



THE LIMITED WARRANTY DESCRIBED HEREIN IS MADE EXPRESSLY IN LIEU OF ANY OTHER EXPRESSED OR IMPLIED WARRANTIES, INCLUDING ANY IMPLIED WARRANTY OF MERCHANTABILITY OR FITNESS FOR A PARTICULAR PURPOSE. KURT MANUFACTURING COMPANY IS NOT RESPONSIBLE FOR THE IMPROPER USE OF ITS PRODUCTS. KURT SHALL NOT BE LIABLE FOR ANY DIRECT, INDIRECT, INCIDENTAL SPECIAL OR CONSEQUENTIAL DAMAGES, INCLUDING BUT NOT LIMITED TO, LOSS OF USE, REVENUE OR PROFIT.

KURT ASSUMES NO LIABILITY FOR, AND MAKES NO WARRANTY REGARDING ANY PURCHASE ITEMS WHERE THE MANUFACTURER OF SUCH ITEM EXTENDS A SEPARATE WARRANTY.

REGISTER YOUR WARRANTY ONLINE AT KURTWORKHOLDING.COM



KURT WORKHOLDING

Thank you for your
purchase! If you have any
feedback or questions
please contact us:

Kurt Industrial Products // A Division Of Kurt Manufacturing

9445 East River Road NW | Mpls, MN 55433
Phone 763-574-8309 | Toll Free 877-226-7823
Fax 763-574-8318 | Toll Free Fax 877-226-7823

kurtworkholding.com | workholding@kurt.com

Manual Revision:
02.27.2025